



HP Jet Fusion 5200, 5210, 5210 Pro 3D Printing Solution

Product Documentation
User Guide

© Copyright 2019 HP Development Company, L.P.

Edition 1

Legal notices

The information contained herein is subject to change without notice.

The only warranties for HP products and services are set forth in the express warranty statement accompanying such products and services. Nothing herein should be construed as constituting an additional warranty. HP shall not be liable for technical or editorial errors or omissions contained herein.

Safety notice

Read and follow the operating and safety instructions before turning on the equipment.

Trademarks

Intel® and Intel Core™ are trademarks of Intel Corporation in the U.S. and other countries.

Microsoft® and Windows® are U.S. registered trademarks of Microsoft Corporation.

All products and company names are registered trademarks of their original owners. The use of any trademark is for identification and reference purposes only and does not imply any association between HP and the trademark owner or product brand.

Table of contents

1 Welcome to your MJF system	1
Documentation	2
Product usage requirements	2
MJF technology	2
Usage recommendations	4
2 Safety precautions	5
Introduction	6
General safety guidelines	6
Final parts/builds	7
Explosion hazard	7
Electrical shock hazard	8
Heat hazard	9
Fire hazard	9
Mechanical hazard	10
Light radiation hazard	10
Chemical hazard	10
Ventilation	10
Air conditioning	10
Extraction system	11
Sound pressure level	11
Build unit transport hazard	11
3D part unpacking	12
Personal protective equipment	12
Use of tools	12
Warnings and cautions	12
Warning labels	13
Emergency stop buttons	16
3 Main components	17
Printer	18
Processing station	20
Build unit	21
Accessories	22

Front panel	22
Software	26
4 Power on and off	32
Turn the printer on and off	33
Turn the processing station on and off	34
Circuit-breaker labels	35
5 Printer and processing station networking	36
Connectivity and remote monitoring requirements	36
Configuration	37
Troubleshooting	38
6 Consumables	39
Printer	40
Processing station	56
How to recycle supplies	68
7 Design and printing guidelines	69
Introduction	70
File preparation	70
Minimum specification for parts	74
8 Load material into the build unit	89
Loading procedure	90
Change to a different type of material	93
9 Print	104
Job list app	105
Send a job to be printed	105
Select a job to be printed	105
Add job while printing (5210 only)	105
Cancel a job	106
Check status on the front panel	107
Check status remotely	107
Possible errors while printing	107
Print modes	108
10 Unpack the build	109
11 Part cleaning and postprocessing	118

12 Hardware maintenance	119
Safety precautions	120
Maintenance resources	120
Printer maintenance	126
Processing-station maintenance	203
Build-unit maintenance	221
Move or store the product	227
13 Print-quality optimization	229
General advice	230
Printhead health troubleshooting	230
Recover (clean) the printheads	245
Airflow check	246
14 Ordering information	255
15 System errors	256
Introduction	257
0051-0008-0001 Mixer loading nozzle sensor PCA malfunction	257
0085-0008-0X94 Carriage – Printhead – Temperature extremely high	257
0085-0008-0X86 Carriage – Printhead – Temperature too high	258
0085-0008-0X95 Carriage – Printhead – Temperature extremely low	258
0085-0008-0X87 Carriage – Printhead – Temperature too low	258
0085-0008-0X82 Carriage – Printhead – Data not responding	258
0085-0008-0X98 Carriage – Printhead – Transmit error	259
0085-0008-0X96 Carriage – Printhead – Energy calibration failure	259
0085-0008-0X93 Carriage – Printhead – Fails continuity	259
0085-0008-0X85 Carriage – Printhead – Fails logical	259
0085-0008-0X10 Carriage – Printhead – Voltage out of range	259
0085-0013-0X01 Carriage – Primer – Malfunction	260
0085-0013-0X33 Carriage – Primer – Current too high	260
0085-0013-0X41 Carriage – Primer – Leakage	260
809C-D706-0000	261
16 When you need help	262
Request support	262
Customer Self-Repair	262
Service information	262
17 Accessibility	263
Front panel	263

1 Welcome to your MJF system

- [Documentation](#)
- [Product usage requirements](#)
- [MJF technology](#)
- [Usage recommendations](#)

Documentation

The following documents are available:

- Site preparation guide
- Introduction information
- User guide (this document)
- Videos supplementing the user guide
- Legal information
- Limited warranty
- HP SmartStream 3D Build Manager User Guide

These documents can be downloaded from the appropriate webpage:

- <http://www.hp.com/go/jetfusion3D5200/manuals>
- <http://www.hp.com/go/jetfusion3D5210/manuals>
- <http://www.hp.com/go/jetfusion3D5210pro/manuals>

Product usage requirements

The products, services, and consumables are subject to the following additional terms:

- The customer agrees to use only HP Branded Consumables and HP Certified Materials in the 3D HP printer product, and understands that use of any consumables other than HP consumables may cause serious product functionality and/or safety issues, including, but not limited to those outlined in the user guide. The customer agrees not to use the product and/or consumables for uses not permitted by US, EU, and/or other applicable law.
- The customer agrees not to use the product and/or consumables for the development, design, manufacture, or production of nuclear weapons, missiles, chemical or biological weapons, and/or explosives of any kind.
- The customer agrees to comply with the connectivity requirement outlined below.
- The customer may use firmware embedded in the product only to enable the product to function in accordance with its published specifications.
- The customer agrees to comply with the user guide.
- Products, services, and/or technical data provided under these terms are for the customer's internal use and not intended for further resale.

MJF technology

HP Multi Jet Fusion technology offers speed advantages and control over part and material properties beyond those found in other 3D printing processes.

HP Multi Jet Fusion technology starts by laying down a thin layer of material in the working area. Next, the carriage containing an HP Thermal Inkjet array passes from left to right, printing chemical agents across the full working area. The layering and energy processes are combined in a continuous pass of the second carriage from top to bottom. The process continues, layer-by-layer, until a complete part is formed. At each layer, the carriages change direction for optimum productivity.

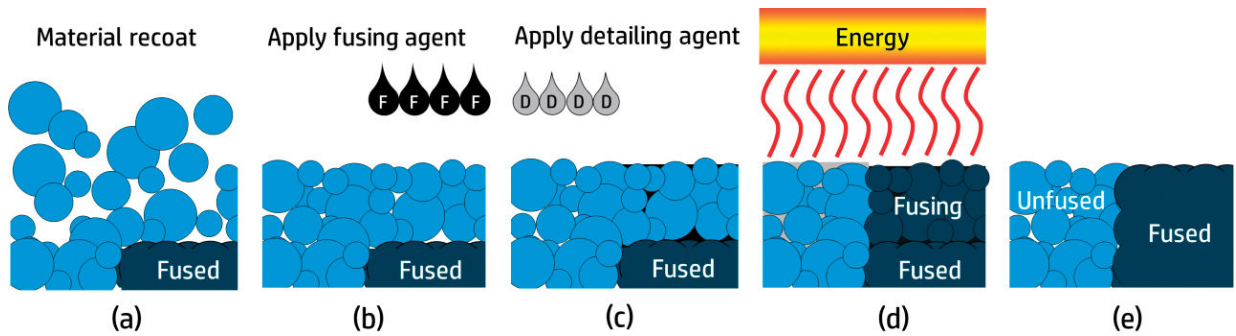

- a. The material is recoated across the work area.
- b. A fusing agent (F) is selectively applied where the particles are to fuse together.
- c. A detailing agent (D) is selectively applied where the fusing action needs to be reduced or amplified. In this example, the detailing agent reduces fusing at the boundary to produce a part with sharp and smooth edges.
- d. The work area is exposed to fusing energy.
- e. The part now consists of fused and unfused areas.

The process is repeated until the complete part has been formed.

 **NOTE:** The sequence of steps above is typical, but may be changed in specific hardware implementations.

HP Multi Jet Fusion technology can realize the full potential of 3D printing through the production of highly functional parts. Using HP Thermal Inkjet arrays, HP Multi Jet Fusion technology is built on HP's technical core competency of rapidly and accurately placing precise (and minute) quantities of multiple types of fluids. This gives HP Multi Jet Fusion technology a versatility and potential not found in other 3D printing technologies.

In addition to fusing and detailing agents, HP Multi Jet Fusion technology can employ additional agents to transform properties at each volumetric pixel (or voxel). These agents, transforming agents, deposited point-by-point across each cross-section, allow HP Multi Jet Fusion technology to produce parts that cannot be made by other methods.

For example, taking advantage of HP's in-depth knowledge of color science, HP Multi Jet Fusion printers could selectively print a different color at each voxel with agents containing cyan, magenta, yellow, or black (CMYK) colorants.

The long-term vision for HP Multi Jet Fusion technology is to create parts with controllably variable—even quite different—mechanical and physical properties within a single part or among separate parts processed simultaneously in the working area. This is accomplished by controlling the interaction of the fusing and detailing agents with each other, with the material to be fused, and with additional transforming agents.

HP Multi Jet Fusion technology can provide design and manufacturing possibilities that surpass the limits of our imagination. That's what technological breakthroughs do.

Usage recommendations

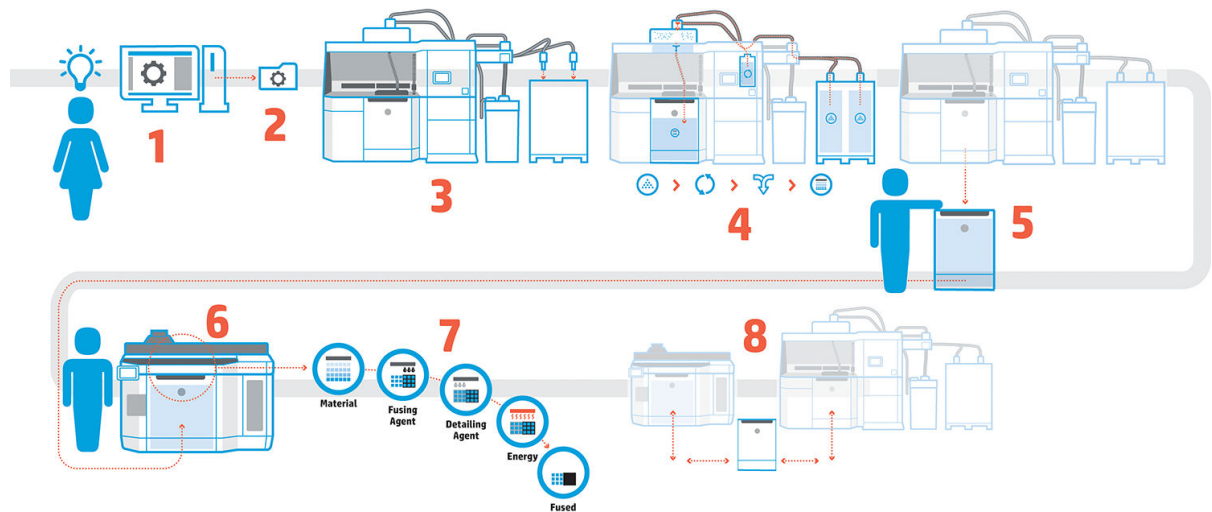

1. **Prepare your design for printing:** Open your 3D model and check for errors with easy-to-use HP software.
2. **Pack models and send to printer:** Place multiple models into the software and submit the job to the printer.
3. **Add materials:** Insert the material cartridges into the processing station.
4. **Automated mixing:** You will have a clean loading and mixing experience because the processing station is enclosed and automated. Materials are loaded into the build unit.
5. **Remove the build unit from the processing station.**
6. **Slide the build unit into the printer.**
7. **Printing with voxel-level control:** Just tap **Start** to get extreme dimensional accuracy and fine detail, thanks to HP's unique multi-agent printing process.
8. **Streamlined workflow:** The build unit can be removed from the printer—which is now ready for the next build—and slid back into the processing station.

2 Safety precautions

- [Introduction](#)
- [General safety guidelines](#)
- [Final parts/builds](#)
- [Explosion hazard](#)
- [Electrical shock hazard](#)
- [Heat hazard](#)
- [Fire hazard](#)
- [Mechanical hazard](#)
- [Light radiation hazard](#)
- [Chemical hazard](#)
- [Ventilation](#)
- [Air conditioning](#)
- [Extraction system](#)
- [Sound pressure level](#)
- [Build unit transport hazard](#)
- [3D part unpacking](#)
- [Personal protective equipment](#)
- [Use of tools](#)
- [Warnings and cautions](#)
- [Warning labels](#)
- [Emergency stop buttons](#)

Introduction

Before using the equipment, read the following safety precautions and operating instructions to make sure you can use it safely.

You are expected to have the appropriate technical training and experience necessary to be aware of hazards to which you may be exposed in performing a task, and to take appropriate measures to minimize the risks to yourself and to others.

Perform the recommended maintenance and cleaning tasks to ensure the correct and safe operation of the equipment.

Operations must be supervised at all times.

The equipment is stationary, and should be located in a restricted-access area, for authorized personnel only.

General safety guidelines

Turn off all equipment, using the branch circuit breakers located in the building's Power Distribution Unit (PDU), and call your service representative (see [When you need help on page 262](#)) in any of the following cases:

- The power cord is damaged.
- The top heating and fusing lamp enclosures are damaged, the glass is missing or broken, or the sealing is defective.
- The equipment has been damaged by an impact.
- Liquid has entered the equipment.
- There is smoke or an unusual smell coming from the equipment.
- The built-in Residual Current Circuit Breaker (Ground Fault Circuit Interrupter) has been repeatedly tripped.
- Fuses have blown.
- The equipment is not operating normally.
- There is any mechanical or enclosure damage.

Turn off the equipment using the branch circuit breakers in either of the following cases:

- During a thunderstorm
- During a power failure

Operate the equipment only within the specified ranges of operating temperature and humidity. See the site preparation guide, which can be downloaded from:

- <http://www.hp.com/go/jetfusion3D5200/manuals>
- <http://www.hp.com/go/jetfusion3D5210/manuals>
- <http://www.hp.com/go/jetfusion3D5210pro/manuals>

The printer, build unit, and processing station should always be kept in the same environmental conditions.

The print-production area in which the equipment is installed should be free from liquid spillage and environmental condensation.

Ensure that there is no condensation inside the equipment before turning it on.

Take special care with zones marked with warning labels.

Use HP-certified and HP-branded material and agents only. Do not use unauthorized third-party material or agents.

Use HP-certified external tanks only. The use of third-party external tanks can cause safety risks, material leakages, and malfunctions in the processing station; and may affect your system warranty.

In case of unexpected malfunction, anomaly, ESD (ElectroStatic Discharges), or electromagnetic interference, press the emergency stop button and disconnect the equipment. If the problem persists, contact your support representative.

Final parts/builds

The customer assumes all risk relating to or arising from the 3D printed parts.

The customer is solely responsible for the evaluation of and determination of the suitability and compliance with applicable regulations of the products and/or 3D printed parts for any use, especially for uses (including but not limited to medical/dental, food contact, automotive, heavy industry, and consumer products) that are regulated by US, EU, and other applicable governments.

Explosion hazard

 **WARNING!** Dust clouds can form explosive mixtures with air. Take precautionary measures against static charges, and keep away from sources of ignition.

NOTICE: The equipment is not intended for hazardous locations or ATEX classified zones: ordinary locations only.

To avoid the risk of explosion, take the following precautions:

- Smoking, candles, welding, and open flames should be forbidden close to the equipment or material storage area.
- Inside and outside the equipment should be cleaned regularly with an explosion-protected vacuum cleaner to avoid dust accumulation. Do not sweep the dust or try to remove it with a compressed-air gun.
- An explosion-protected vacuum cleaner certified for collection of combustible dust is required for cleaning. Take measures to mitigate material spillage and avoid potential ignition sources such as ESD (ElectroStatic Discharges), flames, and sparks. Do not smoke nearby.
- The equipment and accessories must be properly grounded at mains outlets only; do not manipulate internal bonding. If static discharges or electrical sparks are noticed, stop operation, disconnect the equipment, and contact your support representative.
- Check the air filters and the sealing of the heating lamps regularly, as specified in [Hardware maintenance on page 119](#). Do not remove filters or lamp glasses.
- Use HP-certified and HP-branded material and agents only. Do not use unauthorized third-party material or third-party agents.
- HP recommends the use of HP accessories for unpacking 3D parts and refilling the build chamber. If other methods are used, read the following notes:
 - Dust clouds generated during handling and/or storage can form explosive mixtures with air. Dust explosion characteristics vary with the particle size, particle shape, moisture content, contaminants, and other variables.
 - Check that all equipment is properly grounded and installed to satisfy electrical classification requirements. As with any dry material, pouring this material or allowing it to fall freely or be conveyed through chutes or pipes can accumulate and generate electrostatic sparks, potentially

causing ignition of the material itself, or of any flammable materials which may come into contact with the material or its container.

- Material storage, handling, and disposal as per local laws. See the Safety Data Sheets at <http://www.hp.com/go/msds> for adequate handling and storage. Follow your Environmental, Health, and Safety processes and procedures.
- Do not place the equipment in a hazardous location area, keep separated from other equipment that could create a combustible dust cloud during its operation.
- Auxiliary post-processing equipment, as sand blasting, must be suitable for combustible dust.
- Stop operation immediately if sparks or material spillages are seen, and call your HP service representative before continuing.
- All personnel, when handling combustible dust, should be freed from static electricity by using conductive or dissipative footwear and clothing, and a conductive floor.

Additionally, for the 5210 Pro processing station only:

- Use a bulk discharging system and drum rotator suitable for combustible dust and compatible with the material that you intend to use.
- Keep an area of at least 2 m (79 in) around the bulk discharging system clear of electric/electronic devices and any sources of ignition.
- Use rigid pipes and flexible hoses suitable for transporting combustible powder and properly earthed.
- Use static earthing clamps to connect a material loading tank when used as bulk material supply.

Electrical shock hazard

 **WARNING!** The internal circuits inside the e-cabinet, top heating, fusing lamps, build unit, and processing station operate at hazardous voltages capable of causing death or serious personal injury.

Turn off the equipment using the branch circuit breakers located in the building's Power Distribution Unit (PDU) before servicing. The equipment must be connected to earth at mains outlets only.

To avoid the risk of electric shock:

- Do not attempt to dismantle the internal circuit enclosures, top heating, fusing lamps, build unit, processing station, or e-cabinet except during hardware maintenance tasks. In that case, follow the instructions strictly.
- Do not remove or open any other closed system covers or plugs.
- Do not insert objects through slots in the equipment.
- Test the functionality of the Residual Current Circuit Breakers (RCCBs) every year. See [Check the functionality of the Residual Current Circuit Breakers \(RCCBs\) on page 202](#) and [Check the functionality of the Residual Current Circuit Breaker \(RCCB\) on page 213](#).

 **NOTE:** A blown fuse may indicate malfunctioning electrical circuits within the system. Call your service representative (see [When you need help on page 262](#)), and do not attempt to replace the fuse yourself.

Heat hazard

The top heating, fusing, and build chamber subsystems of the printer operate at high temperatures and can cause burns if touched. To avoid personal injury, take the following precautions:

- Take special care when accessing the printing area. Let the printer cool down before you open the covers.
- Take special care with zones marked with warning labels.
- Do not place objects inside the equipment while operating.
- Do not cover enclosures while operating.
- Remember to let the equipment cool down before performing some maintenance operations.
- Wait for at least the minimum cooling time (see [Unpack the build on page 109](#)) before extracting the build unit from the printer after printing, or unpacking parts from the build unit.

Fire hazard

The top heating, fusing, and build chamber subsystems of the printer operate at high temperatures. Call your service representative if the built-in Residual Current Circuit Breaker (Ground Fault Circuit Interrupter) is repeatedly tripped.

To avoid the risk of fire, take the following precautions:

- Use the power supply voltage specified on the nameplate.
- Connect the power cord to a dedicated line, protected by a branch circuit breaker according to the information detailed in the site preparation guide.
- Do not insert objects through slots in the equipment.
- Take care not to spill liquid on the equipment. After cleaning, make sure all components are dry before using the equipment again.
- Do not use aerosol products that contain flammable gases inside or around the equipment. Do not operate the equipment in an explosive atmosphere.
- Do not block or cover the openings of the equipment.
- Do not attempt to modify the top heating, fusing, build chamber, e-cabinet, or enclosures.
- Proper maintenance and genuine HP consumables are required to ensure that the equipment operates safely as designed. The use of non-HP consumables may present a risk of fire.
- Take special care with zones marked with warning labels.
- Do not place objects covering top cover, enclosures, or air ventilation.
- Do not leave tools or other materials inside equipment after maintenance or servicing.

Suitable materials for fire-fighting include carbon dioxide, water spray, dry chemicals, or foam.

 **CAUTION:** Do not use a jet of water, as it could scatter and spread the fire.

 **WARNING!** Depending on the material used, some unhealthy substances can be released into the air in case of incidental fire. Wear self-contained pressure-demand breathing apparatus and full protective gear. Your EHS specialist should consult the Safety Data Sheet (SDS) about each material, available at <http://www.hp.com/go/msds>, and advice on the appropriate measures for your location.

Mechanical hazard

The equipment has moving parts that could cause injury. To avoid personal injury, take the following precautions when working close to the equipment.

- Keep your clothing and all parts of your body away from moving parts.
- Avoid wearing necklaces, bracelets, and other hanging objects.
- If your hair is long, try to secure it so that it will not fall into the equipment.
- Take care that sleeves or gloves do not get caught in moving parts.
- Avoid standing close to the fans, which could cause injury and could also affect print quality (by obstructing the air flow).
- Do not operate the equipment with covers bypassed.

Light radiation hazard

Infrared (IR) radiation is emitted from the top heating and fusing lamps. The enclosures limit radiation in compliance with the requirements of the exempt group of IEC 62471:2006, *Photobiological safety of lamps and lamp systems*. Do not modify the top cover enclosure, nor the glasses or windows.

Chemical hazard

See the Safety Data Sheets available at <http://www.hp.com/go/msds> to identify the chemical ingredients of your consumables (material and agents). Sufficient ventilation needs to be provided to ensure that potential airborne exposure to these substances is adequately controlled. Consult your usual air conditioning or EHS specialist for advice on the appropriate measures for your location.

Use HP-certified material and agents only. Do not use unauthorized third-party material or third-party agents.

 **WARNING!** Hazardous substances could be released when processing material. To avoid this risk, install an extraction system (see the site preparation guide).

Ventilation

Fresh air ventilation is needed to maintain comfort levels. For a more prescriptive approach to adequate ventilation, you could refer to the latest edition of the ANSI/ASHRAE (American Society of Heating, Refrigerating and Air-Conditioning Engineers) document *Ventilation for Acceptable Indoor Air Quality*.

Adequate ventilation needs to be provided to ensure that potential airborne exposure to materials and agents is adequately controlled according to their Safety Data Sheets.

Ventilation should meet local environmental, health, and safety (EHS) guidelines and regulations.

For the printer and processing station, follow the ventilation recommendations in the site preparation guide.

 **NOTE:** The ventilation units should not blow air directly onto the equipment.

Air conditioning

Air conditioning in the work area should take into account that the equipment produces heat. For more information, see the air-conditioning section in the site preparation guide.

Air conditioning should meet local environmental, health, and safety (EHS) guidelines and regulations.



NOTE: The air conditioning units should not blow air directly onto the equipment.

Extraction system

The printer has been designed to be able to work either exhausting air into the room or connected to an extraction system installed by the customer. There are various advantages of the latter: first, it's a way to decrease the printer's heat output into the room, so room temperature will be reduced. Additionally, with the extraction, room air ventilation requirements are lower, the presence of airborne materials is reduced, and the level of noise is lower. Therefore, HP highly recommends connecting the printer to an extraction system, and this may be obligatory depending on the material processed and local regulations.

To install an extraction system that meets the printer's requirements, follow the extraction system recommendations in the site preparation guide. As ventilation and air conditioning are related to the extraction system, you should also follow the ventilation and air-conditioning recommendations in the site preparation guide.

In general, you should not need to adjust the extraction system after installation. However, if too much or too little aspiration occurs, system errors will be reported and some readjustment may be required. For that purpose, a maintenance procedure is provided to assist you.

Sound pressure level

Printer and build unit

Declared dual number noise emission values in accordance with ISO 4871, corresponding to the worst bystander position according to ISO 11202, located at the rear of the printer:

- LpA = 75 dB(A), measured with the fans turning at maximum speed
- KpA = 5 dB

Processing station and build unit

Declared dual number noise emission values in accordance with ISO 4871, corresponding to the microphone position located in the dedicated operator area in accordance with ISO 11202:

- LpA = 73 dB(A), measured during the unpacking process
- KpA = 5 dB

Hearing protection may be required as per local laws; consult your EHS specialist.

Build unit transport hazard

Special care must be taken to avoid personal injury when moving the build unit.

- Always wear personal protective equipment including boots and gloves.
- Keep the safety lid on top of the build unit at all times, except when it is inside the printer or processing station.
- Steer the build unit using the handle only.
- Move the build unit over smooth, flat surfaces without steps.
- Move with care and avoid shocks during transport, which could spill the material.
- Lock the front casters when not moving the build unit. Remember to unlock them before moving it.

If moving the build unit between different rooms, bear in mind that it should be kept in constant environmental conditions.

3D part unpacking

Wear heat-resistant gloves when unpacking 3D printed parts.

Personal protective equipment

Heat-resistant gloves, masks, goggles, conductive or dissipative footwear, conductive or dissipative clothing, and hearing protection are recommended for certain maintenance tasks and material handling.

Use of tools

- **Users:** Daily operations including printer settings, printing, unpacking and refilling, replacement of agent reservoirs, and daily checks. No tool is required.
- **Maintenance personnel:** Hardware maintenance tasks and replacement of Customer Self-Replaceable (CSR) parts may require a screwdriver, as described in [Hardware maintenance on page 119](#).

 **WARNING!** Use appropriate tools (anti-spark, for example) in hazardous locations or ATEX classified zones.

 **NOTE:** During installation, the designated personnel receive training for the safe operation and maintenance of the equipment. The equipment should not be used without this training.





Warnings and cautions





The following symbols are used in this manual to ensure the proper use of the equipment and to prevent it from being damaged. Follow the instructions marked with these symbols.





 **WARNING!** Failure to follow the guidelines marked with this symbol could result in serious personal injury or death.

 **CAUTION:** Failure to follow the guidelines marked with this symbol could result in minor personal injury or damage to the product.

Warning labels

Label	Explanation
 <p>ELECTRIC SHOCK HAZARD Heating modules operate at hazardous voltages. Disconnect all power sources before servicing. Caution! Double pole. Neutral fusing.</p> <p>WARNING High leakage current. Earth connection essential before connecting supply. Before connecting Power Supply cord to the unit, refer to the Installation Instructions to determine proper input voltage configuration.</p> <p>Before starting, read and follow the operating and safety instructions. Avant de commencer, lisez et suivez les instructions de fonctionnement et de sécurité. Lesen und befolgen Sie bitte die Bedienungs- und Sicherheitsanweisungen, bevor Sie starten. Antes de empezar, lea y siga las instrucciones sobre funcionamiento y seguridad. 开始之前，请阅读并遵循以下操作和安全说明。 在開始之前，請先閱讀並依照操作與安全指引進行。</p>	<p>Electric shock hazard</p> <p>Heating modules operate at hazardous voltage. Disconnect power source before servicing.</p> <p>CAUTION: Double pole. Neutral fusing. Refer servicing to qualified service personnel.</p> <p>In case of operation of the fuse, parts of the equipment that remain energized may represent a hazard during servicing. Before servicing, turn off the equipment using the Branch Circuit Breakers located in the building's Power Distribution Unit (PDU).</p> <p>WARNING! High leakage current. Current leakage may exceed 3.5 mA. Earth connection essential before connecting supply. Equipment to be connected to earthed mains only.</p> <p>See installation instructions before connecting to the supply. Ensure that the input voltage is within the equipment's rated voltage range.</p> <p>Before starting</p> <p>Read and follow the operating and safety instructions before starting the equipment.</p>
<p>For service personnel only</p>	
	<p>Risk of burns. Let the equipment cool down before accessing internal parts.</p>
	<p>You are recommended to wear gloves when handling material cartridges, agents, printheads, the printhead cleaning roll, and when performing maintenance cleaning tasks.</p> <p>You are recommended to wear heat-resistant gloves when unpacking parts in the processing station. The temperature can be higher than 80°C (176°F).</p>
	<p>You are recommended to wear a safety mask when replacing filters.</p>
	<p>You are recommended to wear safety goggles when replacing filters.</p>

Label	Explanation
	Do not step over the support platform of the material cartridges.
	Do not climb onto the external tank, which could cause the processing station to fall over.
	Crush hazard. Keep your hands clear of the edge of the top cover. Open and close the top cover using the handle (highlighted in blue) only.
	<p>WARNING! Dust clouds can form explosive mixtures with air. Take precautionary measures against static charges, and keep away from sources of ignition.</p> <p>No smoking, matches, or open flames close to equipment or material storage area.</p>
	<p>An explosion-protected vacuum cleaner certified for collection of combustible dust is required for cleaning.</p> <p>Take measures to mitigate material spillage and avoid potential ignition sources such as ESD (ElectroStatic Discharges), flames, and sparks. Do not smoke nearby.</p> <p>Disposal as per local laws.</p>
	Electric shock hazard. Disconnect power before servicing. Heating modules and electrical cabinets operate at hazardous voltage.
For maintenance and service personnel only	
	Hazardous moving parts. Keep away from moving fan blades.
For maintenance and service personnel only	

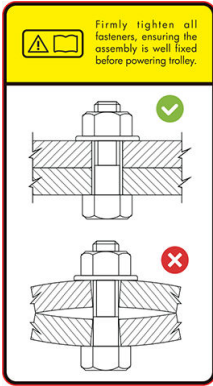
Label	Explanation
 <p data-bbox="277 459 655 483">For maintenance and service personnel only</p>	<p data-bbox="879 226 1414 277">Risk of trapped fingers. Do not touch gears while moving: your hands may be trapped between the gearwheels.</p>
 <p data-bbox="277 741 504 766">For service personnel only</p>	<p data-bbox="879 510 1453 584">Hazardous moving part. Keep away from the moving print carriage and cable/hose carriers. When printing, the print carriage travels back and forth.</p>
	<p data-bbox="879 792 1465 866">Identifies the Protective Earth (PE) terminal for qualified electricians, and bonding terminals for maintenance/service personnel only. An earth connection is essential before connecting to the supply.</p>
	<p data-bbox="879 1016 1362 1041">Do not disconnect the hoses during the purging process.</p>
	<p data-bbox="879 1240 1461 1292">Firmly tighten all fasteners, ensuring that the assembly is well fixed together before turning on the build unit.</p>

Emergency stop buttons

There is an emergency stop button on the printer and another on the processing station. If an emergency occurs, simply push the emergency stop button to stop all processes.

- In the case of the printer, the printer carriage, the recoater, the lamps, and the build unit are halted; the build-unit door and top cover are locked until the internal temperature decreases.
- In the case of the processing station, the vacuum system, the motors, and the build unit are halted.

A system error message is displayed, and the fans turn at maximum speed. Ensure that the emergency stop button is released before restarting the equipment.

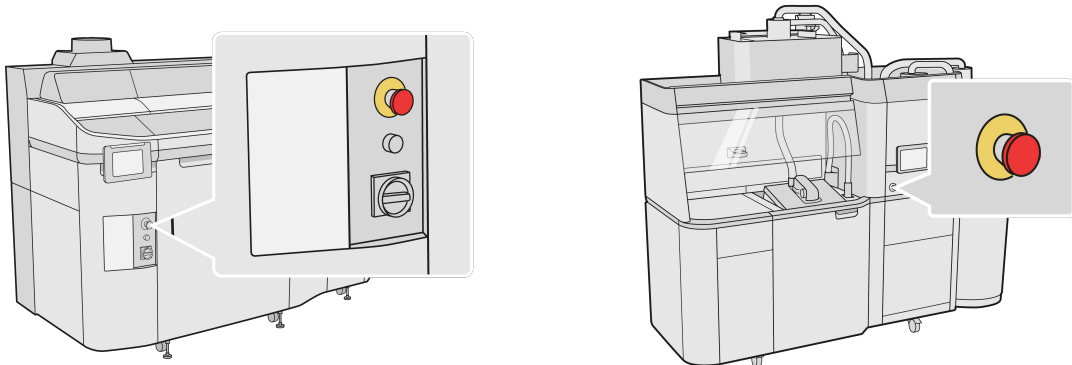

For safety reasons, access to the print zone is not permitted while printing is in progress. Let the printer cool down before touching anything inside it.

To stop the equipment completely, turn it off. See [Turn the printer on and off on page 33](#) and [Turn the processing station on and off on page 34](#).

3 Main components

- [Printer](#)
- [Processing station](#)
- [Build unit](#)
- [Accessories](#)
- [Front panel](#)
- [Software](#)

Printer

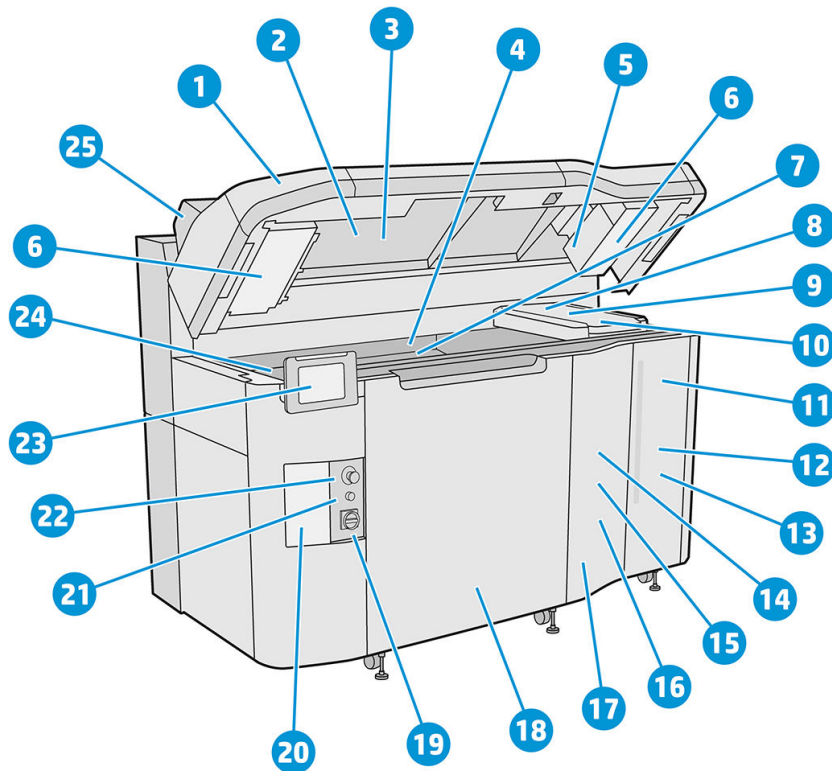

1. Top cover
2. Heating lamps
3. Thermal camera
4. Recoating unit and recoating roller
5. Heating-lamps filter
6. Top-enclosure filters
7. Print bed
8. Printhead
9. Fusing lamps
10. Print carriage
11. Fusing agent
12. Agent door
13. Detailing agent
14. Printhead cleaning roll
15. Internal cleaning-roll door
16. Cleaning-roll collector
17. External cleaning-roll door
18. Build-unit door
19. Main switch

- 20. Circuit breaker
- 21. Rearm button
- 22. Emergency stop button
- 23. Front panel
- 24. Spittoon
- 25. Air exhaust

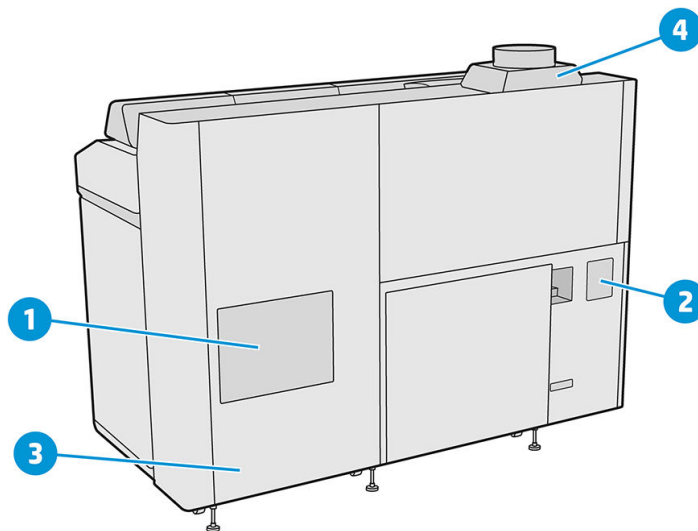

- 1. Print-zone filter
- 2. E-cabinet filter
- 3. Network and electrical connections
- 4. Air exhaust system

Processing station

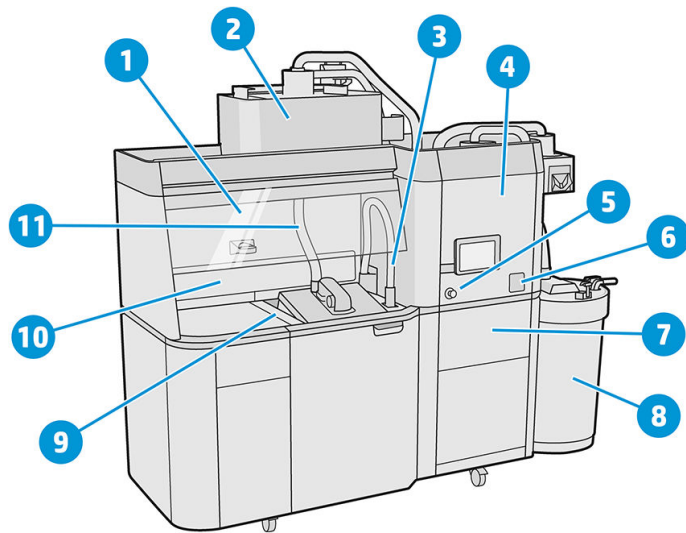

1. Hood
2. Mixer
3. Reusable material collector
4. Storage tank
5. Emergency stop button
6. Service switch
7. Sieve
8. External tank
9. Platform control buttons
10. Dust extractor
11. Material loading nozzle

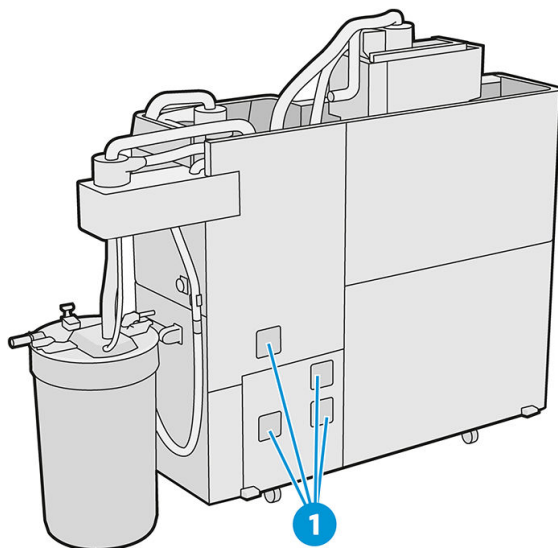

1. E-cabinet filters

Build unit

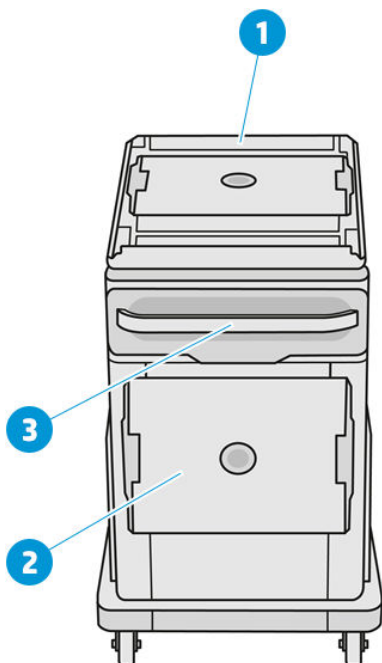

1. Material loading inlet
2. Safety lid
3. Handle

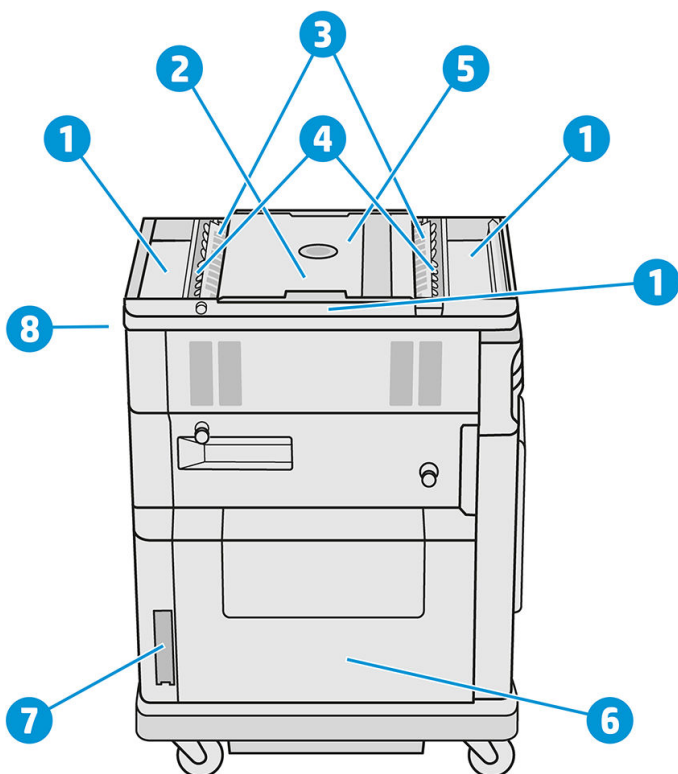

1. Overflow trays (4)
2. Printing platform
3. Feed trays (2)
4. Vane feeders (2)

5. Build chamber
6. Material chamber
7. Material chamber filter
8. Build unit socket

Accessories

The following accessories are available:

- The **natural cooling unit** allows the job to cool outside the processing station, freeing the build unit for another job.
- The **RFID** identifies individual natural cooling units and the jobs contained in them, by radio frequency, enabling job tracking for easier monitoring and analysis.
- The **semaphore** indicates the status of the printer, providing efficient tracking of the printer's functionality and requirements.

See also [Ordering information on page 255](#).

Front panel

The front panel is a touch-sensitive screen with a graphical user interface. There is a front panel on the front left of the printer and another on the front right of the processing station. Each front panel is attached to a movable arm, allowing you to adjust it to a comfortable working position.

The front panel gives you complete control of your printer and processing station: from the front panel, you can view information about the device, change device settings, monitor device status, and perform tasks such as supplies replacement and calibrations. The front panel displays alerts (warning and error messages) when necessary.

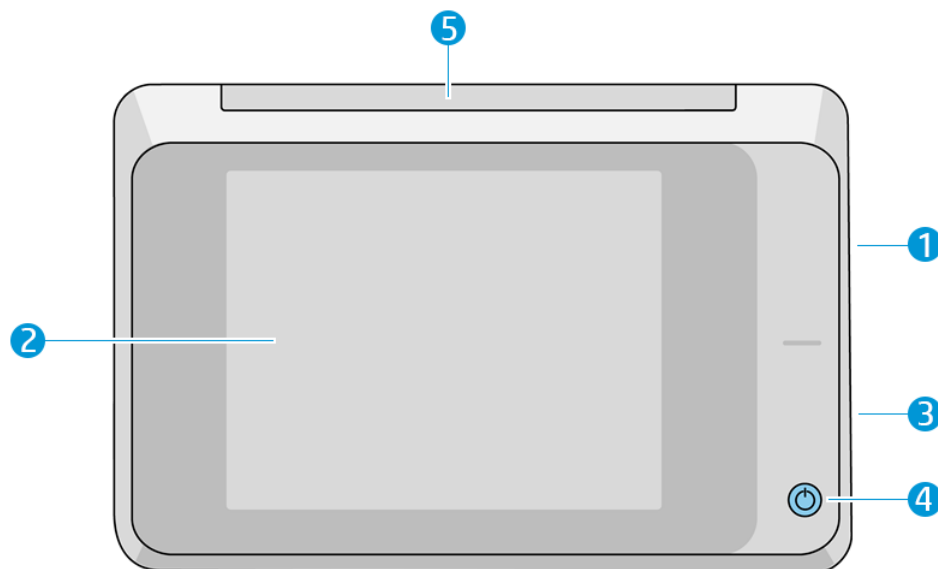



It includes the following components:

1. A Hi-Speed USB host port, intended for connecting a USB flash drive, which can provide firmware update files to the printer
2. The front panel itself: an 8 inch, full-color, touch-sensitive screen with a graphical user interface
3. The loudspeaker

4. The power key
5. The beacon

The front panel has a large central area to display dynamic information and icons. On the left and right sides you can see some fixed icons at different times. Normally they are not all displayed at the same time.

Left and right fixed icons

- Tap  to return to the home screen.
- Tap  to go back to the previous screen. This does not discard any changes made in the current screen.
- Tap  to cancel the current process.

Home screens

There are two top-level screens that you can move between by sliding your finger across the screen, or tapping the appropriate button at the bottom of the screen:

- The first main screen provides direct access to the most important functions.

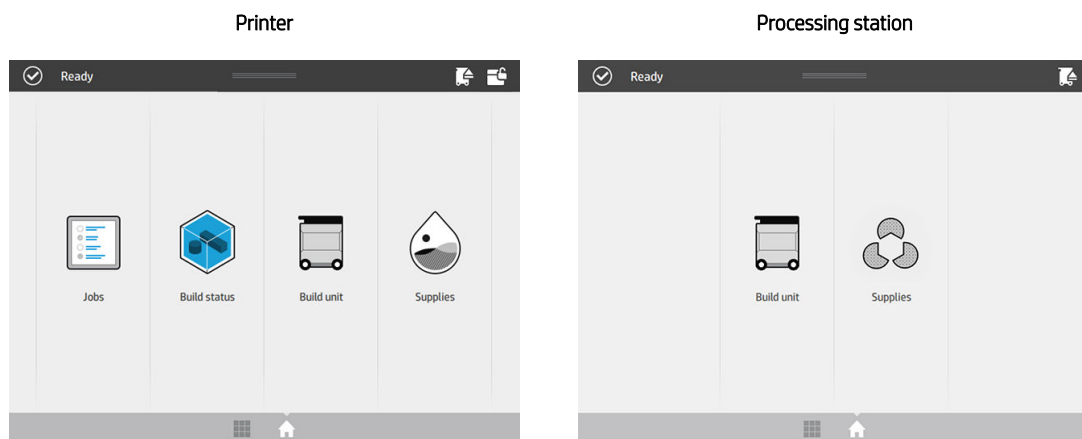

- The all-app screen displays a list of all available apps.

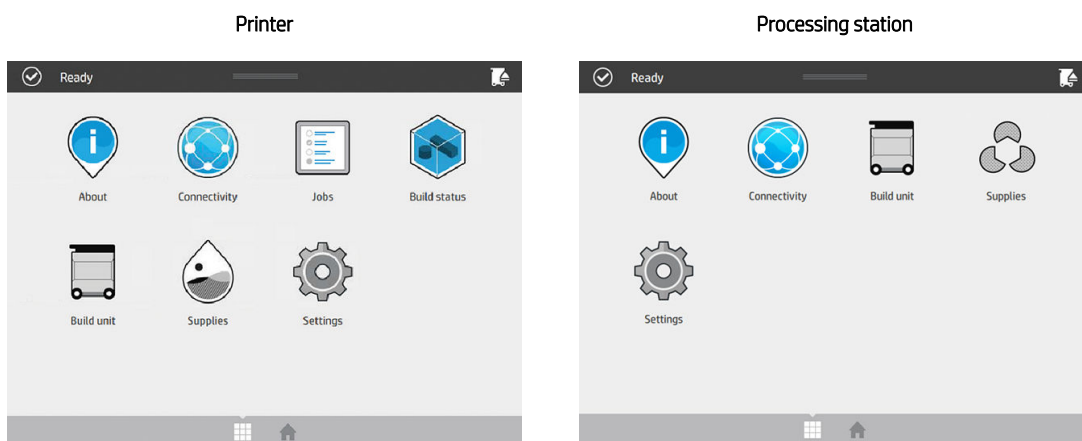

Status center

At the top of the front panel is the status center, which can be expanded by swiping down from the top. This is visible on almost all screens, except when an action is taking place. In the status center, you can see the status of the printer or processing station, and can directly cancel its status (for example, **Printing**) and alerts.

There are other actions you can perform from the status center, such as moving the carriage and recoating unit for maintenance, ejecting the build unit, or unlocking the top cover.

Beacon

The printer has a beacon located on top of the front panel; it gives a summary of the printer status that can be seen from a distance.

 **IMPORTANT:** The information provided in the beacon is for functional information purposes only, and is not relevant to your safety. Warning labels on the equipment should always be heeded, regardless of the status indicated by the beacon lights.



White light

The printer is ready.

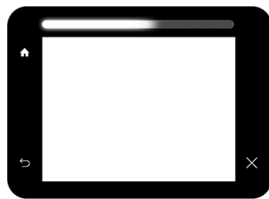

White moving light

The printer is printing or preparing to print.



Yellow light

The printer can print, but there is something wrong. If the problem persists, contact your support representative. While printing, you will see a yellow instead of a white light.

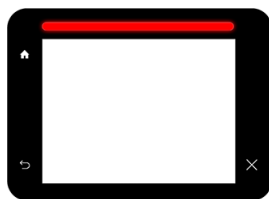

Red light

The printer is unable to print and needs attention, or a major subsystem of the printer is not working.

You can change the beacon settings by tapping , then **System > Beacon**. For example, you can change the brightness of the beacon. You can also turn off beacon warnings and show only definite errors.

Change system options

You can change various printer system options from the front panel. Tap , then **System**.

- **Date and time options** to view or set the printer's date and time.
- **Speaker volume** to change the volume of the printer's loudspeaker. Select **Off**, **Low**, or **High**.
- **Front panel brightness** to change the brightness of the front-panel display. The default brightness is 50.

- **Unit selection** to change the units of measurement in the front-panel display. Select **English** or **Metric**. By default, units are set to **Metric**.
- **Restore factory settings** to restore the printer settings to their original values as set in the factory. This option restores all of the printer settings except the Gigabit Ethernet settings.

Set the administrator password

You can set the administrator password from the front panel. Tap , then **Security > Administrator**

password, and enter the password. If a password has already been set, you will need to give the old password in order to set a new one.

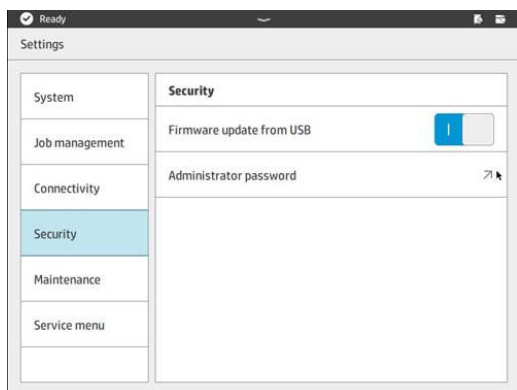

The administrator password must be given in order to change printer settings.

Software

HP software for your 3D printing solution can be downloaded from the following places:

- <http://www.hp.com/go/jetfusion3D5200/software>
- <http://www.hp.com/go/jetfusion3D5210/software>
- <http://www.hp.com/go/jetfusion3D5210pro/software>
- <http://www.hp.com/go/jetfusion3Dprocessingstation/software>

HP SmartStream 3D Command Center

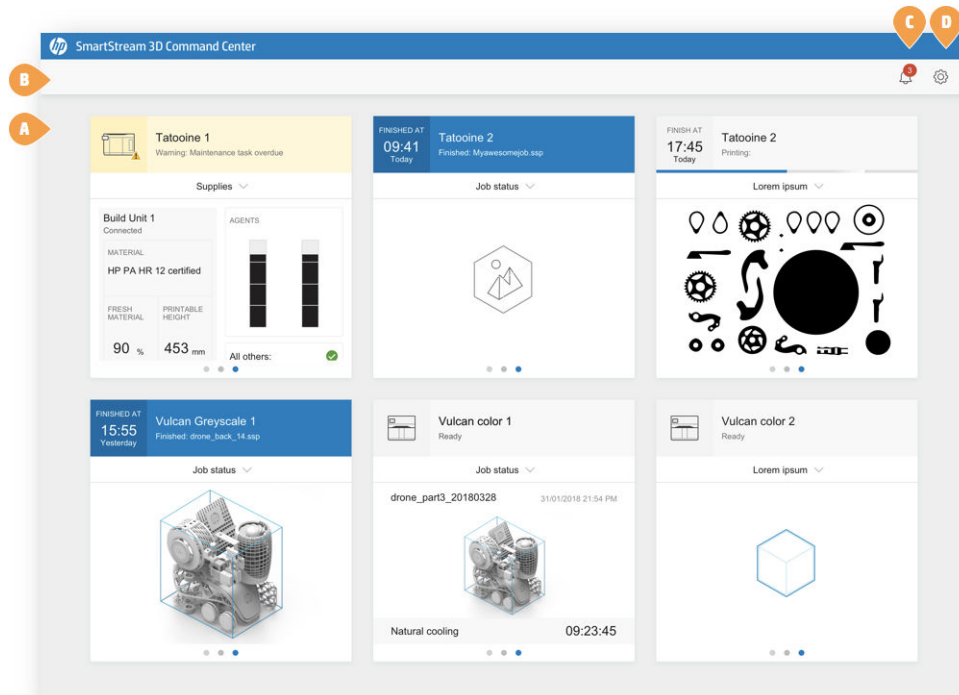

Each device is represented by a card that summarizes the most important information about the device. By default, the build status information is shown.

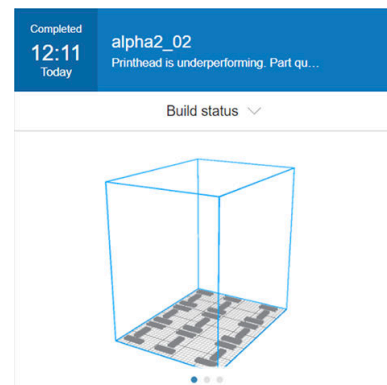
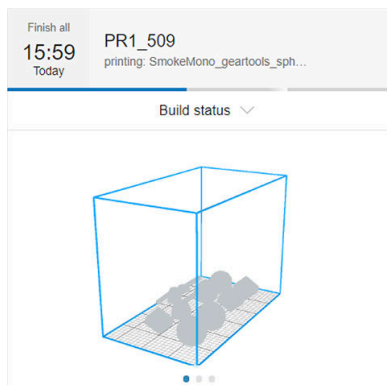

The upper part of the card shows the following information:

- Icon that helps to identify the type of device.
- Shows the expected finish time, if a part is being built.
- Name of the device chosen by the user who registered it in Command Center.
- Current status of the device.

You can use the drop-down menu to view information on builds and supplies.

Builds

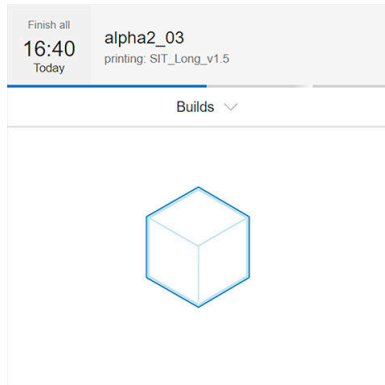

Supplies

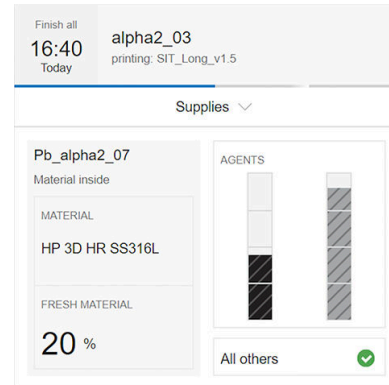

Click the card for more detailed information about the device.

The Build status tab

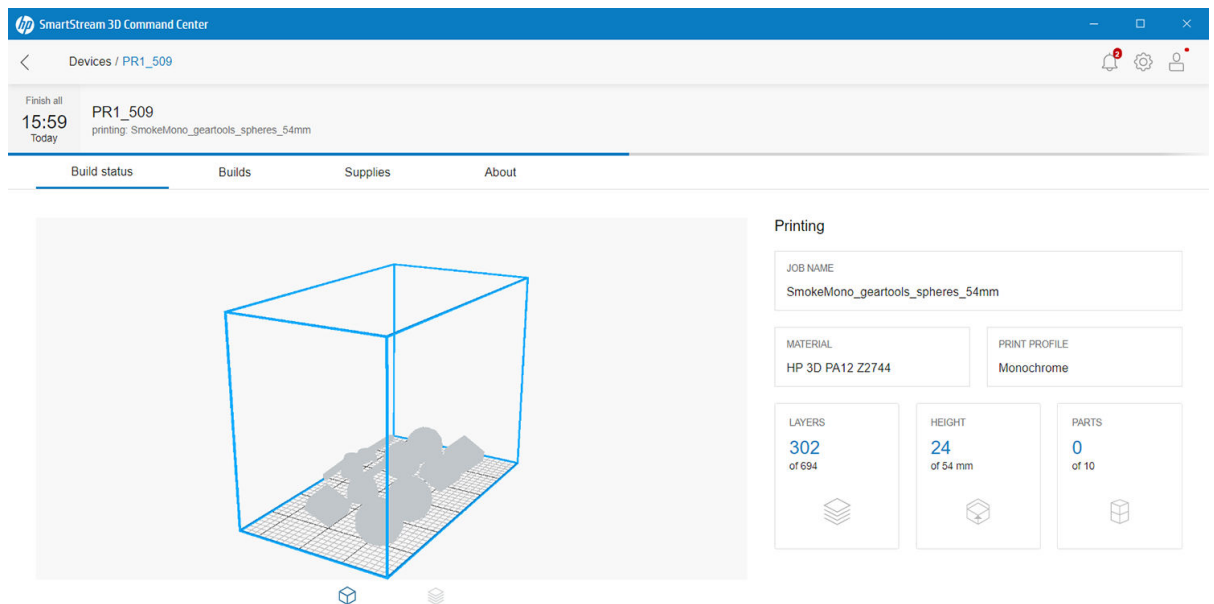

The Builds tab

The screenshot shows the HP SmartStream 3D Command Center interface. At the top, the title bar reads "hp SmartStream 3D Command Center". Below it, the breadcrumb navigation shows "Devices / PR1_509". The main header area displays "Finish all 15:59 Today" and "PR1_509 printing: SmokeMono_geartools_spheres_54mm". A navigation bar contains "Build status", "Builds", "Supplies", and "About", with "Builds" being the active tab. The main content area is mostly blank, featuring a large blue number "2" above the word "pending" and a downward-pointing arrow icon.

The Supplies tab

The screenshot shows the HP SmartStream 3D Command Center interface with the "Supplies" tab selected. The title bar is "hp SmartStream 3D Command Center" and the breadcrumb is "Devices / Target 19.31". The header shows "Finish all 12:44 Today" and "Target 19.31 printing: thinjob". The navigation bar includes "Build status", "Builds", "Supplies", and "About", with "Supplies" being the active tab. The main content area is divided into several sections: "TROLLEY_0 Material inside" with "MATERIAL HP 3D HR PA12" and "FRESH MATERIAL 20%"; "Agents" with two vertical bars labeled "F" and "D", both at "100%"; and "Printheads" with two vertical bars and a "Select to see information" button.

The About tab

The screenshot shows the 'About' tab in the HP SmartStream 3D Command Center. The interface includes a top navigation bar with the HP logo and 'SmartStream 3D Command Center'. Below this is a breadcrumb trail 'Devices / Target 19.31'. A status bar at the top left shows 'FINISH ALL 12:36 TODAY' and 'Target 19.31 Printing: Thinjob'. The main content area has four tabs: 'Build status', 'Builds', 'Supplies', and 'About' (which is selected). On the left is a large image of the HP Jet Fusion 3D 5200 Printer. On the right, the 'About' section provides the following information:

- Target 19.31**
HP Jet Fusion 3D 5200 Printer
- SERIAL NUMBER: HPSIMCRAIT
- PRODUCT NUMBER: 3FW25A
- Firmware information**
 - VERSION: CRAITCRAIT_04_18_51.3
 - PUBLISHED DATE: 18. Dec. 1803:31:00
- [Save service info](#)
- [Save diagnostic package](#)
- [Certificate of installation](#)
To be filled in after installation
- Help & Support**
 - [User guides](#)

© 2019 HP Development company

Click **Back** or the breadcrumb to go back to the monitoring overview area.

Types of devices

Command Center can monitor all models of 3D printers, processing stations, build units, and cooling frames.

3D printers

3D printers have the following sections:

- **Build status:** Information about the ongoing activity of the printer.
While a job is being printed, you can see the following information:
 - JOB NAME
 - MATERIAL
 - PRINT PROFILE
 - LAYERS: The number of layers printed, and the total number of layers to print
 - HEIGHT: The height printed, and the total height to print
 - PARTS: The number of parts printed, and the total number of parts to print
- **Builds:** Information about the current job file that is being printed, the upcoming jobs, and the pending jobs to be printed.
 - UPCOMING JOB: This appears only when a new job has been submitted while the current job is printing, to be printed in the same build chamber
 - PENDING JOBS: Jobs that are already stored in the printer, waiting to be printed when selected
- **Supplies:** Information about the health of all your supplies, with further information in case of any warning or error.

 **NOTE:** Different printer models may have different types of supplies.

- BUILD UNIT: Shows the status of the build unit and type of material in the build chamber, if the printer supports build units.
- FRESH MATERIAL: The percentage of material that is fresh (from a material cartridge); the rest of the material is from the storage tank.
- AGENTS: A real-time display of the level of the agents.
- PRINTHEADS: Displays alerts or errors if any.
- OTHER SUPPLIES: Displays alerts or errors if any.
- FUSING LAMPS: Displays alerts or errors if any.
- HEATING LAMPS: Displays alerts or errors if any.
- **About:** Information about the printer, such as model and product number, as well as a link to activate the warranty, and a link to the printer's user guide.

Processing stations

- **Printed builds:** Shows the job files that have been printed inside the inserted build unit.
- **Supplies:** Information about the health of all your supplies, with further information in case of any warning or error.

 **NOTE:** Different printer models may have different types of supplies.

- **About:** Information about the processing station, such as model and product number, as well as a link to activate the warranty, and a link to the processing station's user guide.

Device alerts

Cards may display warnings or errors, which may override the printer status, depending on their importance, which is determined by the printer.

- **Warnings** are about non-urgent issues, such as a maintenance routine. A warning about a particular component is displayed on the icon representing that component.

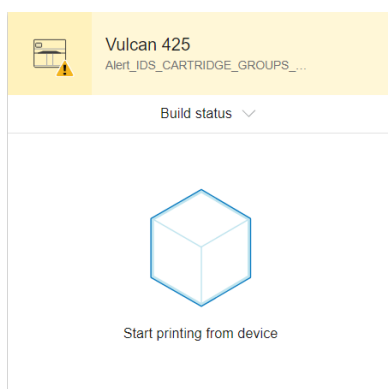

- **Errors** are about urgent issues that could stop the printer from starting a job, such as a broken lamp. An error about a particular component is displayed on the icon representing that component.

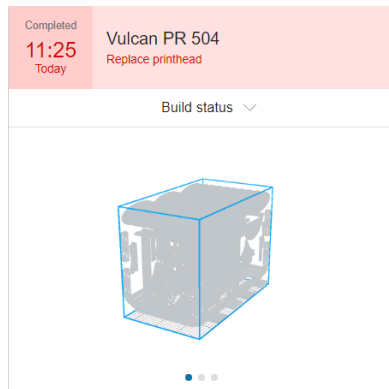

HP SmartStream 3D Build Manager

Use the powerful 3D print-preparation capabilities of HP SmartStream 3D Build Manager to help make all of your 3D printing jobs successful:

1. Add parts to begin preparing the print job.
2. Rotate, size, and position the part on the bed.
3. Automatically locate and fix 3D geometry errors.
4. Send a printer-ready file to a connected 3D printer or save the printable file.

You can find more information about the Build Manager in the *HP SmartStream 3D Build Manager User Guide*: see [Documentation on page 2](#).

4 Power on and off

NOTICE: Operate the equipment only within the specified ranges of operating temperature and humidity (see the site preparation guide). If the equipment or supplies are exposed to conditions outside the environmental operating range, wait at least 4 hours for everything to reach environmental operating conditions before turning on the equipment or using the supplies.

- [Turn the printer on and off](#)
- [Turn the processing station on and off](#)
- [Circuit-breaker labels](#)

Turn the printer on and off

Turn on the printer for the first time

1. Make sure that the two bottom rows of circuit breakers at the front right of the printer are all in the up position and that the three green lamps are on. If any of them are off, check with your electrician.

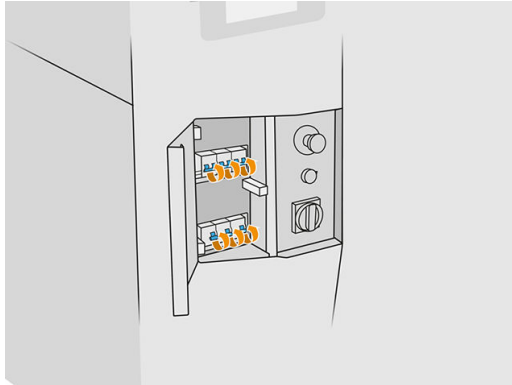

2. Turn the main switch to the on position.



3. Wait for the front panel to tell you that the printer is waiting for rearm.
4. Perform a visual check of the printer.
5. Press the blue rearm button at the front left of the printer. This enables all of the printer's high-power subsystems.
6. Wait for the front panel to indicate that the printer is ready. This can take several minutes. When initialization is complete, the front panel displays a **Ready** message. If a system error message is displayed, see [System errors on page 256](#).

Turn the printer on and off

The printer has two power-off levels. Level 1 is recommended if you intend to use the printer again soon. Otherwise, you are recommended to use level 2, which is complete shutdown.

Level	Turn off	Turn on
1: Standby (5 V)	Front-panel power button off	Front-panel power button on
2: All printer systems off	<ol style="list-style-type: none">1. Front-panel power button off2. Red main power switch off	<ol style="list-style-type: none">1. Red main power switch on2. Front-panel power button on

Turn the processing station on and off

Turn on the processing station for the first time

1. Make sure that the wheels are braked: the processing station should remain stationary while operating.
2. Make sure that the two bottom rows of circuit breakers at the front right of the station are all in the up position.

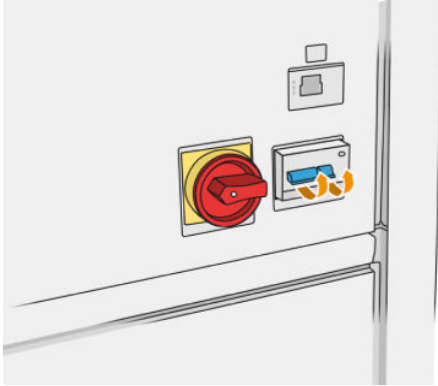

3. Turn the service switch to the on position.

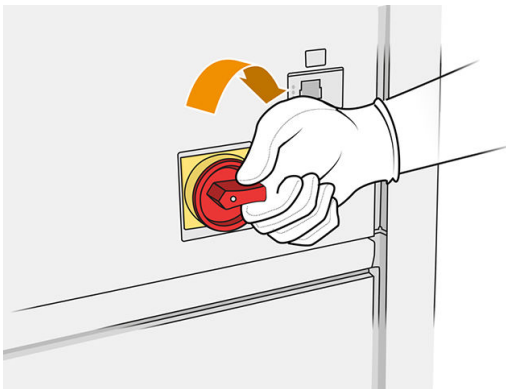







4. Perform a visual check of the station.
5. Wait for the front panel to indicate that the station is ready. This can take several minutes. When initialization is complete, the front panel displays a **Ready** message. If a system error message is displayed, see [System errors on page 256](#).

Turn the processing station on and off

The station has two power-off levels. Level 1 is recommended if you intend to use the station again soon. Otherwise, you are recommended to use level 2, which is complete shutdown.

Level	Turn off	Turn on
1: Standby (5 V)	Front-panel power button off	Front-panel power button on
2: All processing-station systems off	<ol style="list-style-type: none">1. Front-panel power button off2. Red main power switch off	<ol style="list-style-type: none">1. Red main power switch on2. Front-panel power button on

Circuit-breaker labels

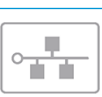
Label	Description
	Main power
	DC power
	E-box
	Build unit
	Fusing lamps
	Heating lamps
	Rearm
	LAN

5 Printer and processing station networking

The printer provides a single RJ-45 port for a network connection. In order to meet Class B specifications, the use of shielded I/O cables is required. For optimal performance, you are recommended to use Cat 5/5e or Cat 6 cabling and gigabit-capable local network equipment.

A correct network setup is required to operate the printer, as all communication with printing and management software happens through the network.

Connectivity and remote monitoring requirements

Definitions

- **Product(s)** means the HP-branded 3D printing hardware and any related HP-branded 3D printing accessories, including but not limited to the 3D printer, processing station, and build unit, as well as any accompanying HP-branded 3D software, listed in the customer order and excluding consumables or services.
- **Site Preparation Guide** means the site preparation guide for the Product that has been provided to the customer by HP or HP authorized personnel (either online or in paper form) in advance of the sale of the Product.
- **Customer Computer** means the computer, as further specified in the Site Preparation Guide, provided by the customer at the customer's sole expense, which will be hosting the required HP 3D software necessary to manage the Product(s).
- **Customer Machine Data** means data collected from the customer's Product that may include, but is not limited to the following: Product usage data; Product production data; Product system events; Product maintenance and calibration history; Product model number; Product serial number; Product firmware version; Product IP address; consumables status and history; sensors activity; quantity and type of printheads used; build ID; build duration; and/or print mode. Customer Machine Data does not include: design files, parts files, job names, job contents, part geometries, thermal maps, user names or part names.

Requirements

- a. The customer will allow HP to install the required HP 3D software on the Customer Computer, keep the Customer Computer connected to the Product, and keep such HP 3D software running on the Customer Computer at all times.
- b. The customer will provide, at the customer's sole expense, HP 3D software connectivity to the HP secure cloud via permanent Internet connection through an HP-approved communications channel and will ensure such connectivity at all times as further specified in the Site Preparation Guide. The customer is responsible for restoring connectivity in a commercially reasonable timely manner in the event of unforeseen interruptions.
- c. THE CUSTOMER AGREES THAT FAILURE TO MAINTAIN THE PRODUCT'S CONNECTION TO THE HP CLOUD AS SPECIFIED IN THE SITE PREPARATION GUIDE WILL RESULT IN LIMITED OR NO PRODUCT FUNCTIONALITY AND LIMITED SERVICE LEVEL.

- d. Products may collect Customer Machine Data. The customer grants HP and/or an HP authorized agent permission to remotely access, via the HP 3D software, the Customer Machine Data from Products. The Customer Machine Data will be used by HP and/or an HP authorized agent for the purpose of providing remote support, enabling enhanced diagnostics, preventive maintenance, software updating, calculating supplies and consumables usage and statistics, and evaluating improvements to HP's products and offerings in the future. In addition, the Customer Machine Data will help HP determine how Products are being used, which product features are used the most, and to calculate various aggregate Product usage statistics.
- e. HP and/or HP authorized agents respect your privacy, are committed to protecting Customer Machine Data, and will take reasonable precautions to prevent unauthorized access or disclosure and ensure the appropriate use of Customer Machine Data. In the event that some data may be categorized as individual level data, HP and/or HP authorized agents will maintain the privacy of any such data, as well as all data collected, in accordance with the HP Privacy Statement (<http://www.hp.com/go/privacy>) and the Personal Data Rights Notice (<http://welcome.hp.com/country/privacy/privacynotice>) where applicable.

Configuration

To access the network settings, tap  and then  on the front panel.

Hostname

You can assign a customized hostname to the printer. If the network infrastructure supports it, the printer will attempt to register the hostname to the DNS service, making it possible to address the printer using the hostname rather than the IP address.

Similarly, you can assign the domain suffix, to define the printer's fully qualified domain name.

IPv4 configuration

You can select whether the printer should try to discover automatically the IPv4 network settings using the DHCP protocol, or whether you want to configure them manually. These settings include:

- **IP address:** The unique Internet Protocol address assigned to the printer.
- **Subnet mask:** The mask corresponding to the printer's IP address.
- **Default gateway:** The IP address of the network gateway.
- **DNS configuration method:** Whether DNS servers should be assigned by DHCP service or manually.
- **Primary and secondary DNS servers:** The IP addresses of the DNS servers.

Link speed

The embedded network controller supports connection to IEEE 802.3 10Base-T Ethernet, IEEE 802.3u 100Base-TX Fast Ethernet, and 802.3ab 1000Base-T Gigabit Ethernet compliant networks. When connected and powered on, the printer auto-negotiates with your network to operate with a link speed of 10, 100, or 1000 Mbps, and to communicate using full- or half-duplex mode. However, you can manually configure the link using the printer's front panel, or through other configuration tools once network communication is established.

Troubleshooting

Link issues

The printer has status lights (LEDs) beside the network connector that indicate the link status and network activity.

- When the green light is on, the printer has successfully linked to the network.
- When the yellow light is blinking, there is transmission activity over the network.

If the printer fails to connect to the network, both LEDs will be off. In this situation, try the following steps:

1. Check the cable connections at both ends.
2. Consider replacing the cables with ones that are known to work.
3. Consider switching to another network connector in the network switch, hub, or device to which the printer is connected.
4. Manually configure the link setting to match the port configuration of the network hub or switch.
5. In case of doubt or misconfiguration of link settings, reset the network parameters to their factory settings.

Restore factory settings

In the case of accidental misconfiguration, you can reset the network settings to the factory defaults by tapping **Restore factory settings** in the Network Settings configuration menu.

6 Consumables

- [Printer](#)
 - [Agents](#)
 - [Printheads](#)
 - [Printhead cleaning roll](#)
 - [Replace the fusing lamps](#)
- [Processing station](#)
 - [Material](#)
 - [Material cartridges](#)
 - [Storage and external tanks](#)
- [How to recycle supplies](#)

Printer

Agents

There are two kinds of agents: fusing and detailing agents.

The printer accepts agent cartridges with a capacity of 3 or 5 liters.

Please note:

- This is a dynamic security-enabled printer. Cartridges using a non-HP chip may not work, and those that work today may not work in the future. For more information, see <http://www.hp.com/go/learnaboutsupplies>.
- This printer is not designed to use continuous agent systems. To print successfully, remove any continuous agent system and install genuine HP cartridges.
- This printer is designed for HP-approved agent cartridges to be used until they are empty. When a cartridge is empty, insert a new cartridge to continue printing. Do not refill the cartridge.

Status

At the printer's front panel, tap , then **Agents**, then tap any agent to see its status:

- **Missing:** The agent is missing.
- **Empty:** The agent is empty and should be replaced.
- **Replace:** The agent is faulty and should be replaced.
- **Reseat:** The agent is not responding; removing and reinserting it may solve the problem.
- **Wrong:** The agent type is not suitable for this printer.
- **Expired:** The agent has reached its expiration date. Using expired agents may affect the warranty on your printheads.
- **Low on agents:** The agent is low and should be replaced soon.
- **Very low on agents:** The agent is very low and should be replaced soon.
- **Incorrect**
- **Non-HP**
- **OK:** The agent is working normally.
- **Out of agents:** The agents should be replaced.



NOTE: The level of each agent shown on the front panel is an estimate.

LEDs

- **White:** OK
- **Yellow:** Warning
- **Red:** Error, out of agent

Replace an agent

 **NOTE:** You can replace the agent cartridges while printing continues, because the printer is supplied from the intermediate tanks.

1. At the printer's front panel, tap , then **Agents > Replace**.
2. Press the agent door to release it, and open the door.

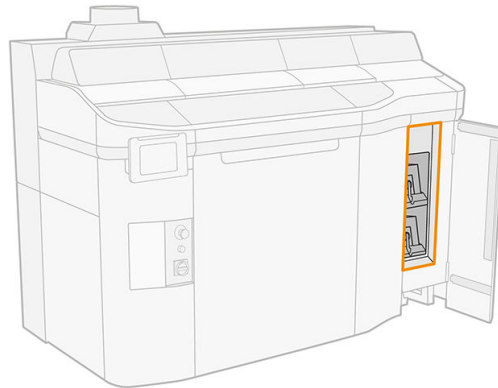
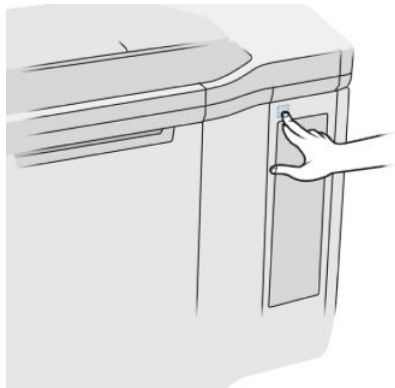

3. Locate the agent to be replaced. You can see which agent needs to be replaced on the front panel; it is also indicated by a red LED beside the cartridge.
4. Disconnect the agent connector by pressing the tabs on each side of it and pulling it away gently.

 **TIP:** When removing or inserting an agent connector, rotate it clockwise a little to avoid interference between the connector and the agent box.

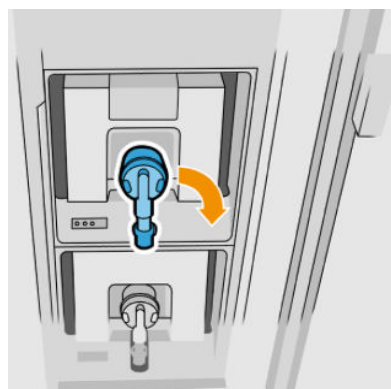

5. Remove the agent.

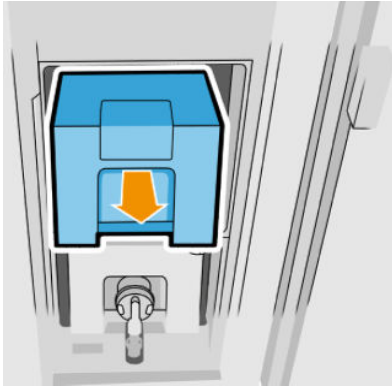

6. Dispose of the old agent, following the instructions on the packaging. The agent bag should be removed and disposed of in compliance with federal, state, and local regulations. The other agent parts (plastic retainer and packaging box) can be recycled through commonly available recycling programs. HP recommends that you wear gloves when handling supplies.
7. Remove the new agent from its packaging, place it on a flat surface, and turn it four times (rotating it through 360 degrees) as indicated on the label, to ensure that the agent is well mixed before use.

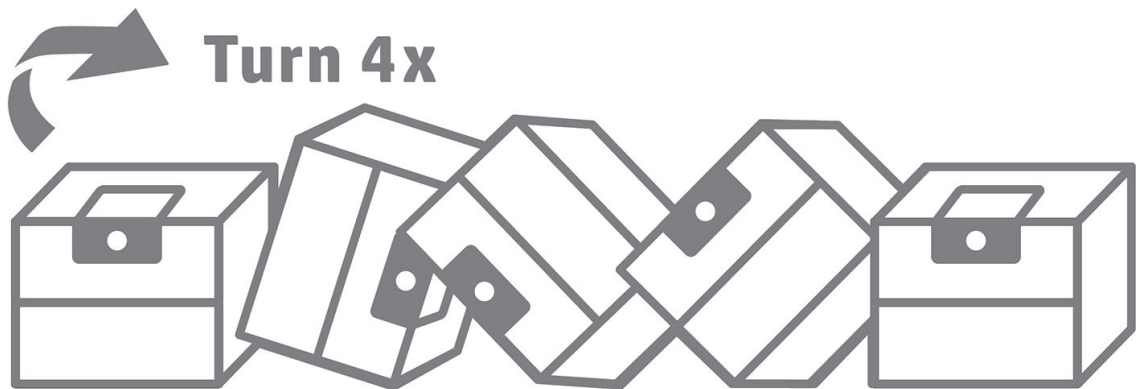

8. Push down and fold inward the top part of the handle. Do not cut it.
9. With one hand on the bottom of the agent and the other on the fold, put the new agent into its correct place in the printer.
10. Without pressing the tabs, connect the agent connector to the cartridge.

 **IMPORTANT:** If you press the tabs when connecting it, the agent will not be locked.

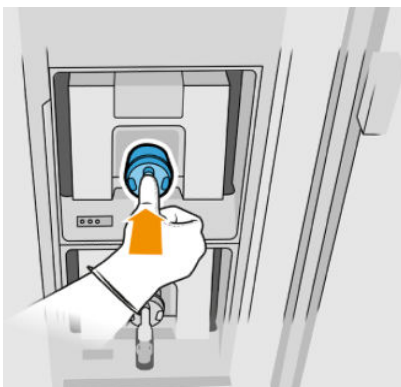

11. Ensure that the tabs on each side of the agent connector are open but in place, showing a successful connection. You will hear a click.

12. Close the door.
13. Tap **Finish** and **Check** on the front panel.

TIP: If the new agent fails to work, follow the troubleshooting procedure below. The problem may be with the connector rather than the agent itself.

Agent troubleshooting

1. Check that the agent is designed for your printer.
2. Use the correct procedure to change agents, through the front panel.
3. Check that there is no obstruction in the agent connector.
4. Check that the agent is of the correct type (fusing or detailing agent). The wrong type will not match the connector.
5. Check that the agent connector is correctly oriented (compare with another agent).
6. Ensure that you have inserted the connector correctly and fully. You should hear a click.
7. Ensure that the tabs on each side of the agent connector are open but in place, showing a successful connection.
8. Check the agent connector. You may find that the agent connectors have become bent while the agent was disconnected. This means that they cannot connect properly, and you will see a reseal message. To correct this problem, use pliers to straighten the connectors so that they will fit into their slots.
9. If the problem still remains, call your support representative.

Printheads

The printheads take agents and deposit them on the build.

CAUTION: Observe precautions when handling printheads because they are ESD-sensitive devices (sensitive to ElectroStatic Discharges). Avoid touching pins, leads, and circuitry.

The printer's writing system uses three dual-agent printheads with 31,680 nozzles each; so each agent has 15,840 nozzles. The printheads are numbered as shown below.

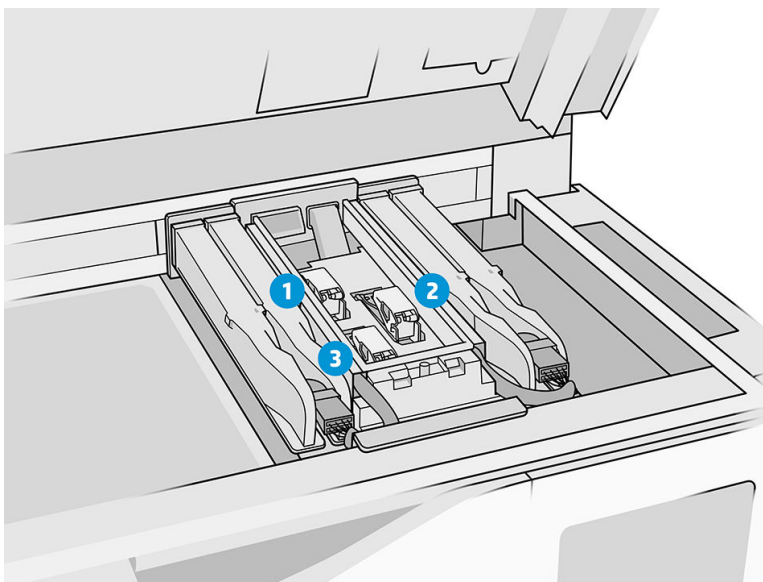

1. Rear printhead
2. Middle printhead
3. Front printhead

Printheads should be stored vertically: if boxed, with the box arrows pointing up; if out of the box, with the nozzle cap up.

Status

At the printer's front panel, tap , then **Printheads**, then tap any printhead to see its status:

- **OK:** The printhead is working normally.
- **Check pending**
- **Missing:** The printhead is missing.
- **Error**
- **Warning**
- **Non-HP**

Replace a printhead

1. At the printer's front panel, tap , then **Printheads > Replace**.
2. Put on gloves.
3. Open the top cover.

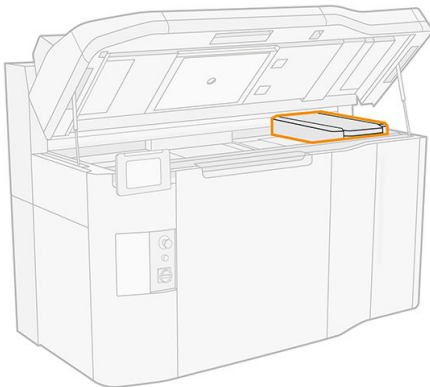

4. Pull the handle to open the printhead cover.

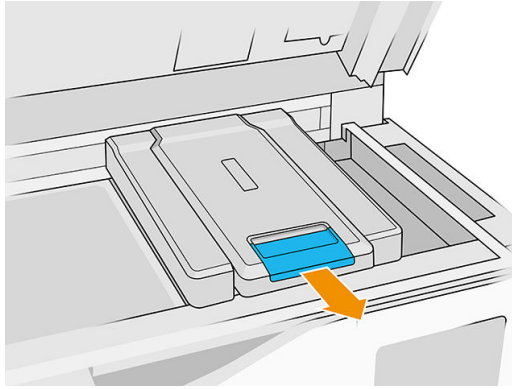

5. Lift off the printhead cover.

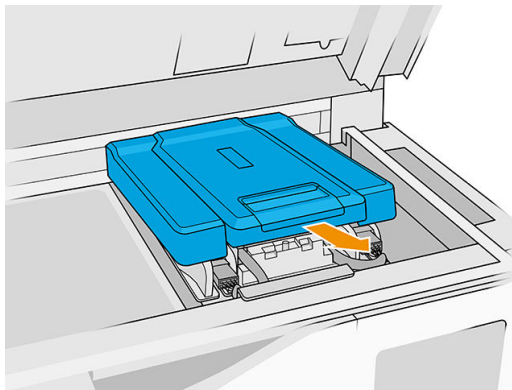

6. Release the printhead latch.

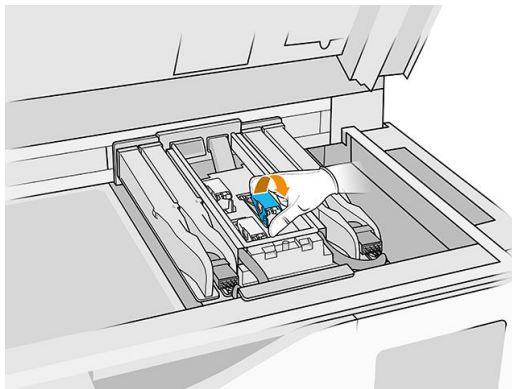

7. Lift the printhead latch.

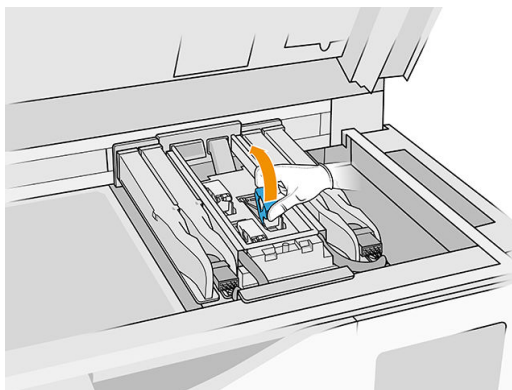

8. Place the extraction tool on the left side of the printhead.

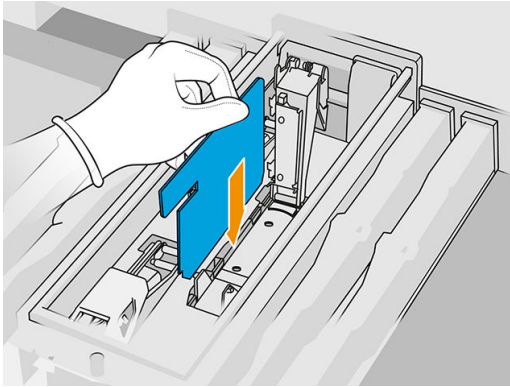

9. Lift the printhead handle, and pull it gently upwards to disconnect the printhead from the carriage.

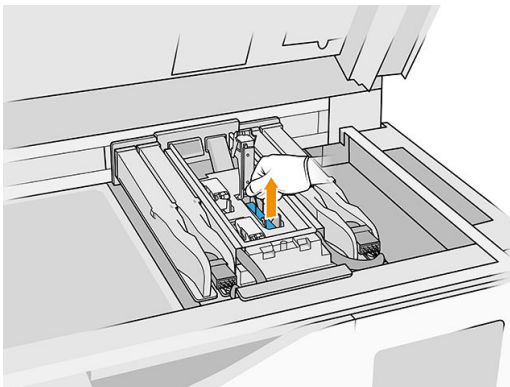

10. After removing the printhead, remove the extraction tool, and clean it with a lint-free cloth dampened with deionized water.
11. Dispose of the old printhead in accordance with local regulations. Most HP printheads can be recycled through the HP supplies recycling program. For more information, see <http://www.hp.com/recycle/>. HP recommends that you wear gloves when handling supplies.
12. Shake the printhead according to the instructions on its packaging.

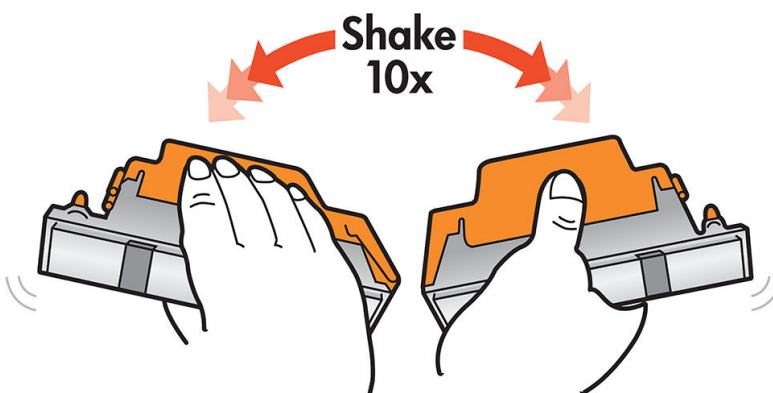

13. Remove its packaging and protective caps.

 **TIP:** You may wish to keep the protective caps for later reuse, in case you ever want to remove a printhead from the printer temporarily.

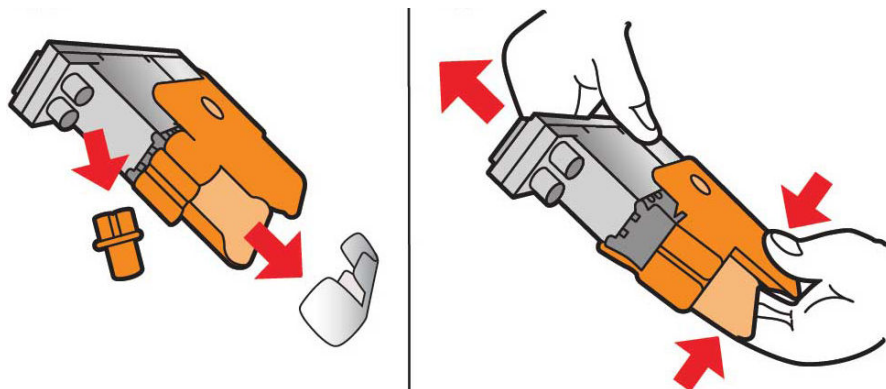

14. Put the new printhead into its correct place in the printer, and lower its handle.

 **CAUTION:** Insert the printhead slowly, without hitting any parts of the carriage. It may be damaged if you insert it too fast, or if you hit something.

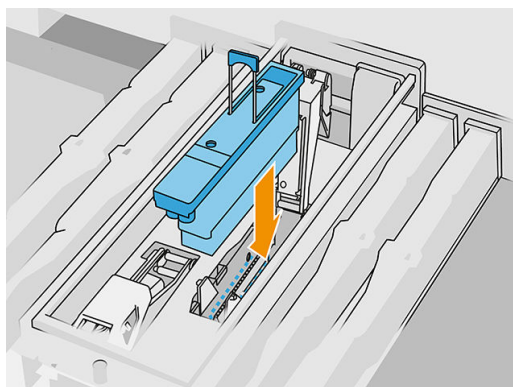

15. Lower the latch until it lies on the printhead.

16. Close and secure the latch.

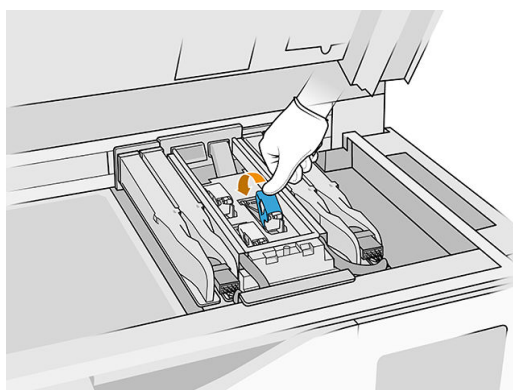

17. Put the printhead cover back into place.

18. Close the top cover.
19. Tap **Finish** and **Check**. The printer checks that the new printhead has been correctly inserted, and recommends printhead alignment. See [Align the printheads on page 230](#).

If the printhead alignment process is canceled, the printer will not print.

 **NOTE:** If the new printhead is rejected or you are asked to reseal it, try cleaning the printhead contacts (see [Clean the printhead contacts on page 159](#) and [System errors on page 256](#)).

Printhead cleaning roll

The printhead cleaning roll is a roll of absorbent material used in the normal operation of the printer to wipe the printheads periodically: at the beginning and end of printing, while printing, on printhead check and clean, and so on. This helps the printheads to deliver agents continuously and maintain print quality.

The roll should be replaced whenever it is used up, to avoid damaging the printheads. The frequency of replacement depends on your use of the printer. A single roll will last approximately 40 full jobs of 4750 layers each with PA12 in balanced print mode.

An alert is displayed when 75% of the roll has been used, and again when 95% of it has been used. You can choose to replace the roll at any time. The printer will not print when the roll has been 100% used.

If there is not enough of the roll to finish a new job, the printer will not start the job.

At the printer's front panel, tap , then **Printhead cleaning roll** to see the status of the roll.

 **TIP:** You should not touch the printhead cleaning roll except when you need to replace it. Any interference with the roll may prevent the printer from keeping track of roll usage, in which case you may see spurious error messages, and a printing job may be canceled unnecessarily.

Replace the printhead cleaning roll

1. Ensure that you have a new cleaning roll ready.



2. Put on gloves.
3. At the printer's front panel, tap , then **Printhead cleaning roll > Replace**.
4. Tap **Start** when ready.
5. Open the agent door and the cleaning-roll doors.

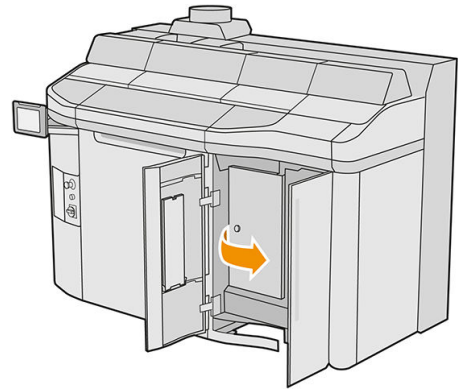
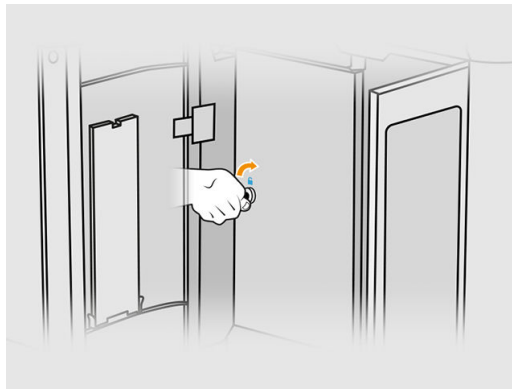

6. Open the top cover.
7. Detach the end of the cleaning roll from the upper roll core.

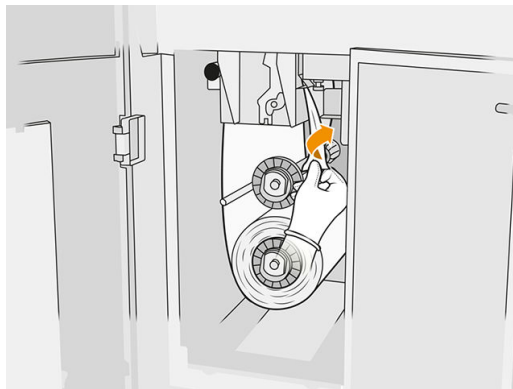

8. Pull the black knob at the top left and move the pinch system aside.

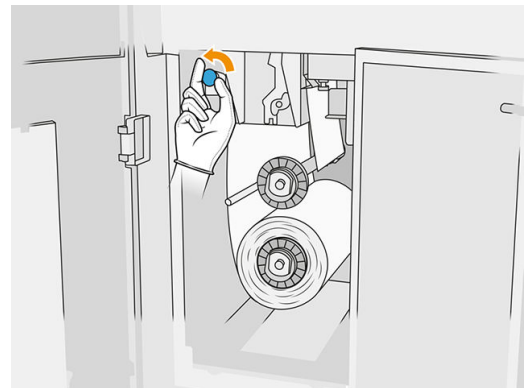

9. Clean the rubber blade, the roll input, and the cleaning roll platen with the end of the roll.

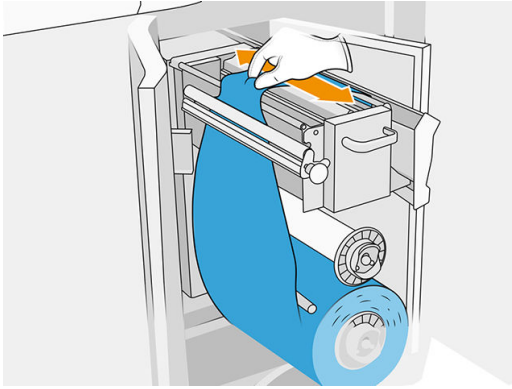

10. Wind the remainder of the cleaning roll onto the lower axle.

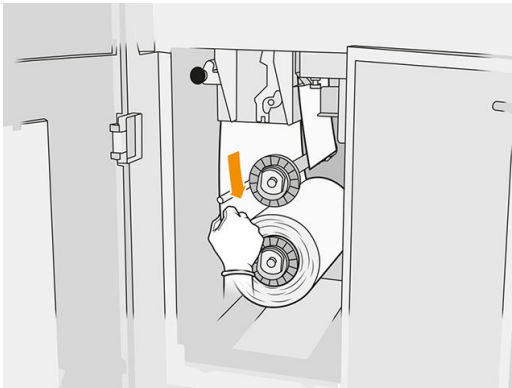

11. Remove the hub of the lower roll by pressing on the tab, then remove the lower roll.

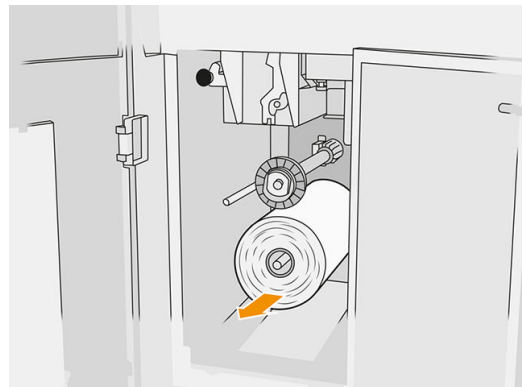

Dispose of the roll of used cleaning material according to the instructions provided with the new roll. Also consult your local authorities to determine the correct manner in which to dispose of wastes.

12. Remove the hub of the upper roll, then remove the roll core and place it on the lower axle.



13. Place the lower hub, pull the core against the hub, and push them both in until the hub snaps into place (you will hear a click).

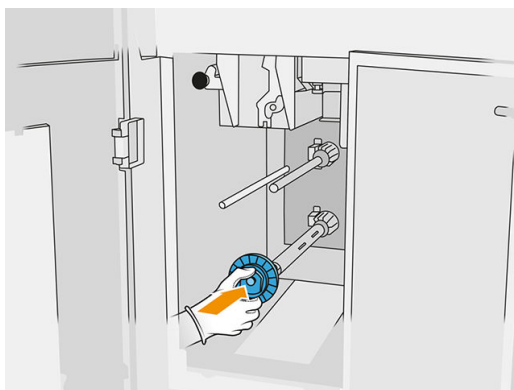

14. Place the upper hub onto the new roll, and slide them onto the upper axle until you hear a click.

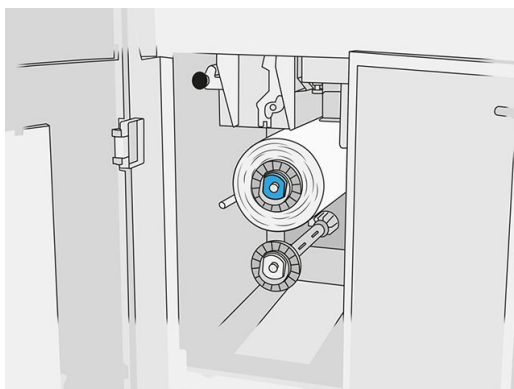

⚠ CAUTION: Make sure the cloth is aligned with the front of the core, touching the hub. If you push the roll by the cloth when placing the new roll, you could detach the cloth from the core, causing problems while printing.

15. Pass the leading edge of the roll over the upper rollers, and thread the cleaning material through the rollers on the left.

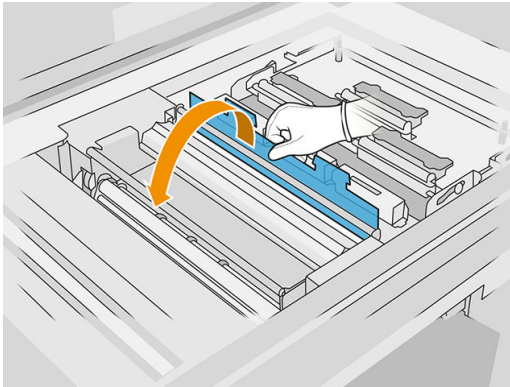

16. There is a strip of polyester film on the leading edge of the cleaning material. Insert it into the hole in the takeup core, which takes hold of it.

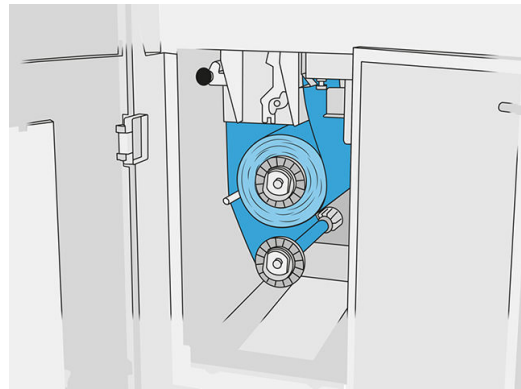
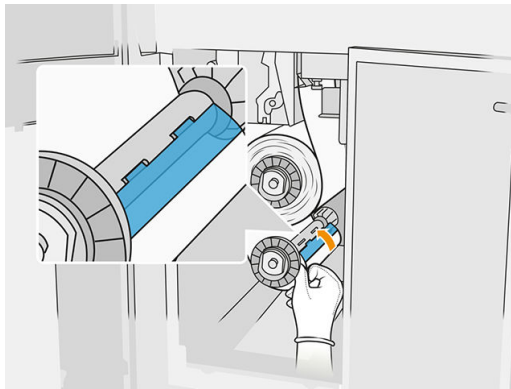

Take care to route the cleaning material correctly.

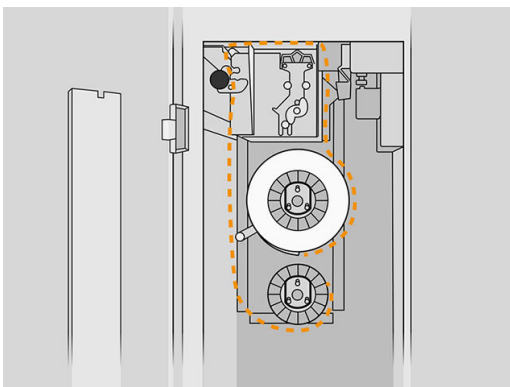

17. Rotate the lower roll one full turn.

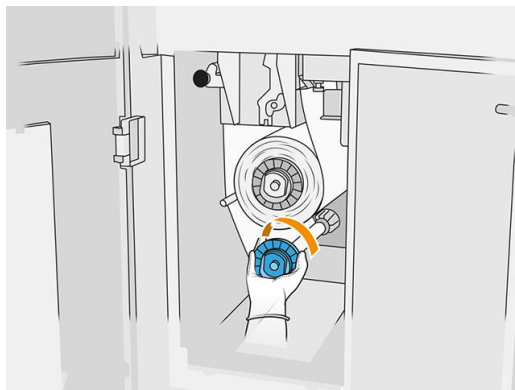

18. Restore the pinch system by moving the black knob back into place. If you feel resistance because the cleaning roll is too tight, turn the roll slightly counter-clockwise.

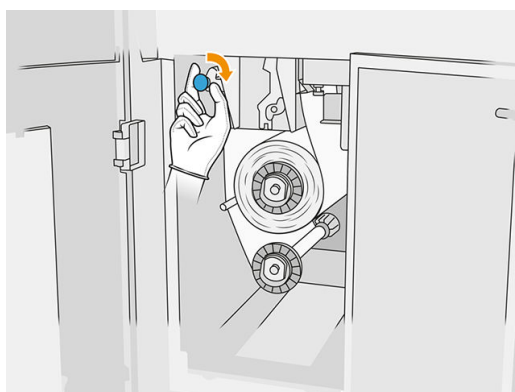

19. Close and lock the doors.

The length of used printhead cleaning roll tracked by the printer is now reset to zero.

 **NOTE:** If you tamper with partly-used rolls, the usage shown in the front panel will not be accurate.

20. Tap **OK** on the front panel.

Replace the fusing lamps

At the printer's front panel, tap , then **Fusing lamps** to see the status of each lamp:

- **Missing:** The lamp is missing.
- **Replace:** The lamp has been identified as faulty. It should be replaced by a functional lamp.
- **Wrong:** The lamp type is not suitable for this printer.
- **Not in warranty:** The lamp is no longer covered by warranty.

Prepare for replacement

1. Ensure that you have the fusing lamp kit, which is included in the printer initial maintenance kit, but can also be purchased separately.
2. Ensure that the printer is not printing.
3. If a job has just been printed, wait about 20 minutes for the printer to cool down.

4. You are recommended to wear cotton gloves and mask.
5. Ensure that all windows, covers, and doors are closed and remain in their original positions.
6. Turn off the printer.



Risk of burns



Crush hazard



Risk of trapped fingers



Hazardous moving part



Light radiation hazard



Electric shock hazard

For more safety information, see [Safety precautions on page 5](#)

Remove the fusing-lamp module

- ▲ See [Remove the fusing-lamp module on page 151](#).

Safety precautions for the fusing-lamp emitter

- Disregard of the safety precautions or improper operation of the infrared emitter can lead to injuries and material damage.
- The IR heating device should be operated only by specialists or trained personnel.
The operator of the system should compile specific instructions for personnel training.
- The safety and functional reliability of the IR heating device are guaranteed only if you are using original accessories and spare parts from HP.
- After an emitter break, a dangerous voltage may be exposed to contact by the heating spiral.
- The reflector side should not be cleaned.

Transport and handling of the fusing-lamp emitter

- Transport the IR emitter, in the packaging provided, to the place of installation.

⚠ CAUTION: If the IR emitter must be transported without its packaging, wear linen gloves. Fingerprints on the quartz tube will cause devitrification, which leads to radiation losses and mechanical failure.

- Always carry the emitter with both hands. Carry it so that the cross-section faces up, to avoid bending and breaking.
- Grip the emitter only by the glass tube, and not by the connection cable, pinches, or ceramics.

When installing IR emitters

- HP recommends that you wear protective goggles when installing or replacing emitters, to protect yourself from broken glass that you may come into contact with.
- Pulling the connection cable should not cause any tension to the flat base. Bending radius of connection cable: > 30 mm.
- The safety and functional reliability of the IR heating device are guaranteed only when using original accessories and spare parts from HP.
- After an emitter break, a dangerous voltage may be exposed to contact by the heating spiral.
- The reflector side should not be cleaned.

After installation, the bottom glasses of the IR emitter must be cleaned of any soiling or perspiration. See [Clean the fusing-lamp glasses on page 150](#).

Replace the fusing lamp

1. Turn the assembly upside down and unscrew the four screws of the exterior glass frame.

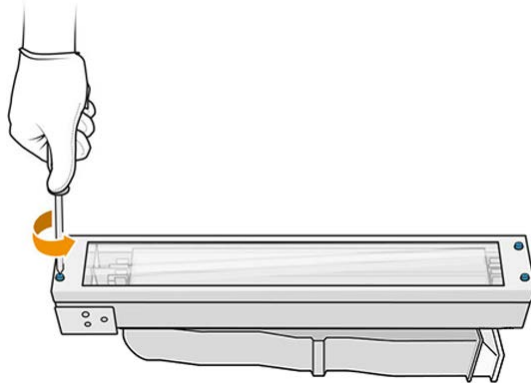

2. Carefully remove the frame of the exterior glass.

⚠ CAUTION: When you remove the frame, the glass may stick to it. Take care that the glass does not fall out of the frame as you pick it up.

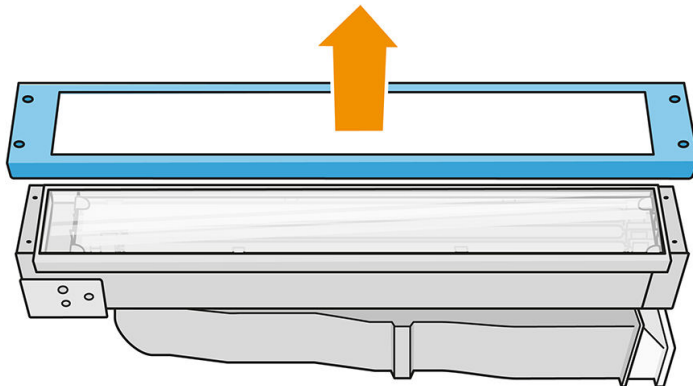

3. Remove the exterior glass.

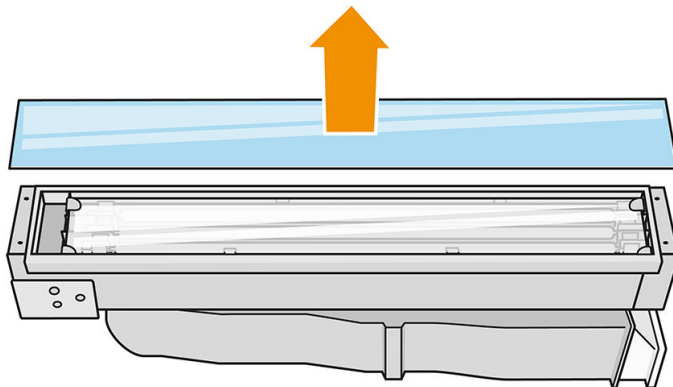

4. Open the metallic clip on one side, remove the fusing lamp, then do the same on the other side.

5. Insert the internal glass by pushing down the metallic clip.

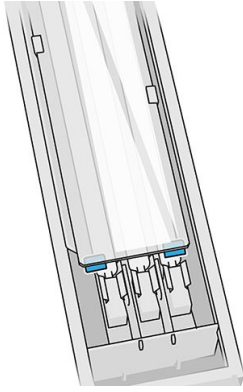

6. Add the frame with the bottom glass, securing it with four screws.

Reassemble the fusing-lamp module

- ▲ See [Reassemble the fusing-lamp module on page 154](#).

Finish the replacement

1. Close the top cover.
2. Tap **Finish**.
3. Turn on the printer.
4. At the front panel, tap , then **System tools** > **Printer reset counter** > **Fusing lamps replacement**.
5. Dispose of the old fusing lamp according to local regulations.

Processing station

Material

Material states

- **Reusable:** Material that can be reused
- **Waste material:** Used material that should not be reused
- **Mixed:** A mixture of new and used material, by default 20% new and 80% used
- **Fresh:** New material

Material cartridges

The material cartridges deposit the material in the build unit. See the material list for ordering information.

- The HP Jet Fusion 5200 accepts cartridges with a capacity of 30 or 300 liters.
- The HP Jet Fusion 5210 accepts the use of the refillable HP Material Loading Tank with a capacity of 300 liters.

The weight of the cartridge varies according to the material type. Special care must be taken to avoid personal injury when handling heavy cartridges.

If pressure is put on a cartridge while it is being vacuumed, and the connection is removed, material spills may happen. To avoid spills:

- Do not remove the handle while vacuuming.
- Never place anything heavy—more than 1 kg (2.2 lb)—on top of a cartridge.
- Take care not to drop a cartridge.
- Do not try to force the last of the material out of an almost-empty cartridge by pressing the bag inside the cartridge.

Replace a cartridge

A cartridge should be removed and replaced when it is empty or past its expiry date. An empty cartridge is indicated in the front panel and by the LED beside the cartridge.

⚠ CAUTION: Removing a cartridge before it is empty is not recommended. Cartridges are not designed for storing material after removing the seal, and storing an opened cartridge containing material can render the material unusable and cause safety hazards, such as a cloud of material if dropped. Depending on the material, it can be sensitive to temperature, humidity, or other factors. Using cartridges under uncontrolled conditions can affect the functionality of the equipment or severely damage it.

30 liter cartridge replacement

1. At the processing station's front panel, tap , then **Fresh material > Replace**.
2. Go to the cartridge that you intend to remove and hold it with one hand while disconnecting the cartridge connector, by pulling it gently away from the cartridge.
3. Remove the empty cartridge.
 - If the cartridge is not empty and you intend to use it later, make sure to close the front spout.
 - If it is empty, dispose of it according to local regulations.

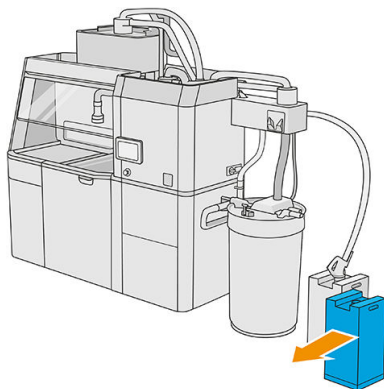

4. To prepare the new cartridge, tear off the square and fold it inside the handle as illustrated on the box.

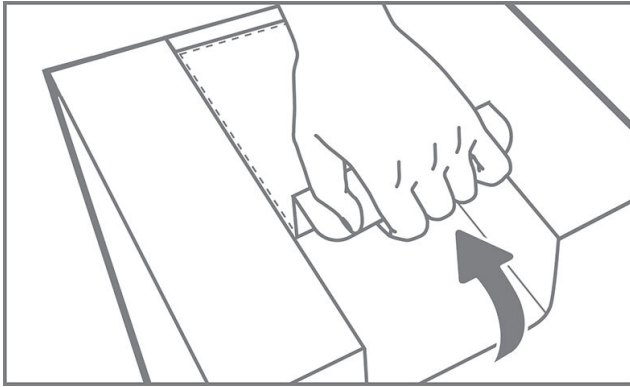

5. Remove the seal from the rear spout.

 **IMPORTANT:** The cartridge will not work unless you remove the seal.

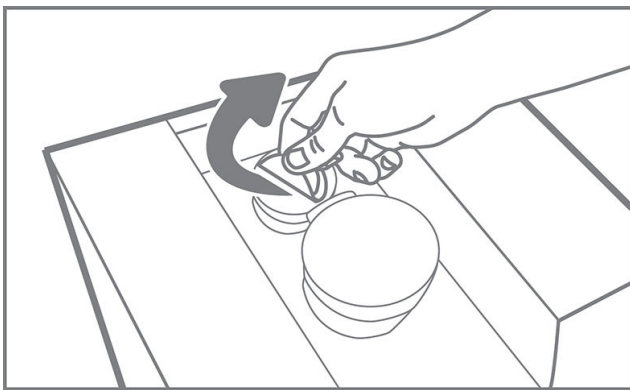

6. Put the new cartridge into its correct place next to the storage tank.

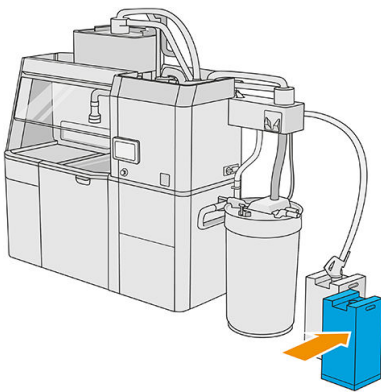

7. Open the front spout.

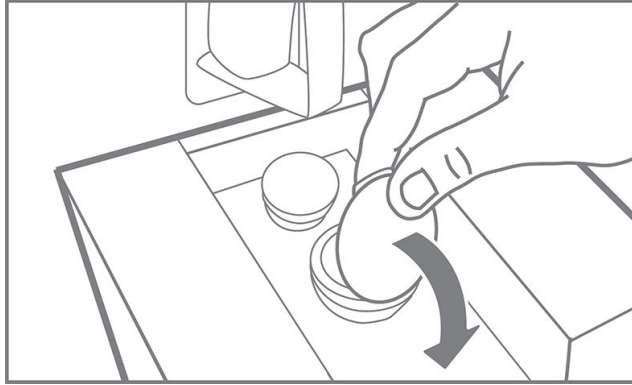

8. Remove the seal from the front spout.

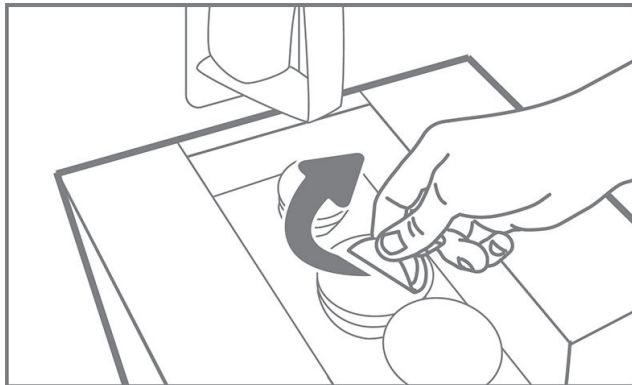

⚠ CAUTION: Once the seal has been removed, the cartridge should be used until it is empty, and not put into storage. Cartridges are not designed for storing material after removing the seal, and storing an opened cartridge containing material can render the material unusable and cause safety hazards, such as a cloud of material if dropped. Depending on the material, it can be sensitive to temperature, humidity, or other factors. Using cartridges under uncontrolled conditions can affect the functionality of the equipment or severely damage it.

9. Connect the cartridge connector to the cartridge.

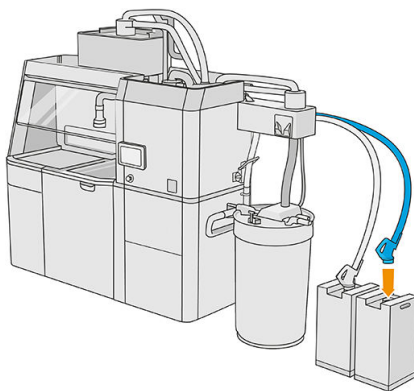

💡 TIP: If the new cartridge fails to work, follow the troubleshooting procedure below. The problem may be with the connector rather than the cartridge itself.

LEDs

- **White:** OK
- **Yellow:** Warning
- **Red:** Error, out of material

The processing station can continue filling the build unit without any cartridges for some time, depending on the material needed.

300 liter cartridge replacement

1. At the processing station's front panel, tap , then **Fresh material > Replace**.
2. Use a pallet jack to move the large material cartridges next to the external tank.

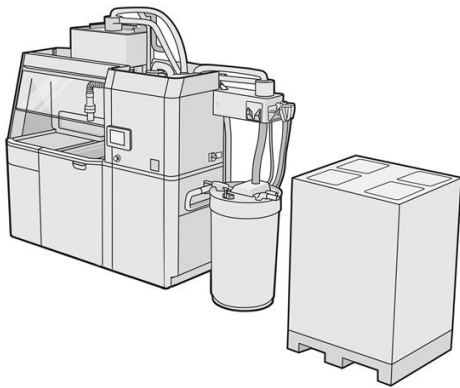

3. Remove the cardboards indicated on the packaging as 1 and 2.

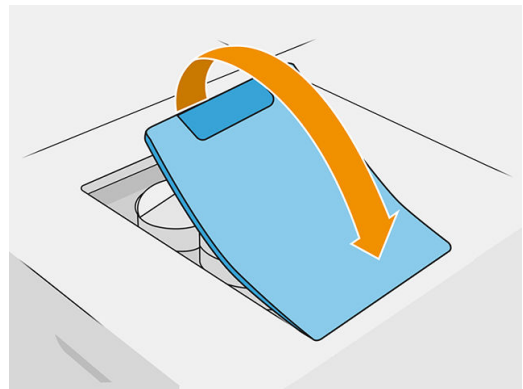
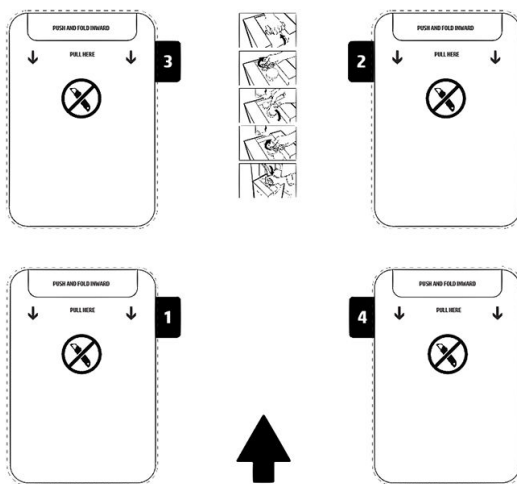

4. Remove the seal from the rear spout of slot 1.

 **IMPORTANT:** The cartridge will not work unless you remove the seal.

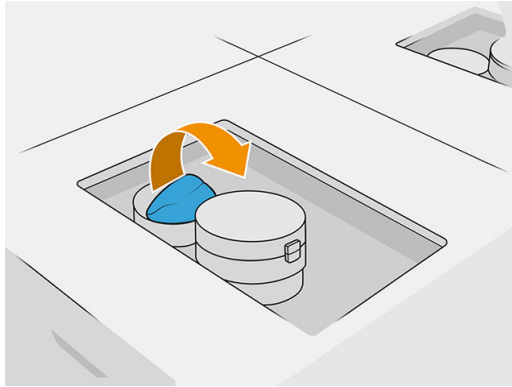

5. Open the front spout.



6. Remove the seal from the front spout.

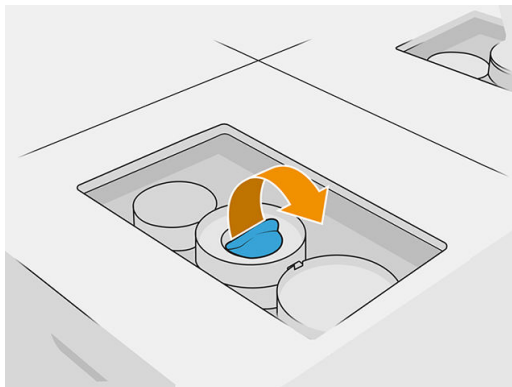

 **CAUTION:** Once the seal has been removed, the cartridge should be used until it is empty, and not put into storage. Cartridges are not designed for storing material after removing the seal, and storing an opened cartridge containing material can render the material unusable and cause safety hazards, such as a cloud of material if dropped. Depending on the material, it can be sensitive to temperature, humidity, or other factors. Using cartridges under uncontrolled conditions can affect the functionality of the equipment or severely damage it.

7. Repeat steps 4–6 on spout 2.

8. Connect the cartridge connectors to the cartridge 1 and 2. You are recommended to wear gloves and goggles.

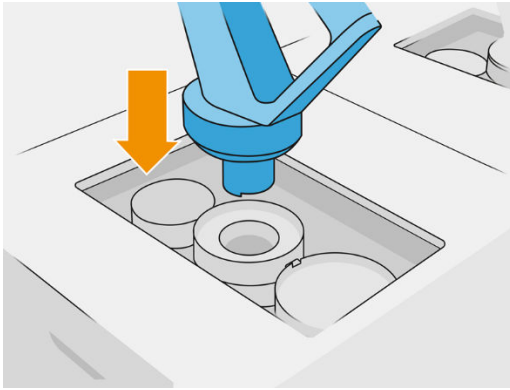

9. Tap **Finish and check** on the front panel.

300 liter cartridge: Swap the material connector

When running out of material on one connector, you can swap it for a full one. Number 1 can be replaced by 3 and 2 by 4.

1. At the processing station's front panel, tap , then **Fresh material > Replace**.
2. Disconnect the material cartridge connector from the used material supply.

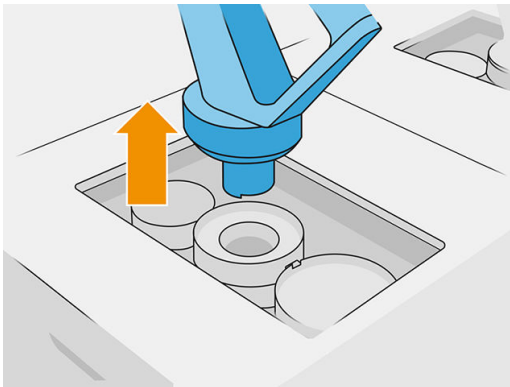

3. Remove the cardboard and seal from the rear and front spouts.

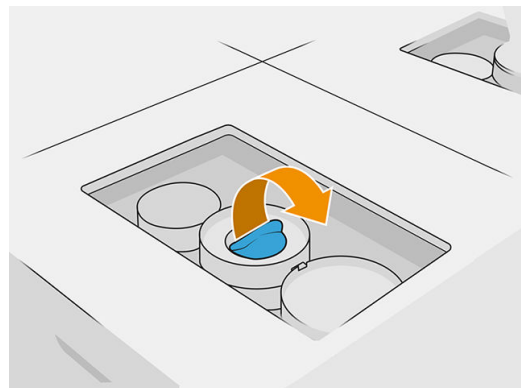

4. Connect the material cartridge connector to the new material cartridge.

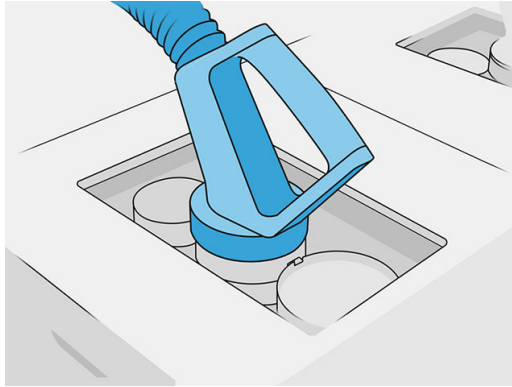

5. Tap **Finish and check** on the front panel.

Bulk material supply (5210 Pro only)

 **IMPORTANT:** Do not use material loading tanks with other material cartridges connected at the same time.

Ensure that any new material loading tank contains the same material type that is in use in the processing station.

1. At the processing station's front panel, tap , then **Fresh material > Replace**.
2. Disconnect the material loading tank connector from the lid, and hang it on the structure.
3. Remove the empty material loading tank to be replaced.

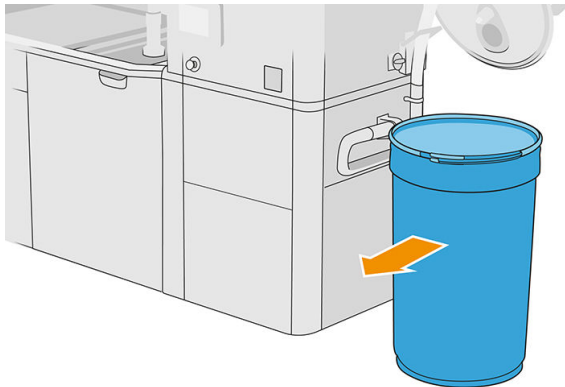



4. Use a lift trolley to move the full material loading tank next to the external tank.

 **NOTE:** If the material loading tank has been stored for some time before use, HP recommends using a drum rotator to rotate it in order to uncompact it. For this operation, the storage lid must be used (not the loading lid) and properly closed with the clamp. The number of turns to uncompact the material depends on the material and on the level of compaction; however, in general 90 seconds at 30 rpm should be enough. If you take no material from the material loading tank for some time, you may need to use the drum rotator again.

 **CAUTION:** If you use a drum rotator, take care that it does not rub against the base or the cover of the material loading tank while rotating.

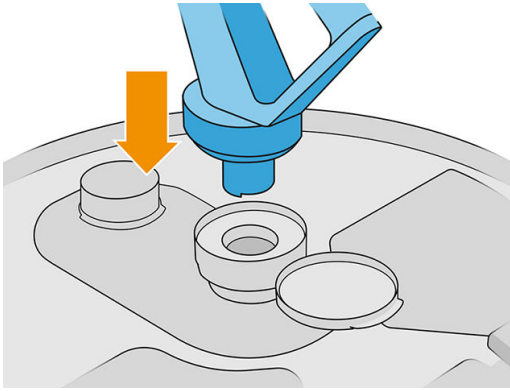
5. Connect the material loading tank connector to the lid.



 **NOTE:** HP recommends using tanks in the same order in which they were filled from the bulk material supply.

6. Connect the static earthing clamps from one material loading tank lid to the other.

 **NOTE:** If you are using only one material loading tank, connect it to the external tank lid.

The customer is responsible for tracking bulk material usage and material loading tank contents.

You should maintain logs that, at minimum, track the history of the bulk material received (part number, lot number, expiration date, and so on). In addition, each material loading tank requires identification of the bulk material details (part number, lot number, expiration, fill sequence) and any other relevant remarks (such as date of filling). The material loading tank details should be placed in a visible area.

Fill the material loading tanks from the bulk material supply

The recommended method is to create your own infrastructure to transfer the material according to the requirements of the material. Check the form in which the material supply arrives, and its requirements.

 **CAUTION:** It is important to transfer only material into the processing station. Your own infrastructure must protect against the suction of small parts into the processing station, which can cause safety hazards and malfunctions.

You can connect an material loading tank to the processing station: it is capable of transferring the material. At the front panel, tap , then **Fresh material > Offload**.

 **IMPORTANT:** Ensure that the material type in the bulk supply is the same as the material currently loaded in the processing station.

Ensure that the material loading tank does not contain any other material type.

If you want to change to a different type of material, first clean the inside of the tank with an explosion-protected vacuum cleaner (do not use cleaning products). Also clean the pipe thoroughly, removing all material.

1. Remove the clamp, the tap, and the rubber from the top of the processing station.

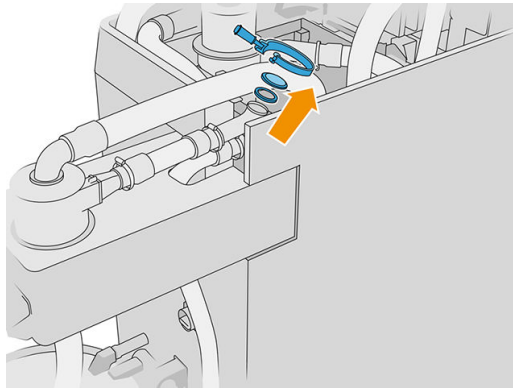

2. Connect the tube from the external equipment and close it with the clamp.

 **IMPORTANT:** Do not forget the rubber.

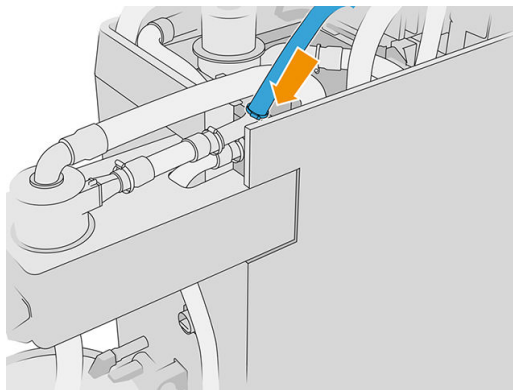

3. Use a multimeter to measure the continuity between the processing station structure and the external equipment structure. The measurement should be less than 100 Ω .

 **IMPORTANT:** The processing station and the external equipment should both be disconnected from the mains supply before the measurement.

4. If you have a material loading tank or overflow connected, remove it.
5. Place an empty material loading tank and close the lid.

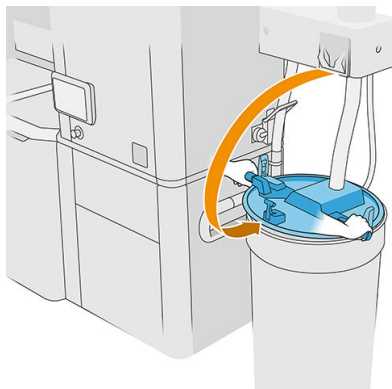

 **TIP:** When closing the lid, if you find that it interferes with one of the blades inside the material loading tank, rotate the material loading tank on its axis by about 60° and try again; do not turn the lid.

6. Tap **Continue** on the front panel to fill the material loading tank. The process will stop automatically once the material loading tank is full.

7. If you want to fill more material loading tanks, declare that in the front panel and replace the full material loading tank by an empty one.
8. At the end, make sure the part of the tube coming from the external equipment and the bulk supply is not in contact with the material and tap **Continue** on the front panel. Processing will extract the material remaining in the tube.
9. Disconnect the tube from the top of the processing station and put back the rubber, tap, and clamp.
10. Place the external tank.

It is the responsibility of the owner to maintain records of material batch information and usage.

- Identify each tank with product number, batch number, and warranty/expiration date. Do not use materials after their expiration date has passed.
- In order to retain traceability of fresh material, ensure that the material loading tank is empty of material from previous batches before refilling it.
- If you also need to retain traceability of recycled material, you will need to empty all the build units and processing stations that will work with the new material batch, using the clean workflow, and install an empty tank when starting. Otherwise the recycled material will have a random composition of material coming from previous batches.
- Bulk supply must be stored and handled following the HP guidelines applicable to that specific material.
- Not following these traceability practices can invalidate claims against the warranty of the equipment or consumables.

Material cartridge troubleshooting

1. Check that the cartridge is designed for your printer.
2. Use the correct procedure to change cartridges, through the front panel.
3. Check that there is no obstruction in the cartridge connector.
4. Check that the cartridge is correctly oriented (compare with another cartridge).
5. Ensure that you have inserted the connector correctly and fully. You should hear a click.
6. If the problem still remains, call your support representative.

Maintain the cartridges

Before use, the material must acclimatize to the environmental conditions of the room for at least two days.

During the normal lifetime of a cartridge, no specific maintenance is required. However, to maintain the highest quality, replace a cartridge when it reaches its expiration date. An alert notifies you when any cartridge reaches its expiration date.

Store the cartridges

Cartridges should be stored according to cartridge specifications. Before use, a cartridge should be kept at processing-station environmental conditions for at least 2 days.

⚠ CAUTION: HP recommends storing only sealed cartridges. Cartridges are not designed for storing material after removing the seal, and storing an opened cartridge containing material can render the material unusable and cause safety hazards, such as a cloud of material if dropped. Depending on the material, it can be sensitive to temperature, humidity, or other factors. Using cartridges under uncontrolled conditions can affect the functionality of the equipment or severely damage it.

Storage in the build unit

⚠ CAUTION: HP recommends not storing material in the build unit for more than one or two weeks.

Storage and external tanks

When unpacking, all reused material is stored in the storage tank until it is full. After that, the reused material is stored in the external tank. The mixer is fed with fresh material from the material cartridge and reused material from the storage tank.

If the storage tank is empty when you need to fill the build unit with material for printing, the system will fill it automatically from the external tank. If you want to fill the storage tank in advance for future jobs, you can do it automatically from the front panel by tapping **Reclaimed material > Storage tank > Fill automatic**, or manually by tapping **Reclaimed material > Storage tank > Fill manual**. You will be asked to follow these steps:

1. Unlatch and open the lid.

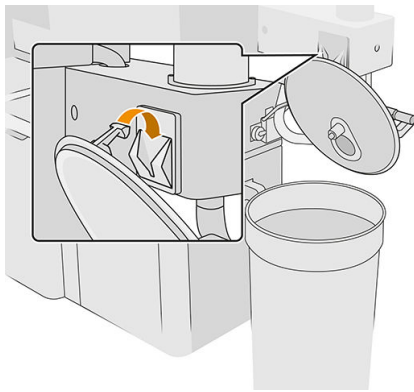

2. Connect the external tank collector and pipe. You are recommended to wear gloves and goggles.

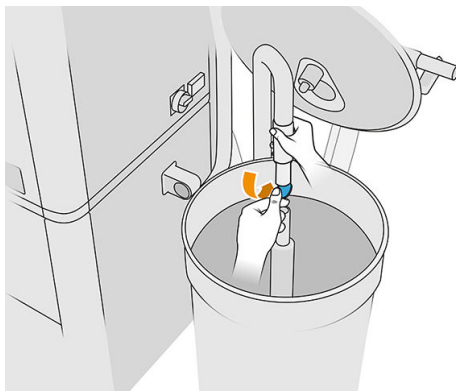

📝 NOTE: If you leave the pipe in one position, it will consume all the material in that area, while there is still material elsewhere in the tank. You should therefore move the pipe around in the tank to access all the available material.

📝 NOTE: You can insert the pipe with the vacuum switched off, if you like.

3. The process ends when the storage tank is full or the external tank is empty, whichever happens first.
4. Unplug the external tank collector.
5. Close the lid and latches.

If you are loading material into the build unit, but there is not enough reused material in the storage tank to process the job as specified, the front panel will ask you to fill it from the external tank. In this case, only the reused material needed to load the build unit will be transferred.

If both tanks are full, or there is not enough space for unpacking, the processing station will ask you to replace the external tank when the build unit is inserted.

 **CAUTION:** Use HP-certified external tanks only. The use of third-party external tanks can cause safety risks, material leakages, and malfunctions in the processing station; and may affect your system warranty.

 **NOTE:** The processing station may ask you to check the material quantity in the storage tank. To do so, check the ruler in the tank, and follow the steps in the front panel.

Replacement

- ▲ See [Replace the external tank on page 218](#).

How to recycle supplies

NOTICE: Parts and waste generated during the printing process should be disposed of in compliance with federal, state, and local regulations. Consult your local authorities to determine the correct manner in which to dispose of wastes. It may be possible to recycle printed parts for non-3D uses. Where appropriate it is recommended that the parts be marked with the applicable plastic marking code according to ISO 11469 to encourage recycling.

HP provides many free and convenient ways to recycle your used HP cartridges and other supplies. For information about these HP programs, see <http://www.hp.com/recycle/>.

The following supplies for your printer can be recycled through the HP supplies recycling program:

- HP printheads

High-volume 3-liter cartridges should be disposed of by following the instructions on the cartridge packaging. The agent bag should be removed and disposed of in compliance with federal, state, and local regulations. The other cartridge parts (plastic retainer and packaging box) can be recycled through commonly available recycling programs.

Dispose of the following supplies in compliance with federal, state, and local regulations:

- Material cartridges

For further information about recycling cartridges, see <http://www.hp.com/go/jetfusion3Dprocessingstation/recycle>.

- Printhead cleaning roll
- Lamps
- Filters

HP recommends that you wear gloves while handling printer supplies.

7 Design and printing guidelines

- [Introduction](#)
- [File preparation](#)
 - [Tessellation](#)
- [Minimum specification for parts](#)
- [Other considerations](#)
 - [Contraction coefficient](#)
 - [Orientation](#)
 - [Positioning of parts in the build chamber](#)
 - [Repeatability](#)
 - [Distance between parts in the build chamber](#)
 - [Printing a part for final production](#)
 - [Orientation flowcharts](#)
 - [Generating a sinter box](#)
 - [Fast cooling considerations](#)

Introduction

A print job can be created in either of the following ways:

- By using the HP SmartStream 3D Build Manager

 **NOTE:** HP SmartStream 3D Build Manager supports STL and 3MF files.

- By using third-party software

The software creates slices that the printer can convert to layers in order to prepare the job. This preparation process may take from 15 minutes to 2 hours depending on the complexity of the job. It can be done while printing other jobs. Once ready, you can select the job to be printed from the job queue on the printer's front panel. If an error occurs while processing, a message appears on the front panel, and the printer cancels the job. To retry, you have to resubmit the job.

The rest of this chapter may help you to avoid such errors.

File preparation

Tessellation

Before sending a job to a 3D printer, the model to be printed needs to be tessellated. That means that its geometry needs to be converted into triangles, which are used by the printer to create layers. It is very important to pay attention to this step: if not done correctly, it can cause problems such as inaccuracy or slow processing.

Standard formats in the additive manufacturing industry include 3MF (with more information about the model) and STL.

A normal file size for a model is about 1–30 MB, but the size depends on the type of software that created it, the number of triangles, the number and level of details, and so on.

When exporting to STL in a CAD package, you are often required to introduce some parameters such as angle tolerance and deviation chord height. These parameters define the resolution and file size of the part. The following tips may help you to export with the best surface to file size ratio.

Solid Designer settings

Save as STL, click **Options**, and check the ASCII option. The recommended values for the Distance and Angle box are 0.05 and 1.

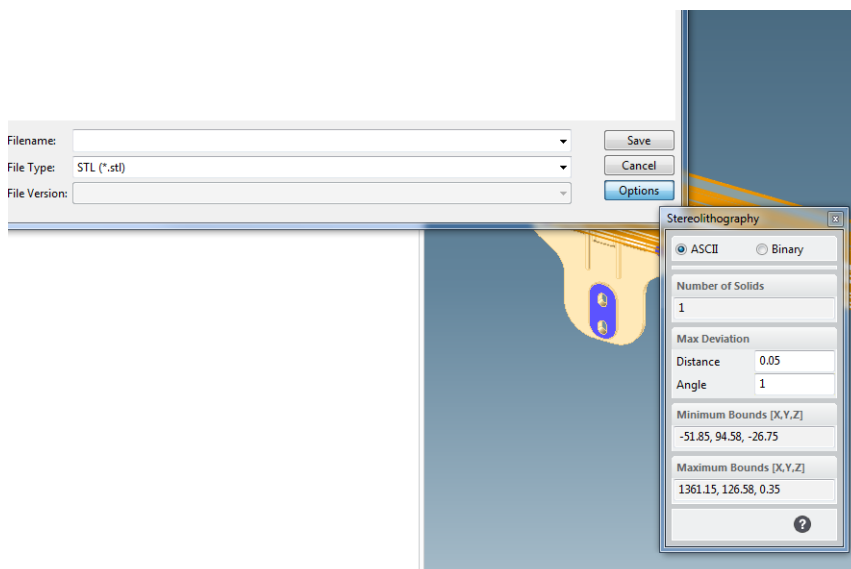

SolidWorks settings

1. Click **File > Save As**.
2. Select **STL (*.stl)** as the file type.
3. Click **Options**.
4. Choose the **Binary** option. Binary files are smaller than ASCII files for the same tessellation.
5. Choose **Custom** resolution.
6. Set the deviation tolerance to 0.05 mm.
7. Set the angle tolerance to 1°.

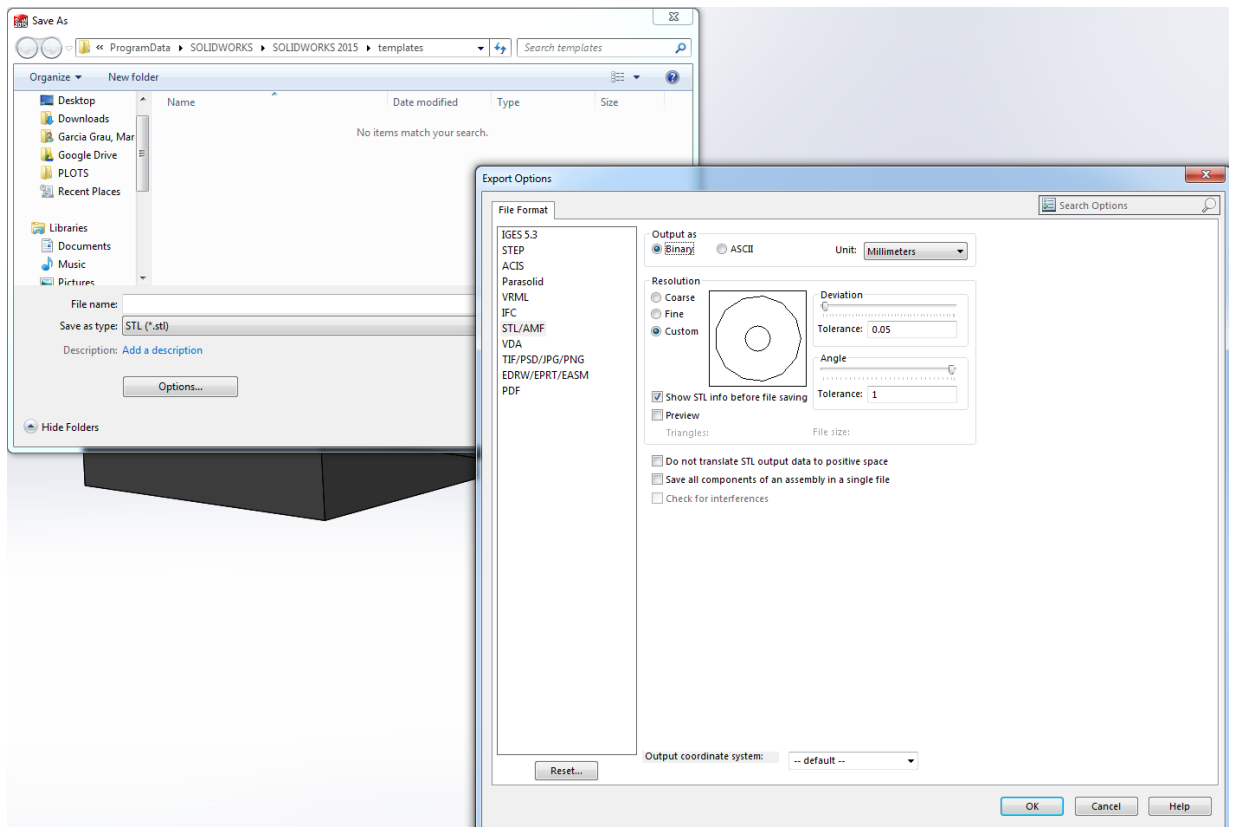

Rhinoceros settings

1. Click **File > Save As**.
2. Select **STL (*.stl)** as the file type.
3. Click **File Name > Save**.
4. Select **Binary**.
5. Select **Detail Controls** from the Mesh Options.
6. Set the maximum angle to 1, the maximum aspect ratio to 6, and the minimum edge length to 0.05.

STL problems

- Too many or too few triangles

Too many triangles are difficult to process and, when a certain size is reached, the extra triangles do not provide any further accuracy. For this reason, an excess of triangles could increase processing time for no benefit.

Triangulation of a surface causes faceting of the 3D model. The parameters used to output an STL model affect how much faceting occurs.

Example of tessellation

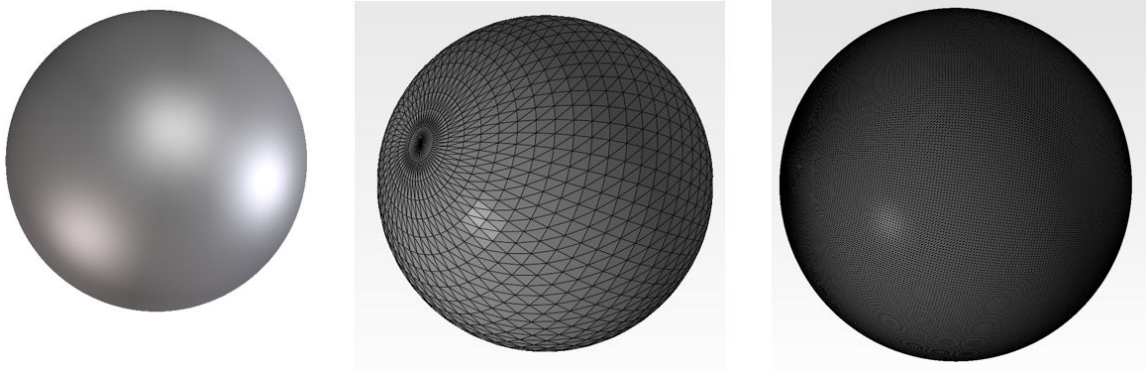

- Holes in triangles

STL models commonly suffer from surfaces that are not joined to their neighbors, and missing surfaces.

Repairing STL files

STL-repairing software

- Magics – Materialise
- Netfabb
- HP SmartStream 3D Build Manager

Common errors in STL files

- Triangles not joined

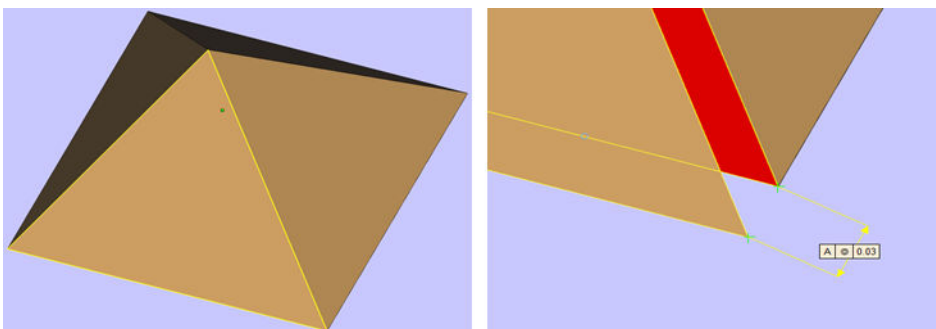

- Overlapping triangles

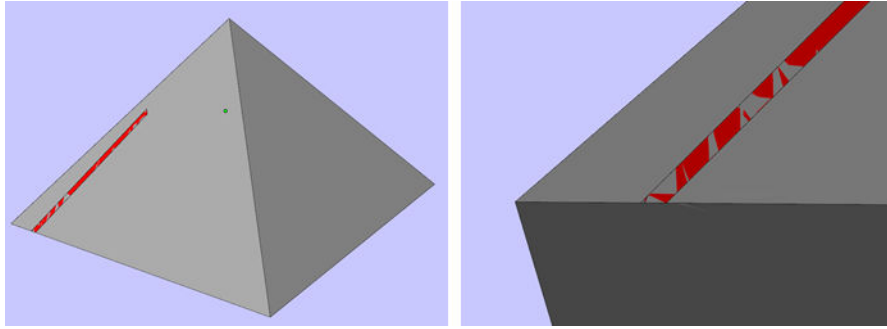

- Holes in parts

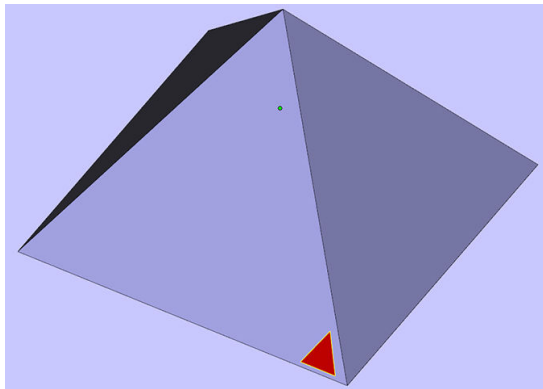

- Flipped-direction triangles

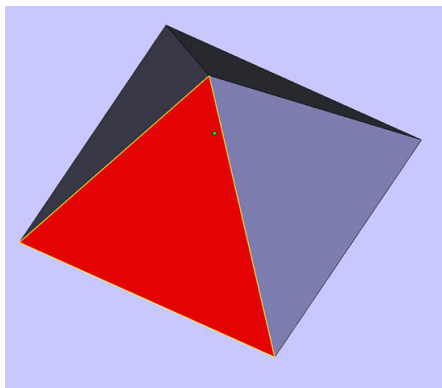

- Tiny shells

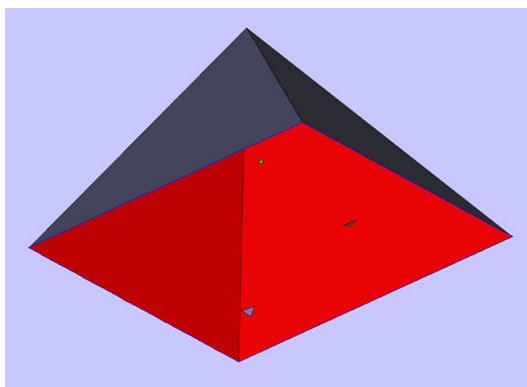

Minimum specification for parts

There are some specifications to bear in mind in order to avoid issues in parts, and to achieve the best quality. The minimum printable features in planes X, Y, and Z are as follows:

Minimum hole diameter at 1 mm thickness	0.5 mm
Minimum shaft diameter at 10 mm height	0.5 mm
Minimum printable font size for embossed or debossed letters or numbers	6 pt
Minimum clearance at 1 mm thickness	0.5 mm
Minimum slit between walls	0.5 mm

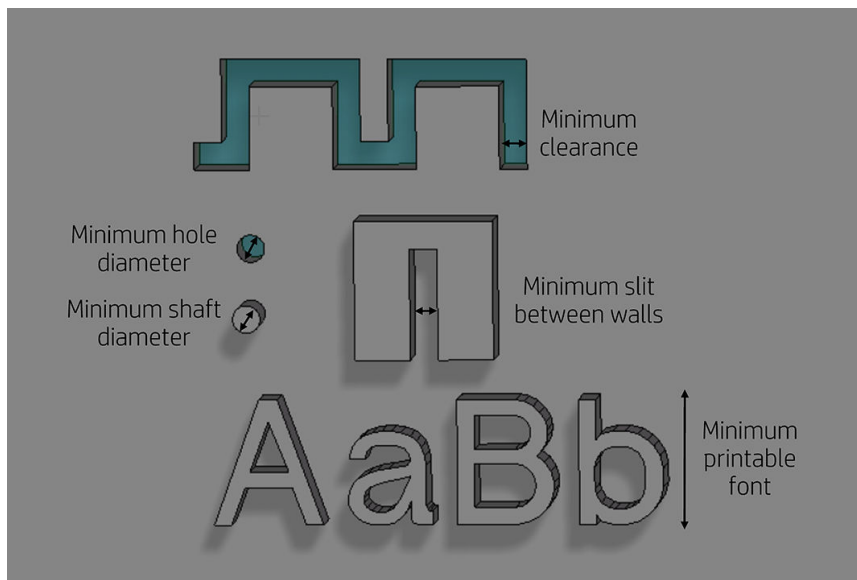

- **Engraving.** Multi Jet Fusion technology allows you to print letters and drawings with a very high resolution and definition.

For the best possible output, any text, number, or drawing included in a part is recommended to have at least 1 mm of depth or height.

The best orientation for embossing letters is to place them upside down in the build chamber, while for debossing letters it is better to place them face up to achieve the best resolution.

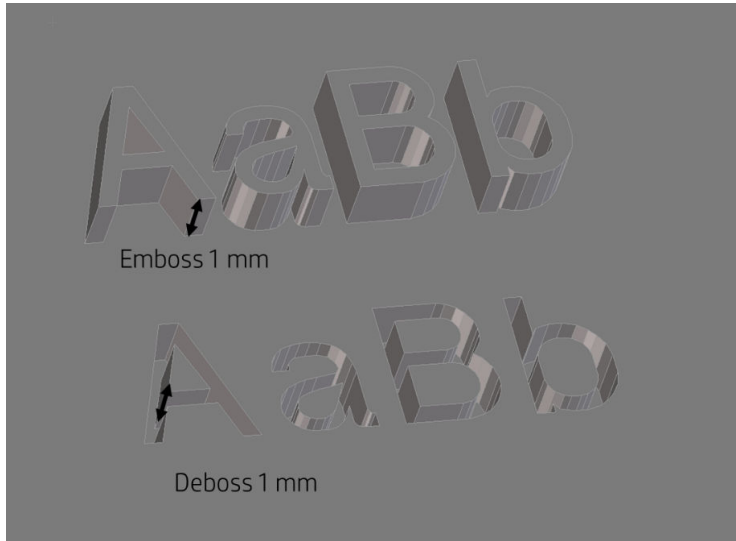

- The **dimensional accuracy** that can be achieved by HP Jet Fusion 3D is ± 0.2 mm up to 100 mm and 0.2% above that value, measured after sand blasting.
- **Solid part or structural fill.** Multi Jet Fusion allows you to print topology-optimized, generative designs or even small lattice structures. This kind of design helps to reduce the weight of the part and the quantity of material used, which not only reduces the cost of the part but also helps to reduce the operating cost in applications that are very weight-sensitive.

The minimum gap recommended in a lattice structure to ensure that all the material inside the part can be removed is 1 mm.

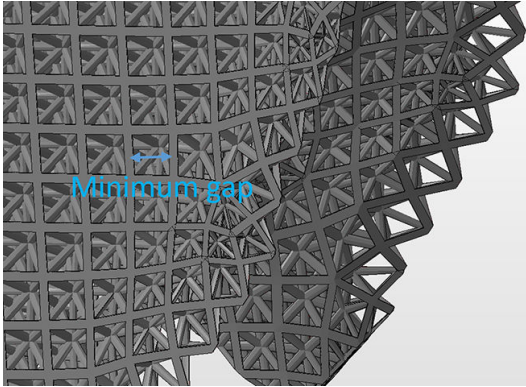

- When printing a **cantilever**, the minimum wall thickness depends on the aspect ratio, which is the length divided by the width.

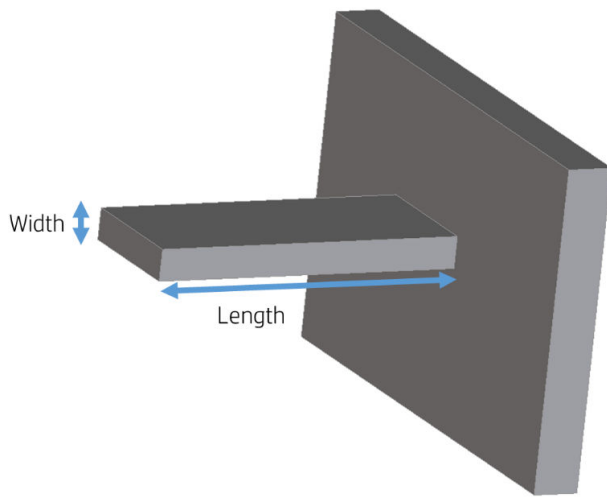

$$\text{Aspect ratio} = \text{Length}/\text{Width}$$

For a cantilever with a width less than 1 mm, the aspect ratio should be less than 1. There are no specific recommendations for widths greater than 1 mm.

- In general, the minimum recommended **wall thickness** is 0.3 mm for short walls oriented in the XY plane, and 0.4 mm for short walls oriented in the Z plane.

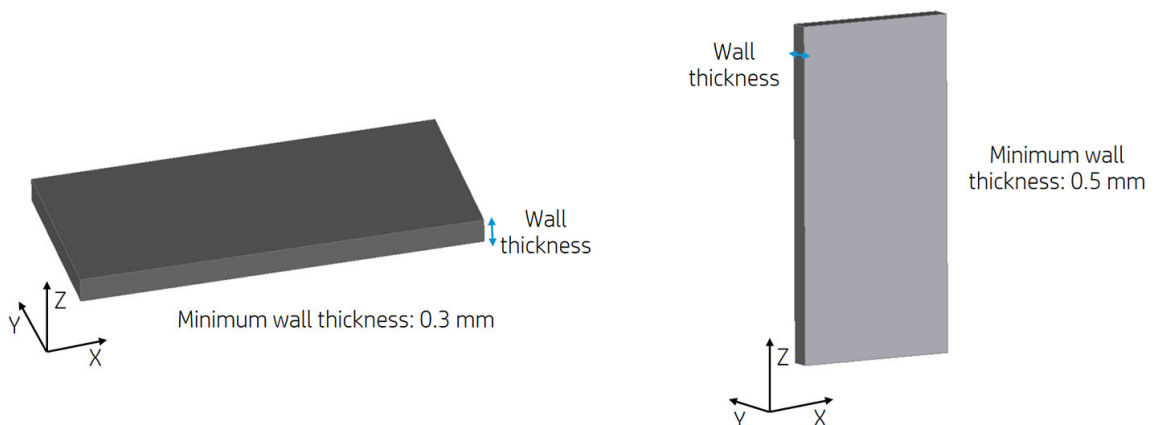

For parts with a high aspect ratio, you are recommended to increase the wall thickness, or add ribs or fillets to reinforce the part.

Very thick walls can accumulate heat and cause spot shrinkage in dense areas with an accumulation of material.

 **TIP:** Hollow out the part as much as possible, saving agent and powder, and reducing sink marks.

- **Minimum gap** between parts to be assembled after printing. Sometimes a pair of printed parts need to fit together for the final application. In these cases, you are recommended to have gaps of at least 0.4 mm (± 0.2 mm of tolerance of each part) between the interface areas that should fit together, in order to ensure correct assembly.

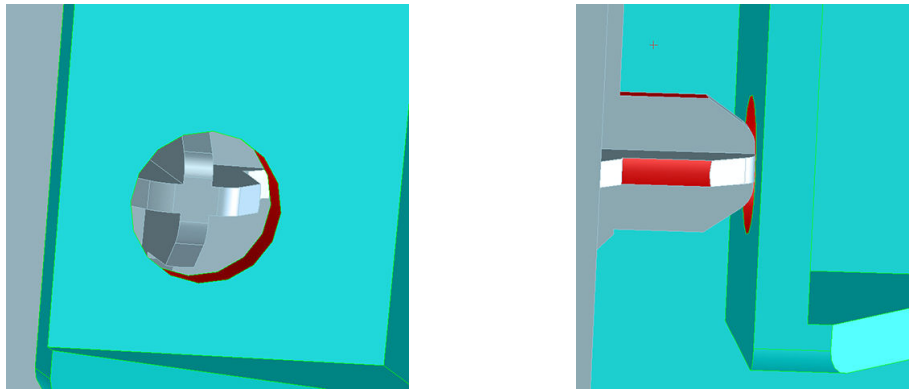

- **Minimum spacing and clearance** between parts printed as assemblies. Assembly parts that are printed together should have a minimum clearance of 0.7 mm. Parts with very thick walls above 50 mm should have a higher gap in order to ensure proper performance.

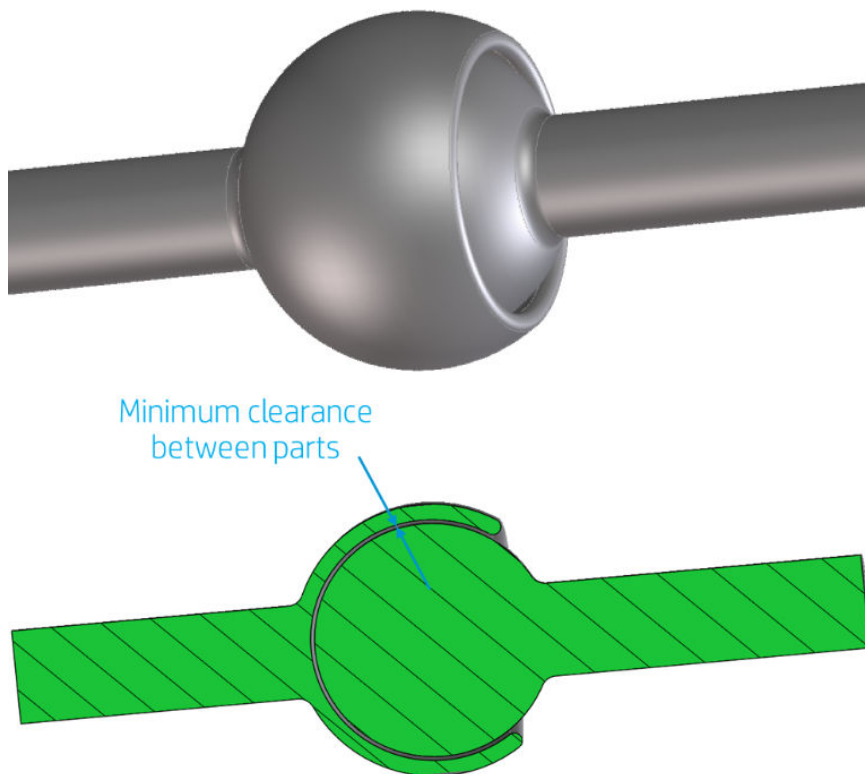

- **Hollow closed geometries.** Multi Jet Fusion is a process in which the parts are built by selectively fusing the desired areas of a material-based layer. If the parts printed are hollow, drain holes need to be added to the design to remove the material. The minimum recommended diameter of the holes is 2 mm. You are recommended to include at least two holes.

- **Glue lines.** Parts larger than the maximum build size can be printed with Multi Jet Fusion by splitting them into different parts. They can then be joined together by glueing, welding, or by pin inserts.

If you plan to glue parts together, you are recommended to include interlocking features such as those shown in the pictures below: as a guide to position the parts, to help them to bond together, and to facilitate the glueing process. Remember to leave an additional space of 0.1–0.2 mm between parts for the glue, in addition to the minimum spacing between parts printed as assemblies (see above).



- **Ducts.** To remove material from narrow ducts, consider designing and printing a strip or a chain through the duct. When the parts have been printed, you can pull out the chain to dislodge most of the material. Any remaining material can be removed by the normal cleaning process.



8 Load material into the build unit

- [Loading procedure](#)
- [Change to a different type of material](#)

Loading procedure

1. Ensure that the build unit is located on the processing station.
2. Ensure that the build unit printing platform is clean.
3. If you want to change the mix ratio, HP recommends cleaning the build unit first. See [Empty the material from the build unit on page 97](#).

 **NOTE:** If you do not clean the build unit, it will contain some remaining material with the previous mix ratio. In fact, some of the previous material may remain even after cleaning, so you may prefer to use a different build unit. Check the material compatibility specifications.

The default and recommended mix ratio for HP and Certified Polyamide 12 material is 20% fresh and 80% reused; for HP and Certified Polyamide 11 it is 30% fresh and 70% reused. In some exceptional cases you may want to change this ratio; for example, when using the processing station for the first time you may need to use 100% fresh material.

4. If you want to change to a different type of material, you should first clean and purge the processing station. See [Purge the processing station on page 95](#). Then see [Change to a different type of material on page 93](#).

 **NOTE:** If you do not intend to change the type of material, you may sometimes decide to clean the processing station without purging it, perhaps because you think there is a problem with the particular material that you have been using. See [Clean the processing station on page 207](#).

 **CAUTION:** A small amount of material may remain after cleaning. If your new material cannot tolerate any contamination at all, you should use a different processing station.

5. Ensure that the material cartridges are loaded.
6. At the front panel, tap **Build unit > Load**.
7. Clean the sieve when requested by the front panel. See [Clean the sieve on page 203](#).
8. Clean the loading nozzle sensor. See [Clean the loading nozzle sensor on page 204](#).
9. Ensure that the material loading inlet is clean.
10. Open the lid of the material loading inlet of the build unit.

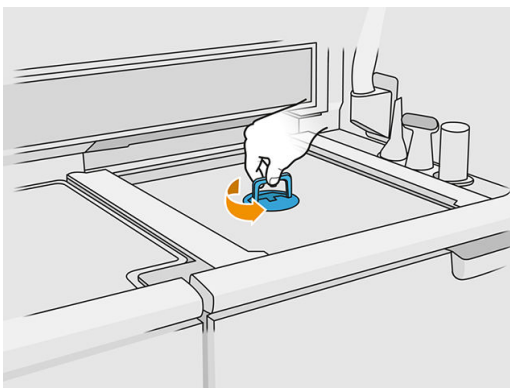

- Attach the material loading nozzle.

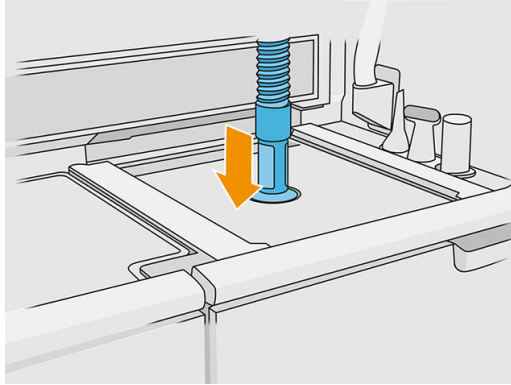

- Define the height by scrolling up and down the right bar. You can change the mix ratio if required.

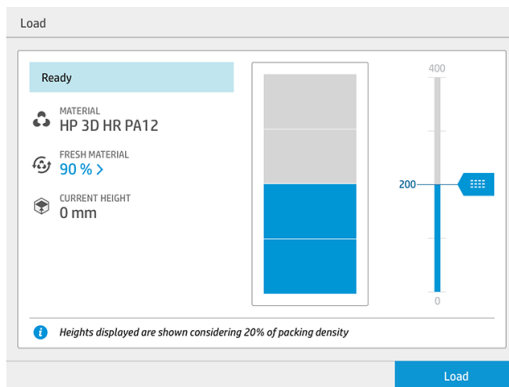

The loading time depends on the mix ratio used and the quantity to load; here are some approximate examples:

Material	Mix ratio	Estimated loading time (min)	
		Full print chamber	Half print chamber
HP 3D HR PA12	80% R – 20% F	40	23
HP 3D HR PA11	70% R – 30% F	45	26
TPU BASF	80% R – 20% F	75	40

 **NOTE:** The percentage full assumes a 20% packing density.

- Tap **Load** to continue.

- Tap **Start**.

 **NOTE:** To fill the build unit completely with a mix ratio of 80% recycled, 20% fresh, you may need to do it in two steps.

- The supply container of the unit is filled. Wait for front panel to report that it has been successfully loaded.

16. Detach the material loading nozzle and leave it in parking position.

 **NOTE:** If the loading nozzle is not correctly parked, there could be a material spillage while the processing station is idle.

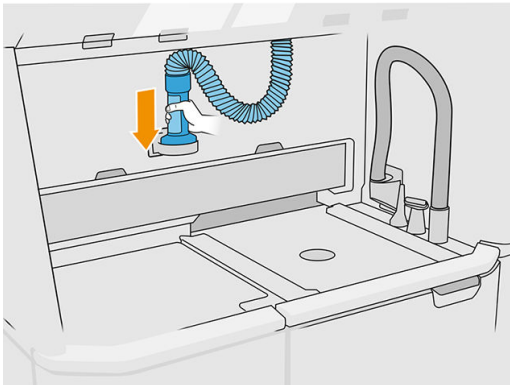

17. Close the material loading inlet.

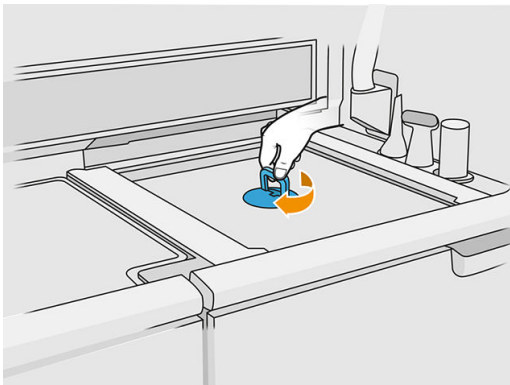

18. Extract the build unit from the processing station by pulling the handle, put the safety lid on top of the build unit, and move it to the printer.

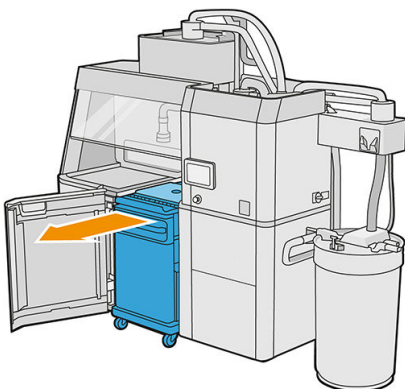

19. Open the printer door.



20. Remove the lid of the build unit.

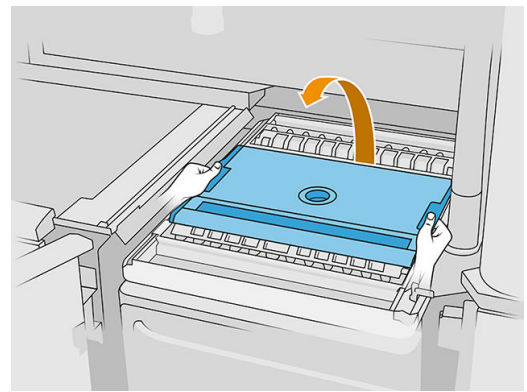
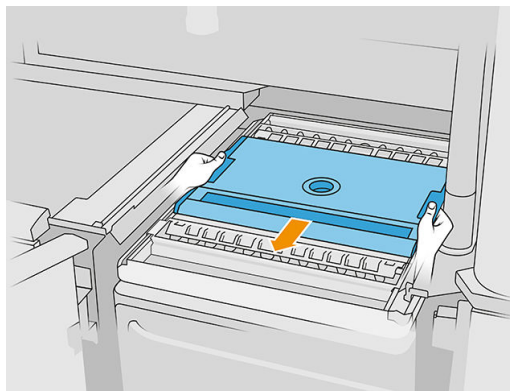

21. Insert the build unit by pushing the handles.
22. Close the printer door.

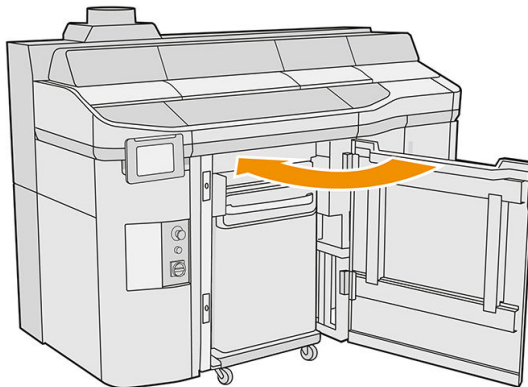

Change to a different type of material

The processing station stores and moves the material from the cartridges to the build unit. To completely remove all material particles from the loading path may be difficult. Therefore, depending on the compatibility of the materials, when changing from one material to another some special procedures may be needed. Check the compatibility chart on the webpage and follow the procedures below depending on the compatibility grade.

Download the material package from the HP webpage to a USB flash drive, connect it to the processing station, and then to the printer. At the processing station's front panel, tap , then **Settings > Change material**.

Grade 1: Light cleaning

Perform the following operations:

- [Check and clean the interior of the build unit on page 102](#)
- [Clean the processing station on page 207](#)
- Daily printer maintenance: see [Printer maintenance on page 126](#)

Grade 2: Deep cleaning and material purge

Perform the following operations:

- [Empty the material from the build unit on page 97](#)
- [Check and clean the interior of the build unit on page 102](#)
- [Clean the processing station on page 207](#)
- [Purge the processing station on page 95](#)



NOTE: You will need 30 liters of the new material (15 liters from each of the supplier connectors), to be used for purging.

For the printer, follow these steps:

1. Turn off the printer (see [Turn the printer on and off on page 33](#)).
2. [Clean the print zone, carriage, and housing structure on page 128](#).
3. [Clean the inside of the carriage on page 143](#).
4. [Clean the service-station caps on page 145](#).
5. [Clean the top-enclosure fan filters on page 146](#).
6. [Clean the print-zone window on page 162](#).
7. [Clean the bottom glass of the heating lamps on page 155](#).
8. [Clean the front bar on page 148](#).
9. [Clean the scan-axis wipers on page 142](#).
10. [Clean the bottom of the carriage and of the fusing lamps on page 133](#).
11. [Clean the fusing-lamp glasses on page 150](#).
12. [Clean the recoating roller and recoating plates on page 138](#).
13. [Clean the spittoon on page 131](#).
14. [Clean the thermal camera glass on page 134](#).
15. Turn on the printer (see [Turn the printer on and off on page 33](#)).
16. Perform diagnostics:
 - a. Calibrate the cooling system.
 - b. Finish checking/cleaning the spittoon.
17. [Clean the exterior of the printer on page 137](#).

Grade 3: Full deep clean

Contact your service representative for more information.

Purge the processing station

The processing station should be cleaned and purged before changing to a different type of material.

 **IMPORTANT:** The processing station should always be cleaned before purging. See [Clean the processing station on page 207](#).

IMPORTANT: If the system is switched off in the middle of the process, the process will need to be started again (cleaning included), and more fresh material will be needed.

 **CAUTION:** It is important to keep the purge tool in the indicated position during the whole process. In case of system error, do not disconnect the hoses; restart the processing station and restart the process, or start an unpacking process to ensure that the material left in the hoses is properly cleaned. If it is not possible to do either of these things, remove the tool from its position, keeping it horizontal to avoid possible material spillages.

1. At the front panel, tap , then **Material management > Purge processing station > Purge with fresh material**.
2. Replace the external tank by a new one, which will be used for waste material.
3. Put in place the new material cartridges containing the material that you want to use.
4. Take the purge tool from the drawer and place it on the side of the working area.

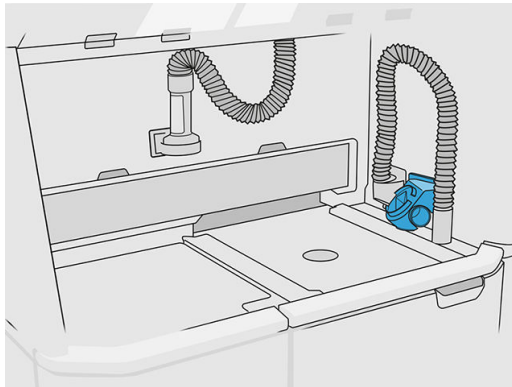

5. Connect the material loading nozzle to the reusable material collector with the purge tool.

 **CAUTION:** Ensure that the hoses are connected properly. The loading nozzle should be connected to the top and the material collector to the side.

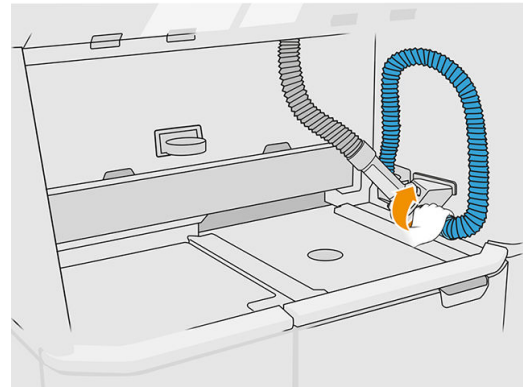
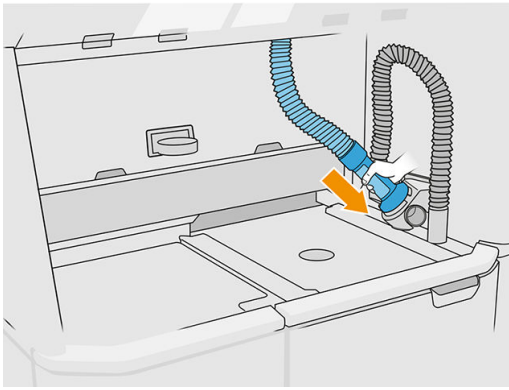

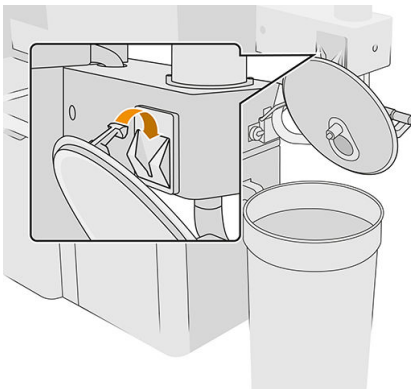

6. Tap **Continue**.
7. Unlatch and open the external tank lid.

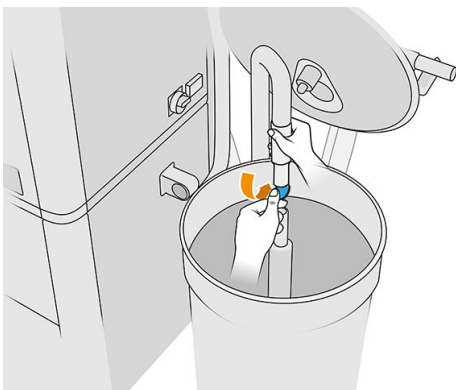

8. Connect the external tank collector and pipe. You are recommended to wear gloves and goggles.



 **NOTE:** The pipe sucks up material in its immediate vicinity. If you leave it in one position, it will consume all the material in that area, while there is still material elsewhere in the tank. You should therefore move the pipe around in the tank to access all the available material.

 **NOTE:** You can insert the pipe with the vacuum switched off, if you like.

9. Start the process from the front panel to extract the material from the external tank.
10. Confirm that all the material has been removed from the external tank.
11. Tap **Continue**.

12. Disconnect the material cartridge connectors.

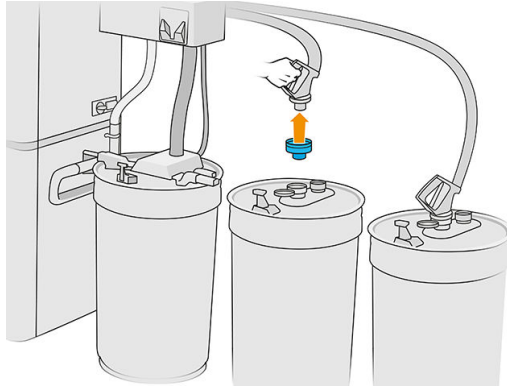

13. Tap **Continue**, then **Finish**.
14. Dispose of the material from the external tank according to local laws.
15. Clean the external tank with an explosion-protected vacuum cleaner.
16. Connect the material cartridges that you intend to use.



NOTE: After purging the processing station, you must configure the material to be used. Tap , then **Settings**.

Empty the material from the build unit

1. Insert the build unit into the processing station with no job inside it.
2. Clean the surface of the build unit, if you have not already done so. See [Clean the surface of the build unit on page 221](#).
3. At the front panel, tap **Build unit** > **Clean**.
4. Remove both vane feeders.

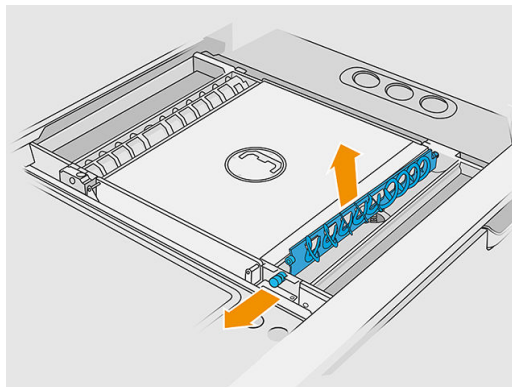

5. Follow the front panel instructions to vacuum the material inside the build unit.

6. Connect the material collector to the front material lifter, and tap **Start** on the front panel.

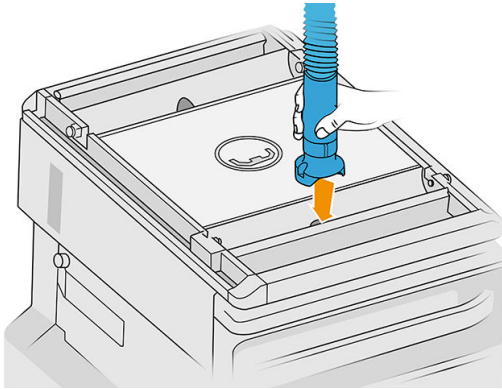

7. Repeat the same process with the rear material lifter.
8. Repeat again with the front material lifter until there is no material left inside.
9. Vacuum the build-unit printing platform with the reusable material collector.
10. Vacuum the front overflow tray.

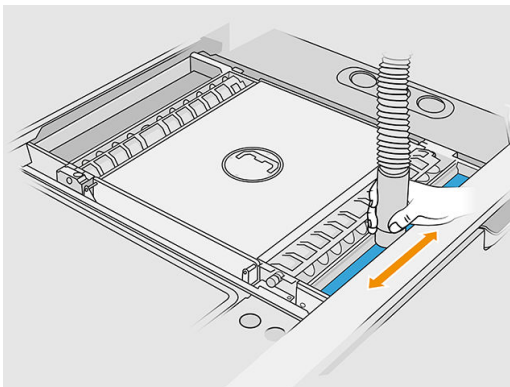

11. Vacuum the area below the cap of the build unit's loading inlet.

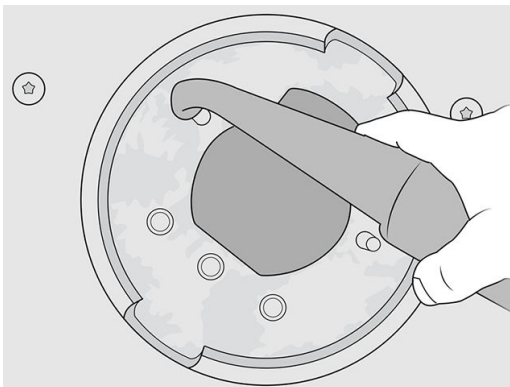

12. Vacuum the feed trays, making sure there is no material left.
13. Vacuum the other overflow trays.

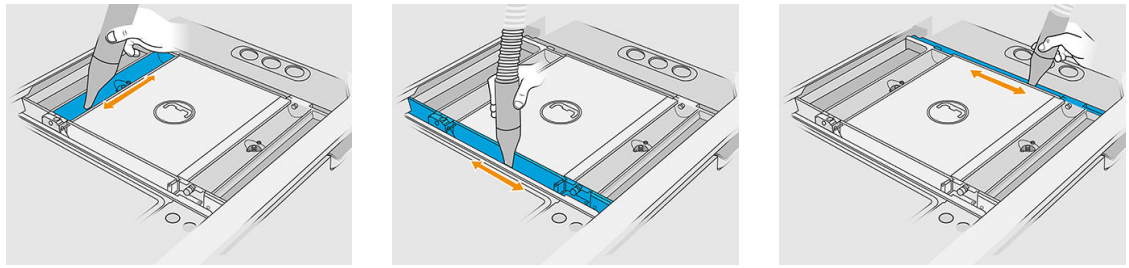

14. Attach the wide nozzle to the reusable material collector.
15. Vacuum the build unit platform.

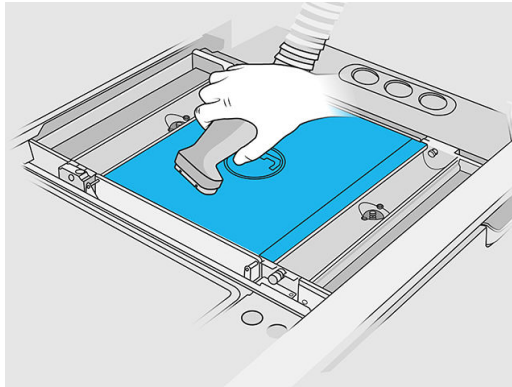

16. Go to the front panel and move down the platform of the build unit by 350 mm.
17. Remove the build unit from the processing station.
18. Manually remove the screw on top of each material lifter, and remove both material lifters.



19. Vacuum both material lifters with a soft-brush nozzle.

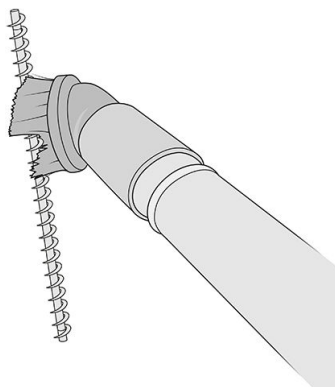

20. Clean the material lifter duct with a hand-held low-scratch tube brush.
21. Locate the material lid and remove the two Torx 20 screws from it.

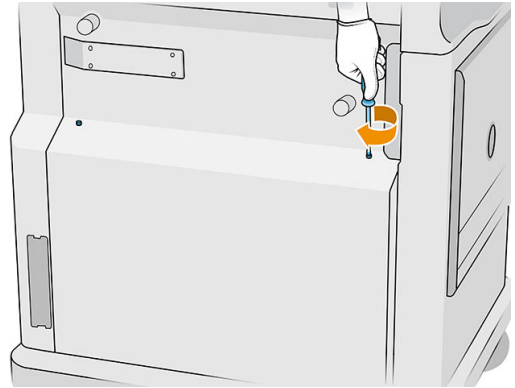
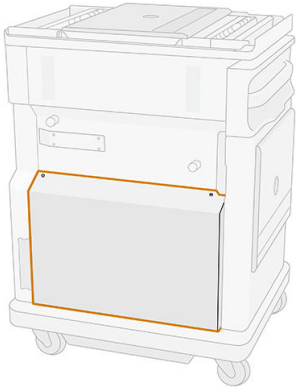

22. Loosen the six flat screws.

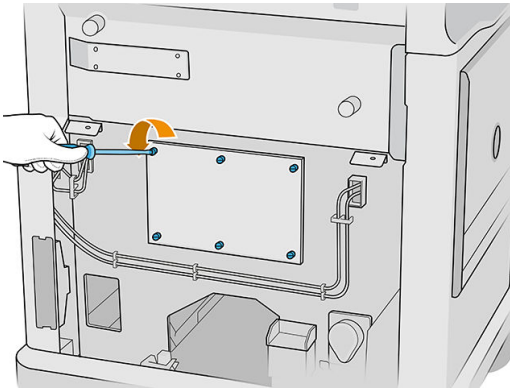

23. Remove the lid.

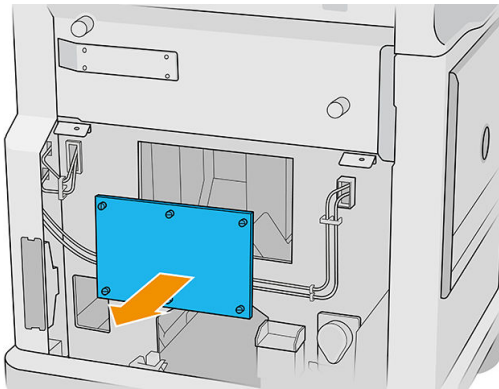

24. Using a soft-brush nozzle, vacuum the material inside the build unit from top to bottom.
 - a. Vacuum the perimeter below the platform.

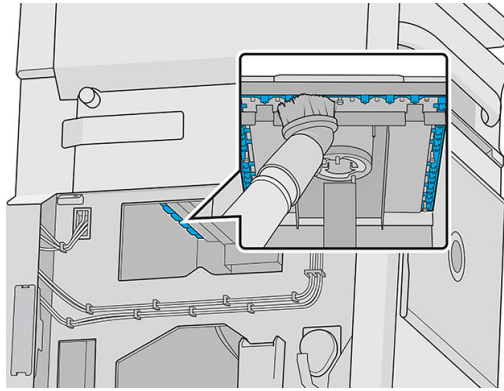

- b. Vacuum the column gasket.

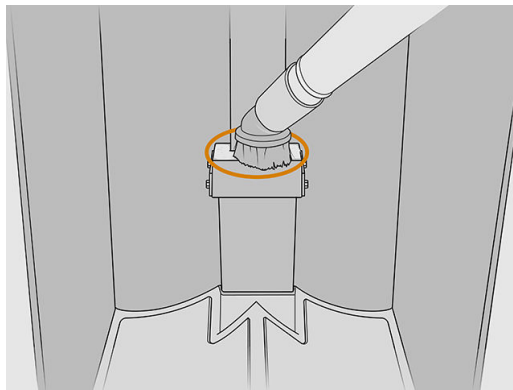

- c. Vacuum the mesh point by point. You cannot slide the nozzle over the mesh, but must vacuum one point and then lift the nozzle and put it down in another point.

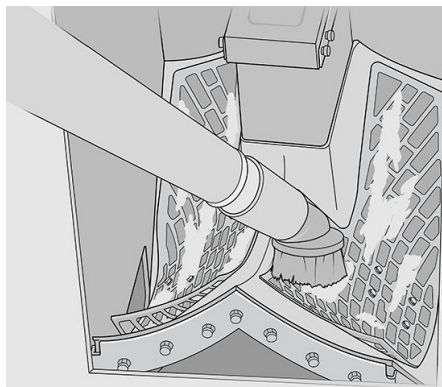

25. Using a narrow nozzle, vacuum first around the mesh and then the material-lifter inlets.

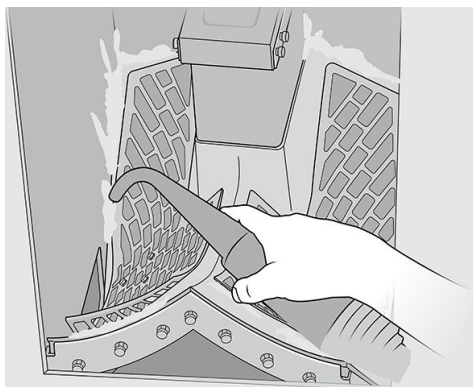

Check and clean the interior of the build unit

 **IMPORTANT:** All build units to be used with the new material must be clean before starting: see [Empty the material from the build unit on page 97](#).

To make sure that no material is left in the build unit, follow the steps below.

Prepare for cleaning

1. Ensure that you have an explosion-protected vacuum cleaner with soft-brush nozzle, an absorbent all-purpose cloth, a flat screwdriver, a Torx 20 screwdriver, and deionized water (these things are not provided by HP).
2. You are recommended to wear gloves, goggles, and mask.

Check and clean the interior of the build unit

1. Locate the material lid and remove the two Torx 20 screws from it.

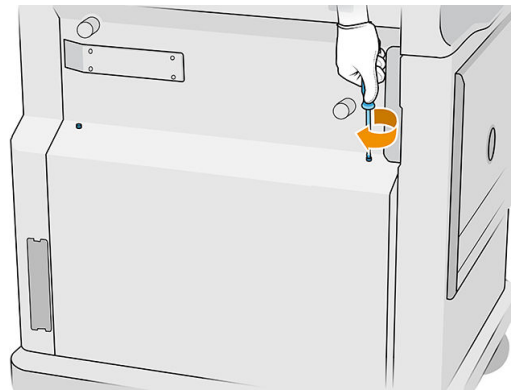
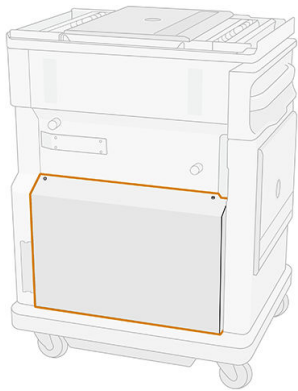

2. Loosen the six flat screws.

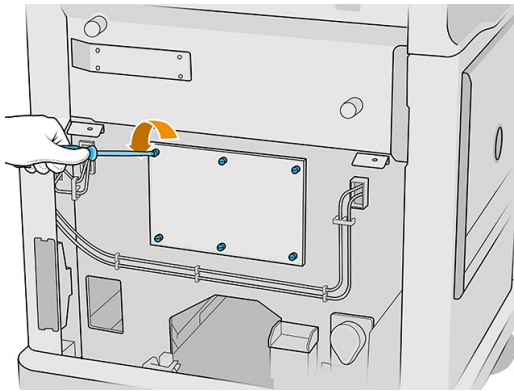

3. Remove the lid.

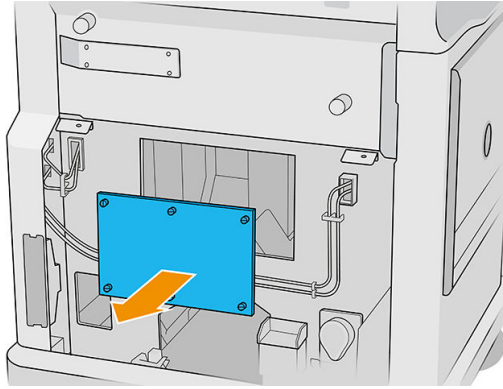

4. Check the interior of the build unit and use the explosion-protected vacuum cleaner with soft-brush nozzle, if needed, to remove the remaining material.

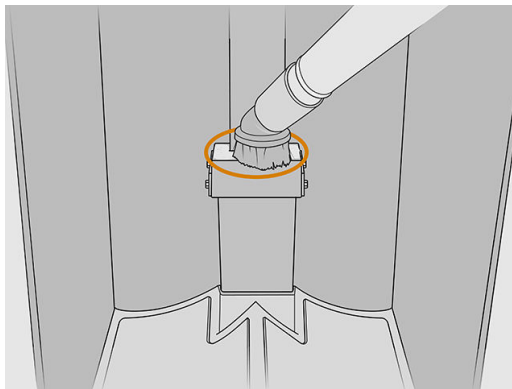

Finish cleaning

1. Tighten the four captive flat screws.
2. Put back and tighten the two Torx 20 screws.
3. Vacuum the area below the cap of the build unit's loading inlet.

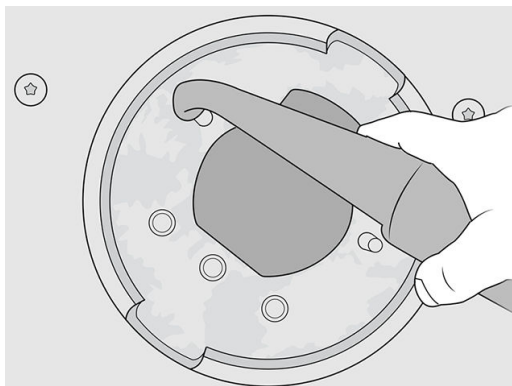

9 Print

- [Job list app](#)
- [Send a job to be printed](#)
- [Select a job to be printed](#)
- [Add job while printing \(5210 only\)](#)
- [Cancel a job](#)
- [Check status on the front panel](#)
- [Check status remotely](#)
- [Possible errors while printing](#)
- [Print modes](#)

Job list app

The job list app in the printer's front panel displays the status of all jobs. Possible statuses are:

- **Waiting to process**
- **Processing**
- **Processed:** The job is ready to be sent for printing. Either it has never been printed, or it is ready for reprinting.
- **Sent to print:** The job has started printing.

Send a job to be printed

Before sending a print job, make sure that you have done at least the required daily maintenance tasks. See [Hardware maintenance on page 119](#).

Make sure you have the build unit filled with the correct material and in the printer. See [Load material into the build unit on page 89](#).

Use the HP SmartStream 3D Build Manager to send the job to the printer. See the *HP SmartStream 3D Build Manager User Guide*.

Select a job to be printed

1. At the printer's front panel, tap **Jobs** on the home screen.

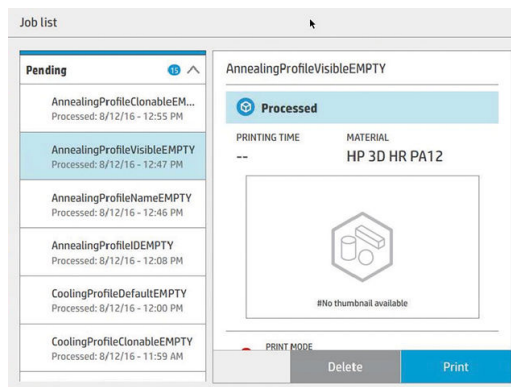

2. If the build unit has not been inserted, open the door and insert the build unit by pushing the handles.
3. Select the processed job and tap **Print**.
4. The printer checks that all subsystems and supplies are ready to complete the build. If one of them is not ready, the printer notifies and advises you: a notification appears in the job details with an accessible summary of any issues. If necessary, correct the issue(s) and resend the job for printing.
5. The printer starts the printing process. Wait until the printer tells you that the process is complete, then remove the build unit.

Add job while printing (5210 only)

If you have available space in the build unit and enough material, you can add a job to be printed while the previous job is still being printed.

To do so, select the job to be printed and tap **Add**. The printer checks whether it can be added, and adds it if feasible.

On the **Jobs** page, the **FINISH** line shows the total time to finish the currently printing job and the following jobs in the queue. It is updated whenever a job is added or removed.

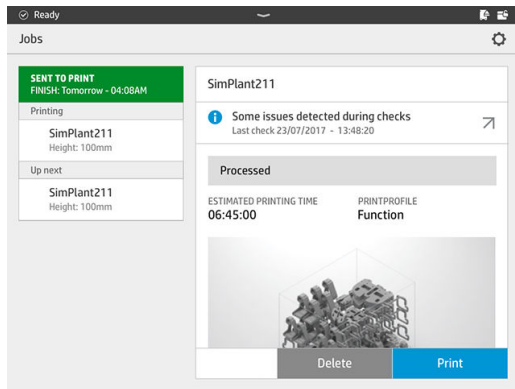

NOTE: When adding a job to the queue, the button at the bottom of the page becomes **Remove**, allowing you to remove the job from the queue and return it to its initial location.

When you add a job while printing, sacrifice layers are added between jobs; see diagram below.

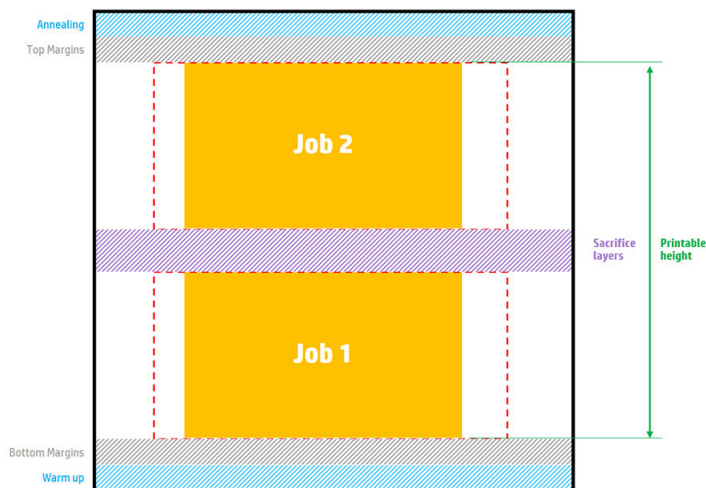

$$\text{Available printable height} = \text{Printable height} - (\text{Job CAD height} + \text{Sacrifice layers})$$

Repeated per job

A job can be added only if there is enough height available for it. Take into account that the height required is the printed height plus the sacrifice layers between jobs.

You cannot add a job while the current job is annealing.

NOTE: Adding a complex job during printing may slow down the processing of the current job, which could cause printing problems.

Cancel a job

If you need to cancel the job while printing, tap **Cancel** and confirm it in the build status app on the printer's home screen. The printer will cancel the job immediately.

IMPORTANT: When printing with TPU material, if you cancel during the annealing process, your parts may have major print-quality issues. HP does not recommend canceling.

IMPORTANT: Wait until the printer tells you it is safe to remove the build unit.

Proceed with the cooling process and unpacking if relevant. If no parts have been printed, the build unit should be cleaned and loaded before using it again.

Check status on the front panel

At the printer's front panel, the build status app on the home screen shows you the status of the build currently being printed.

- Status of the job: A progress bar shows the phase completed. The phases are warming, printing, and annealing (if selected when the job was sent to print).
- Estimated finishing time
- Job name
- Layers printed and layers in total
- Parts printed and parts in total
- Height printed and total height
- Material type

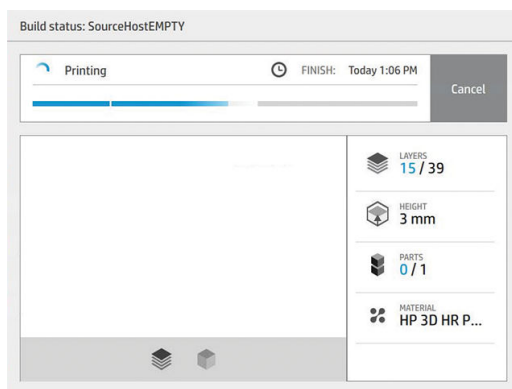

You can select an isometric or section view of the current layer, and you can navigate through layers.

Check status remotely

You can check the job status from the Command Center. See [HP SmartStream 3D Command Center on page 26](#).

Possible errors while printing

- Out of agent
- Out of cleaning roll
- Printhead error
- Broken lamp
- Crash during printing
- Power cut

In the event of an error, the printer cancels the job immediately.



IMPORTANT: Wait until the printer tells you it is safe to remove the build unit.

Proceed with the cooling process and unpacking if relevant. If no parts have been printed, the build unit should be cleaned and loaded before using it again.

Print modes

In the HP SmartStream 3D Build Manager, you can choose one of the following print modes from the print profile drop-down menu, depending on your needs:

- **Balance 2.0 mode** delivers balanced properties.
- **Fast 2.0 mode** maximizes speed for any job.

10 Unpack the build

As the build is at a high temperature while printing, you must wait about 30 minutes before extracting the build unit from the printer. Then there is some further cooling time required in order to preserve part quality.

Tips

- Wear high-temperature-resistant gloves.
- Unpack calmly.
- There are physical buttons with which you can raise or lower the printing platform to make the unpacking process more convenient.
- The sides and corners of the build chamber are colder than the center.
- If the parts are large, or the material around the parts seems very hot, leave them aside to cool down.
- If you notice that the vacuum speed slows down, try to unpack material from cooler locations or from cooled parts.

Extracting the build to the natural cooling unit

 **NOTE:** The natural cooling unit is an accessory. See [Accessories on page 22](#).

1. Remove the build unit from the printer.
2. Use an explosion-protected vacuum cleaner to remove any material from the overflow trays.
3. Remove the purge tool from its usage position, and put it in its parking position.

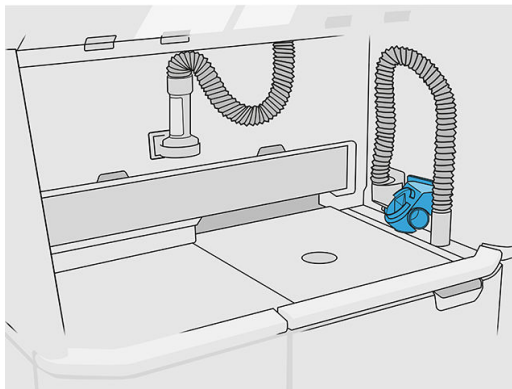

4. Insert the build unit in the processing station, go to the processing station's front panel, and tap **Build unit > Cooling unit**.
5. Select the correct natural cooling unit from the list; otherwise, it will be automatically detected by the RFID reader.

6. Open the processing-station door, put the natural cooling unit on the build unit, and ensure that it is properly attached.

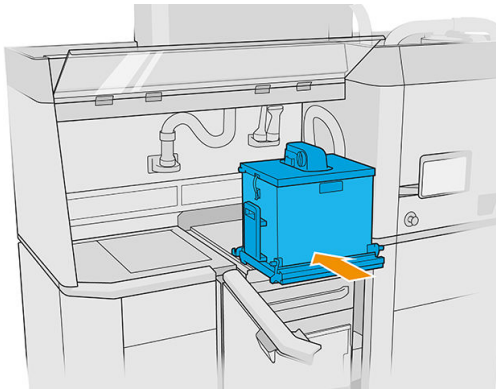

7. Remove the slicing blade from the natural cooling unit. Make sure the front flap (slicing blade flap) remains closed.

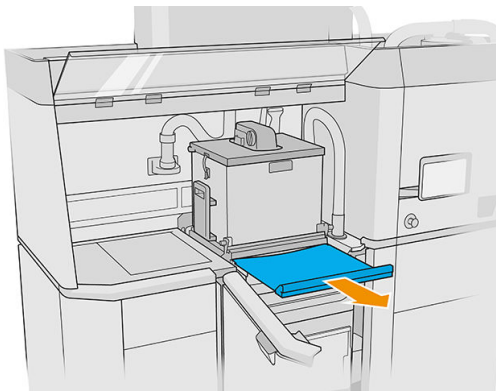

8. Connect the reusable material collector to the natural cooling unit aspiration connector.

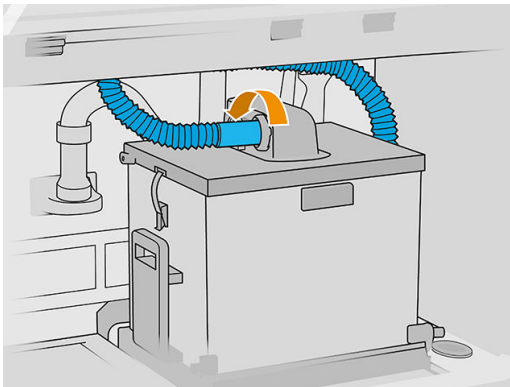

9. Once the print job has been lifted into the natural cooling unit, put the slicing blade back in place. Make sure the front flap and the slicing blade are in the correct positions.

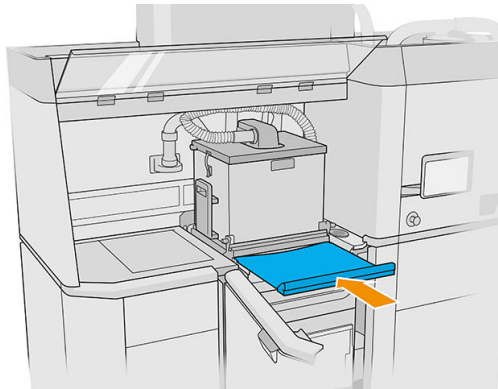

10. Remove the natural cooling unit from the processing station, using a forklift.

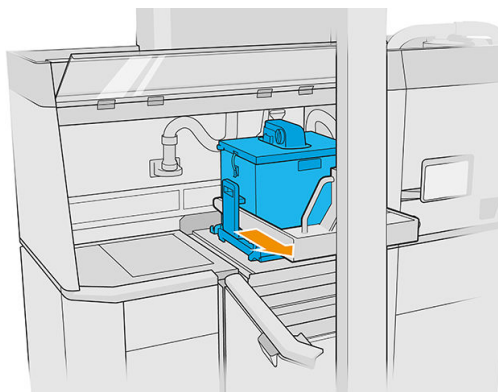

11. If any material spillage is detected, make sure the slicing blade is closed, and clean up the material with an explosion-protected vacuum cleaner.
12. After cleaning, the build unit will be ready for a new print job.

Unpacking with the natural cooling unit

 **NOTE:** The natural cooling unit is an accessory. See [Accessories on page 22](#).

1. If there is a build unit in the processing station, remove it.
2. Remove the purge tool from its usage position, and put it in its parking position.

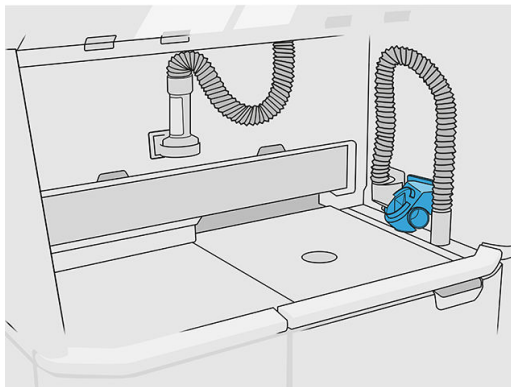

3. Go to the processing station's front panel, and tap **Build unit > Cooling unit**.

4. Put the natural cooling unit inside the processing station, using a forklift.

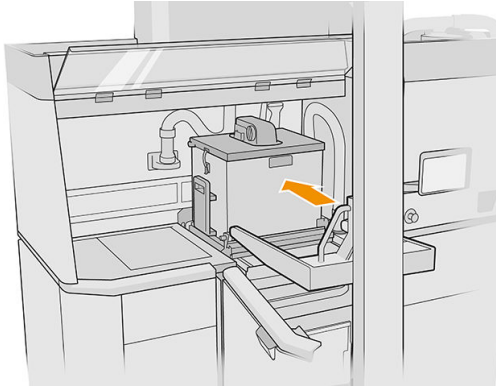

5. Make sure the natural cooling unit is in the unpacking position.
6. Put the unpacking cover in place.
7. Proceed to unpack, following the instructions on the front panel.
8. After unpacking, clean the natural cooling unit.
9. Remove the cover and take out the natural cooling unit.

Unpacking without the natural cooling unit

1. When the printer tells you to proceed, open the door, extract the build unit, and place the safety lid over it.
2. Put on heat-resistant gloves and vacuum the top surface of the build unit with an external explosion-protected vacuum cleaner.
3. At this point you can follow the natural cooling process; or, if your processing station is equipped with fast cooling, you can choose fast cooling as an alternative.

Natural cooling

- a. Move the build unit aside to cool down further.

⚠ CAUTION: You are recommended to lock the wheels of the build unit while it is outside the printer.

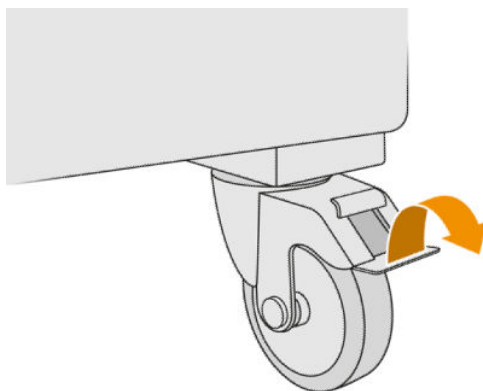

- b. Wait. The cooling time depends on the size of the build.

- c. Insert the build unit into the processing station.

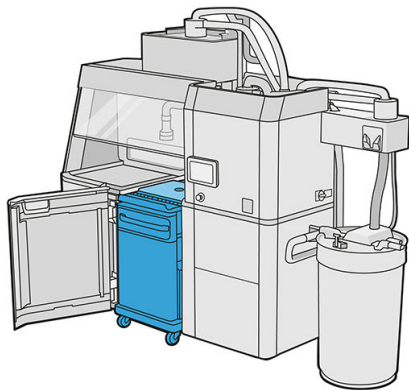

Fast cooling

- a. The build unit must be left to cool naturally for 3 or 4 hours before fast cooling can start. It does not need to be inside the processing station during this time.
- b. When you have inserted the build unit into the processing station, go to the processing station's front panel and tap **Build unit** > **Fast cooling**.
- c. Fast cooling starts. You can tap  at any time to cancel fast cooling. To resume the process, ensure that the build unit is inserted, and tap **Fast cooling**.

Default fast cooling times for PA11 and PA12 material

	PA11	PA12
Half-full build chamber (190 mm)	13.4 h	7.4 h
Full build chamber (380 mm)	18 h	10 h

Before starting the fast cooling process, you can modify the timing by tapping **Modify**.

 **TIP:** **Modify** can be locked so that only administrators can modify the timing.

The timing is changed based on a cooling factor, which is related to speed; it is used to calculate the fast cooling time for different job heights. Modifying this value may compromise part quality.

 **NOTE:** The use of fast cooling may cause less uniformity in part cooling rates, and parts may finish at higher temperatures than with natural cooling.

- d. Connect the reusable material collector to the safety lid, and tap **Start** on the front panel, which will tell you the remaining time.

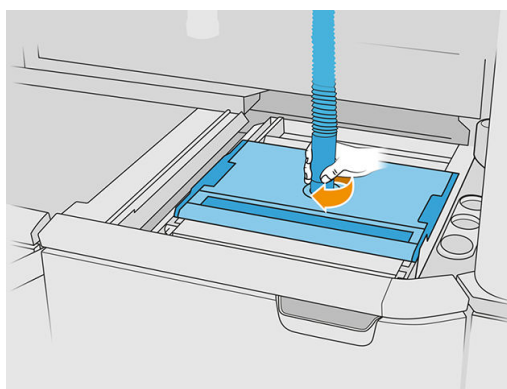
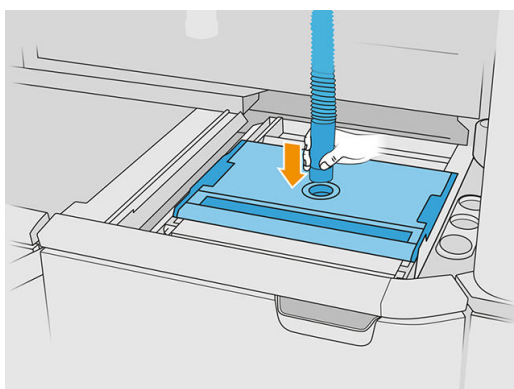

 **IMPORTANT:** Ensure that the reusable material collector is in the high-suction position.

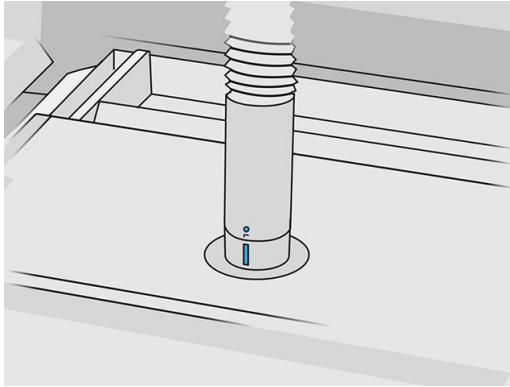

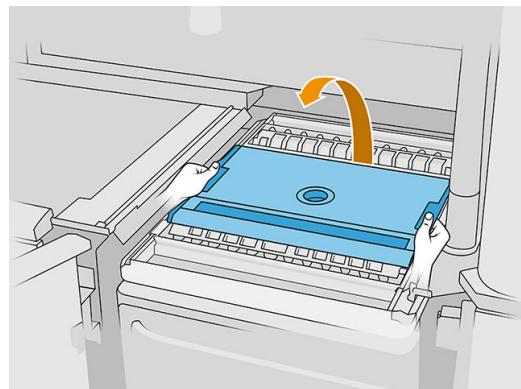
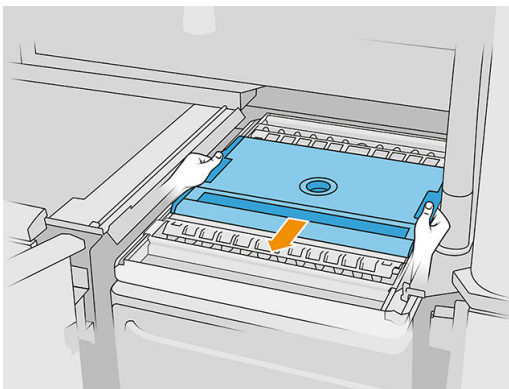

4. When cooling is complete, remove the safety lid and park it on the front of the build unit.



5. Use the build unit app on the processing station's front panel to check that the build is ready for unpacking.
6. At the processing station's front panel, tap **Build unit** > **Unpack** > **Start** to start the unpacking process.

 **IMPORTANT:** The vacuum is activated when you tap **Start**, and the dust extractor is activated to keep the process clean.

 **CAUTION:** Wear heat-resistant gloves.

 **TIP:** Close the hood to improve the performance of the dust extractor.

7. Redeploy the reusable material collector. You can use one of the following nozzles:

- Crevice nozzle, for cleaning the feed tray and narrow areas
- Fine mesh nozzle, with a 2 mm mesh, for unpacking very small parts
- Wide nozzle, for cleaning the working area rapidly

 **CAUTION:** Do not use the wide nozzle to clean the mesh shaker (on the feed trays of the build unit), as you could damage the accessory and leave residues inside.

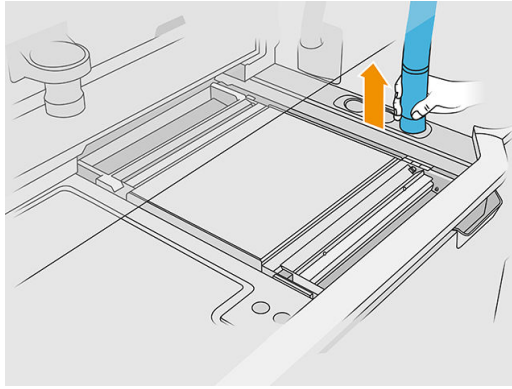

 **NOTE:** You can regulate the suction power by rotating the tip of the material collector hose.

8. Vacuum the external perimeter of the platform (this step is unnecessary if you have used fast cooling).

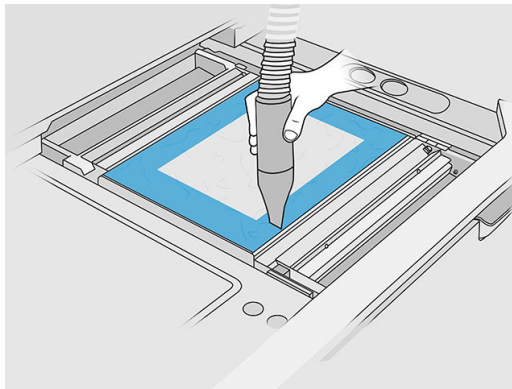

9. Raise the platform by pressing the button.

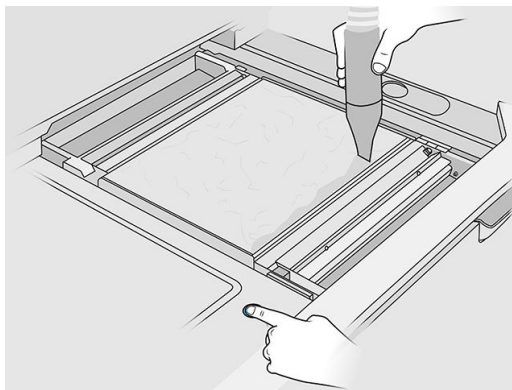

10. Vacuum the build to reveal the parts.

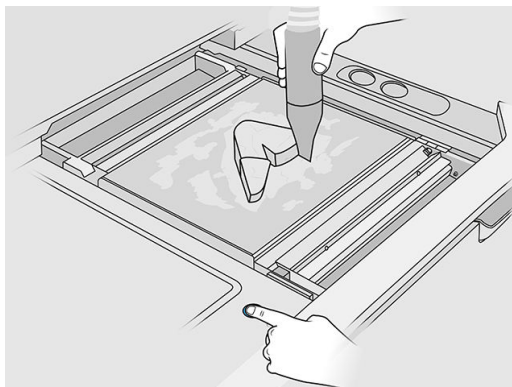

11. Clean each part separately to avoid having big clumps of material covering the part. You don't need to clean every surface thoroughly because:
 - The material that is closest to the part or attached to it may reduce the overall quality of reused material.
 - That material will be removed anyway during sandblasting and postprocessing.

The example below shows a part that is ready for the bead blast.



Continue until all parts are extracted from the build chamber. Use the physical buttons to lift the platform to reach all parts.

12. After checking that all parts are unpacked, put them in a box and take them to the postprocessing section.

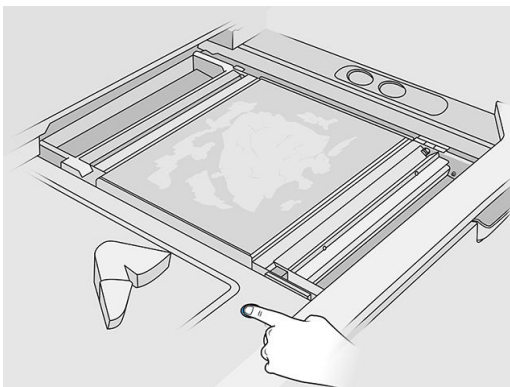

13. Ensure that the printing platform is at its highest position.
14. Vacuum the empty printing platform and feed tray.

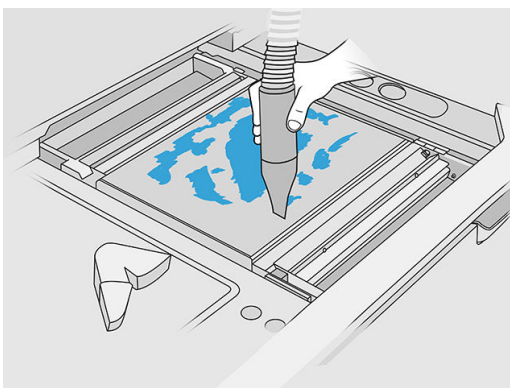

15. Tap **Finish** on the front panel.

16. Clean the surface of the build unit. See [Clean the surface of the build unit on page 221](#).
17. Vacuum the platform control buttons to prevent loose material from blocking them.

11 Part cleaning and postprocessing

Once parts have been unpacked from the build in the processing station, they should be cleaned. There are different processes that can be followed, depending on your needs. In general, you will need equipment not provided by HP. The main process recommended by HP is a combination of bead blasting (first) and air blasting (second).

- Bead blasting consists of applying compressed air mixed with an abrasive to the part in order to remove the attached material. This is a generally appropriate solution; however, you may want to select different abrasives or pressures for specific purposes.
- Air blasting consists of applying compressed air to the part in order to remove any material remaining after bead blasting.

Depending on your specific needs, other postprocessing methods may be suitable for you.

The following options are available to improve surface finishing:

- Tumbling: The part is immersed in a vibro-tumbler full of abrasives, to smooth any surface roughness.
- Hand sanding: The surfaces of the part are smoothed by abrasion with sandpaper.

The following options are available for color-related finishing:

- Bead blasting with other additives consists of applying compressed air mixed with an abrasive and a colored additive to the part in order to achieve homogeneous surface color.
- Dyeing consists of immersing the part in a controlled dyeing bath. All details and cavities of the part can be reached.
- Painting the part with spray can, spray gun, or brush. For specific color finishing, HP recommends applying a primer before painting the part. Repeat the process several times for optimal results.

Other industry-standard postprocessing methods may be used:

- Gluing, bonding, sealing
- Drilling, tapping
- Plating
- Coatings for wear resistance, conductivity, temperature resistance, strength, watertightness, resistance to chemicals, gloss properties, UV protection, and so on

Contact your HP support representative to discuss solutions for your specific needs.

Consult your usual EHS specialist for advice on the appropriate measures for your location depending on the post-processing method you use. Consult your local authorities to determine the correct manner in which to dispose of wastes.

12 Hardware maintenance

⚠ WARNING! Hardware maintenance may be performed by trained personnel only. During printer installation, the designated personnel receive training for safe operation and maintenance of the printer. No-one should use the printer without this training.

- [Safety precautions](#)
- [Maintenance resources](#)
 - [Maintenance kits](#)
 - [Kit contents and recommended tools](#)
- [Printer maintenance](#)
 - [Summary of maintenance operations](#)
 - [Maintenance operations](#)
- [Processing-station maintenance](#)
 - [Summary of maintenance operations](#)
 - [Maintenance operations](#)
- [Build-unit maintenance](#)
 - [Summary of maintenance operations](#)
 - [Maintenance operations](#)
- [Move or store the product](#)

Safety precautions

Read and follow the safety precautions in this guide to make sure you use the equipment safely: see [Safety precautions on page 5](#).

You are expected to have the appropriate technical training and experience necessary to be aware of hazards to which you may be exposed in performing a task, and to take appropriate measures to minimize the risks to yourself and to others.

Maintenance resources

Maintenance kits

Name	Purpose	How to order	Part number
Printer initial maintenance kit	For periodic maintenance operations that require the replacement of printer parts; lasts for about 100 full jobs	Through the usual channel	UB8N0E
Processing-station maintenance kit	For periodic maintenance operations that require the replacement of processing-station parts	Through the usual channel	UB8N1E

Kit contents and recommended tools



NOTE: The contents of each kit may vary.

Printer initial maintenance kit contents

Part	Quantity	Purpose
Printer top-enclosure left fan filter	2	Replace the top-enclosure left and right fan filters on page 171
Printer top-enclosure right fan filter	4	Replace the top-enclosure left and right fan filters on page 171
Heating lamp	2	Replace a heating lamp on page 194
Fusing lamp	6	Replace the fusing lamps on page 53
Printhead cleaning roll rubber blade	2	Replace the printhead cleaning roll's rubber blade on page 181

Printer yearly maintenance kit contents

Part	Quantity	Purpose
Print-zone filter	2	Replace the print-zone filter on page 169
Build-unit material chamber filter	6	Replace the build-unit material-chamber filters on page 226
Printer e-cabinet filter	1	Replace the e-cabinet filter on page 165
Printer power-box right filter	1	Replace the power-box fan filters on page 167
Printer power-box left filter	1	Replace the power-box fan filters on page 167
Top heating lamps fan filter	2	Replace the heating-lamp filter on page 163
Mask	2	General maintenance processes
Safety goggles	1	General maintenance processes

Processing-station maintenance kit contents

Part	Quantity	Purpose
Vacuum pump filter	2	Replace the vacuum-pump filter on page 215
Dust extractor filter	2	Replace the dust extractor filters on page 214
E-cabinet fan filter	4	Replace an e-cabinet fan filter on page 212
Hand air blower	1	Clean the loading nozzle sensor on page 204

Other kits

The following kits can be used when a specific component is needed.

Kit	Part number	Quantity	Part
Printer top enclosure right filters kit	1MZ21	2	Top-enclosure right fan filter
Printer top enclosure left filters kit	1MZ22	1	Top-enclosure left fan filter
Printer heating lamps kit	1MZ26	2	Heating lamp
Printer fusing lamps kit	1MZ27	2	Fusing lamp
Build unit maintenance kit #1			Platform nut / Column gasket

Preventive maintenance

The purpose of scheduled preventive maintenance is to perform regular maintenance operations as required, in order to prevent possible failures from occurring and ensure good performance throughout the life of the product.

For each scheduled preventive maintenance action, there is an internal life counter in the firmware that counts a variable related to the life of the component.

When the internal life counter reaches the limit for a preventive maintenance action (set according to testing and development), an alert is displayed in the Notification center on the Front panel.

Preventive maintenance alerts and actions

There are two types of preventive maintenance alerts:

- Alerts that require a service engineer to complete the action (contact your support representative)
There are three such alerts, corresponding to the three maintenance kits described below.
- Alerts that require the customer to complete the action

Service preventive maintenance alerts

When a preventive maintenance number is displayed, before dispatching the part, a check is required in case there are other preventive maintenance alerts almost due; in which case, they can be done together.

Alert	Description
Printer maintenance kit #1 required	Replace the printhead carriage and scan-axis assembly
Printer maintenance kit #2 required	Replace the recoating unit carriage and impelling system
Build unit maintenance kit #1 required	Replace platform nut and column gasket

 **NOTE:** The Notification Center displays alerts only for the build unit that is inserted at that time.

Operator preventive maintenance alerts

The Notification Center displays alerts whenever a maintenance action is required.

Alert	Action required
Replace fusing agents intermediate tanks	Replace an intermediate tank on page 198
Replace detailing agents intermediate tanks	Replace an intermediate tank on page 198
Replace rubber blade	Replace the printhead cleaning roll's rubber blade on page 181

Check for alerts through the front panel status center

Any alert concerning the printer and the build unit preventive maintenances is displayed at the top of the front panel in the status center, which can be expanded by swiping down from the top.

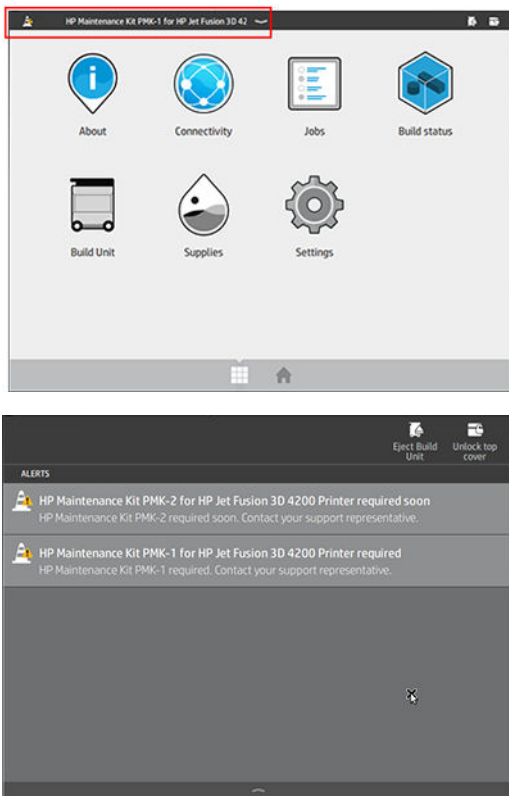

 **NOTE:** The status center displays alerts only for the build unit that is inserted at that time.

Check preventive maintenance usage level on the front panel

You can check the preventive maintenance usage levels, which are automatically converted to a percentage according to the life counter values, in the **Maintenance** application.

To do so, select **Settings > Maintenance > Show PMK status** and follow the instructions.

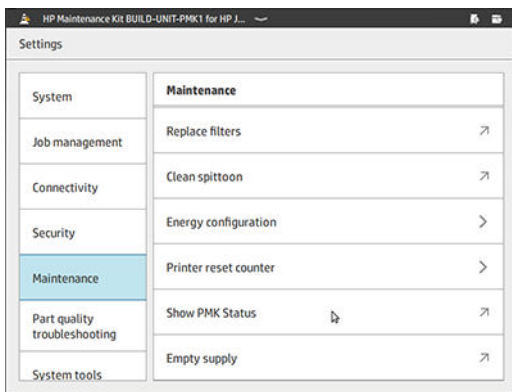

The front panel displays the current status of all user and service preventive maintenances. It also displays the maintenances required for the build unit currently inserted, if any.

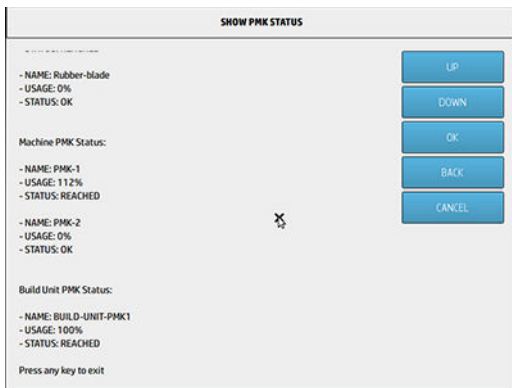
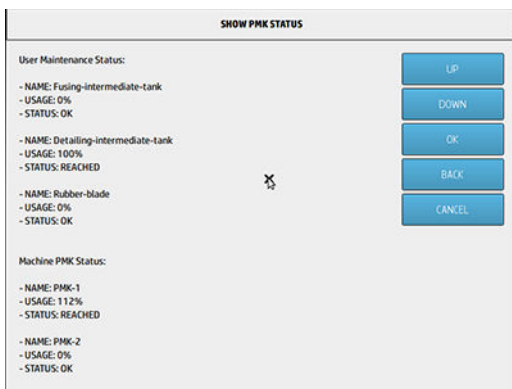

 **NOTE:** Only the usage levels for the build unit that is inserted at that time are displayed.

 **NOTE:** The percentages given are estimates only.

Maintenance tools recommended but not provided

- Spiral scourer, for some cleaning operations
Use a scourer that does not scratch glass; test it on a corner if in doubt.



- Absorbent all-purpose cloth, for cleaning covers and general cleaning

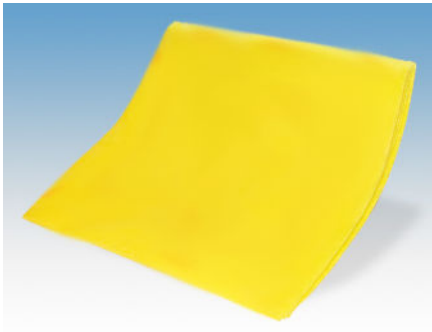

- Lint-free cloth or all-cotton cloth, for cleaning covers and general cleaning

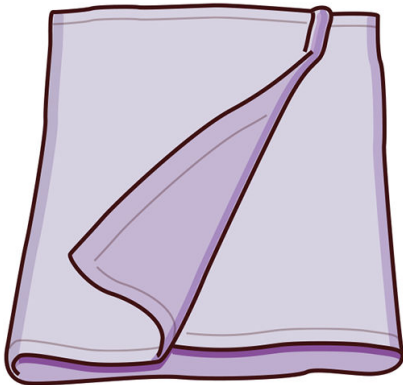

- General-purpose industrial cleaner (such as Simple Green industrial cleaner), for general cleaning
- Deionized water, for general cleaning

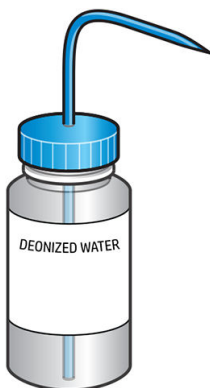

- Explosion-protected vacuum cleaner, with nozzle accessories for general cleaning (crevice and soft brush nozzles highly recommended)



 **NOTE:** Inside and outside the equipment should be cleaned regularly with an explosion-protected vacuum cleaner to prevent dust from accumulating. Do not sweep the dust or try to remove it with a compressed-air gun.

An explosion-protected vacuum cleaner certified for collection of combustible dust is required for cleaning. Take measures to mitigate material spillage and avoid potential ignition sources such as ESD (ElectroStatic Discharges), flames, and sparks. Do not smoke nearby.

- Flashlight, for general use



- Folding steps, for general use



- Flat screwdriver



- Torx screwdriver



Printer maintenance

Summary of maintenance operations

Frequency	Maintenance operation	Part description and number
After every job	Clean the print zone, carriage, and housing structure on page 128	
	Clean the spittoon on page 131	
	Clean the bottom of the carriage and of the fusing lamps on page 133	
	Clean the thermal camera glass on page 134	
Once a day	Clean the front bearing on page 136	
Once a week	Clean the exterior of the printer on page 137	
	Clean the recoating roller and recoating plates on page 138	
	Clean the scan-axis wipers on page 142	
	Clean the inside of the carriage on page 143	
	Clean the service-station caps on page 145	
	Clean the top-enclosure fan filters on page 146	
	Clean the front bar on page 148	
Clean the material extraction system on page 149		
Once every 2 weeks	Clean the fusing-lamp glasses on page 150	

Frequency	Maintenance operation	Part description and number
Once every 6 months	Clean the bottom glass of the heating lamps on page 155	
	Clean the recoater's left box and left rod on page 157	
Once a year	Check the functionality of the Residual Current Circuit Breakers (RCCBs) on page 202	
	Check that the printer is correctly earthed on page 202	
At printhead reject or reset	Clean the printhead contacts in the carriage on page 160	
	Clean the printhead contacts on the printhead on page 161	
When required	Clean the print-zone window on page 162	
	Replace the print-zone filter on page 169	Printer yearly maintenance kit (1MZ24)
	Replace the heating-lamp filter on page 163	Printer yearly maintenance kit (1MZ24)
	Replace the e-cabinet filter on page 165 and Replace the power-box fan filters on page 167	Printer yearly maintenance kit (1MZ24)
	Replace the top-enclosure left and right fan filters on page 171	Printer initial maintenance kit (1MZ23), provided with your printer When required, use the printer top enclosure right filter kit (1MZ21) and printer top enclosure left filter kit (1MZ22)
	Replace a primer on page 172	Go through the usual channel to purchase spares
	Replace a service-station cap module on page 175	Go through the usual channel to purchase spares
	Replace the printhead cleaning roll's rubber blade on page 181	Printer initial maintenance kit (1MZ23), provided with your printer
	Replace a service-station drop-detector module on page 183	Go through the usual channel to purchase spares
	Replace the recoating roller and recoating plates on page 187	Go through the usual channel to purchase spares
	Replace the bottom glass of the heating lamps on page 190	Go through the usual channel to purchase spares
	Replace the fusing lamps on page 53	Printer initial maintenance kit (1MZ23), provided with your printer When required, use the printer fusing lamps kit (1MZ27)
	Replace a fusing-lamp external glass on page 190	Go through the usual channel to purchase spares
	Replace a fusing-lamp internal glass on page 192	Go through the usual channel to purchase spares
	Replace a heating lamp on page 194	Printer initial maintenance kit (1MZ23), provided with your printer When required, use the printer heating lamps kit (1MZ26)
	Replace an intermediate tank on page 198	Go through the usual channel to purchase spares
Replace the cleaning-roll collector on page 199	Go through the usual channel to purchase spares	
Replace the material extraction system on page 200	Go through the usual channel to purchase spares	

Quick graphical reminders of frequent operations

After-each-job maintenance operations (25–30 min)

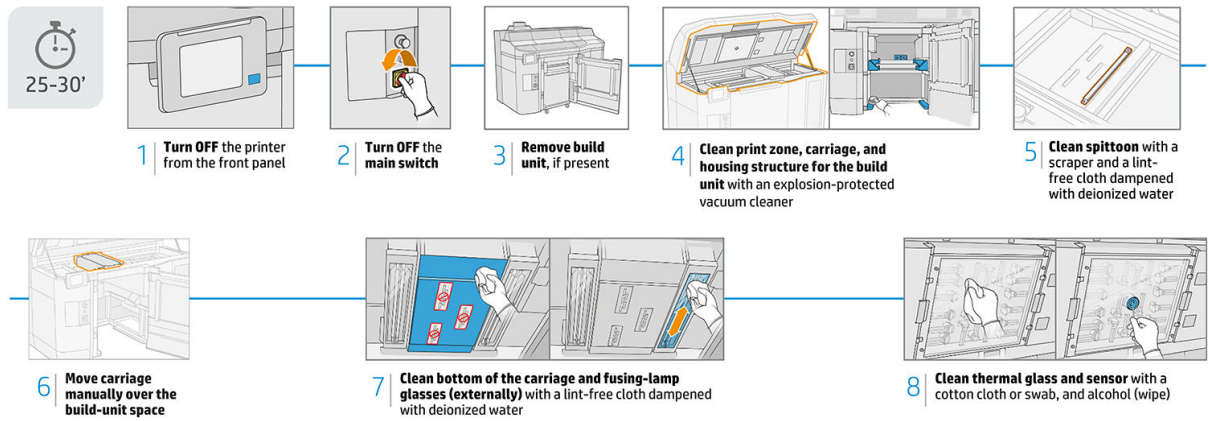

Weekly maintenance operations (60 min)

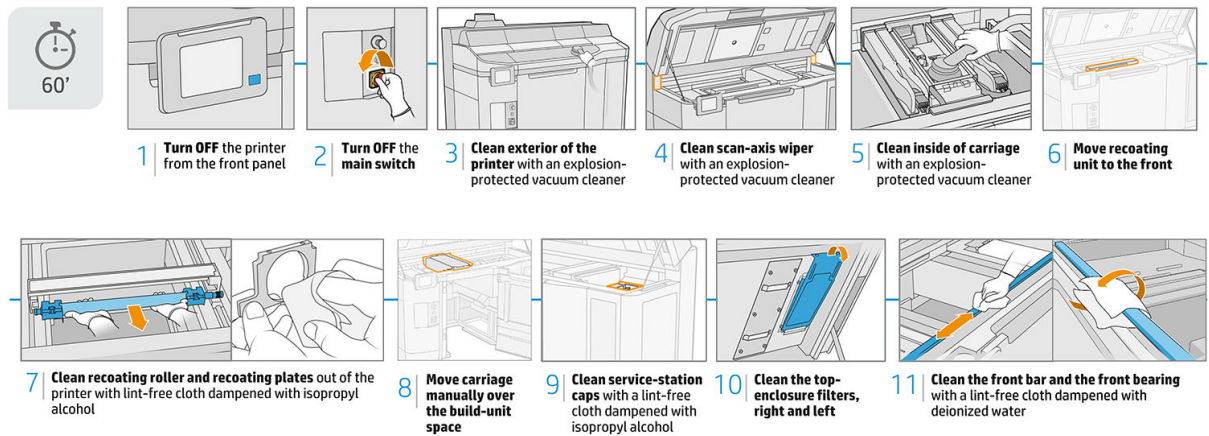

Maintenance operations

Clean the print zone, carriage, and housing structure

Prepare for cleaning

1. Ensure that you have an explosion-protected vacuum cleaner, an absorbent all-purpose cloth, and deionized water (these things are not provided by HP).
2. If the build unit is in the printer, remove it.
3. Ensure that the printer is not printing.
4. If a job has just been printed, wait about 20 minutes for the printer to cool down.
5. You are recommended to wear gloves and goggles.

6. Open the top cover.

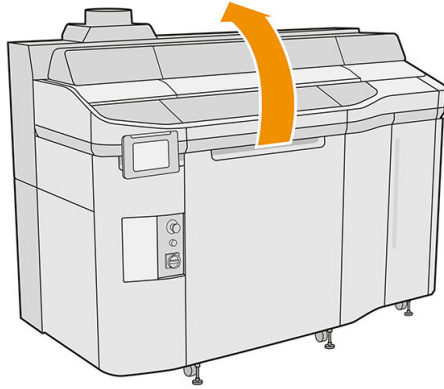

Clean the printer

1. Vacuum all the top cover surfaces including the heating-lamp quartz-glass zone and the left and right filters.

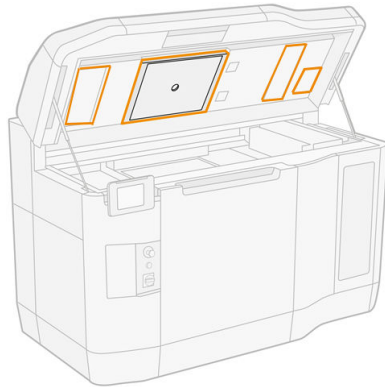

 **NOTE:** If the internal metallic part is dirty, clean it with a lint-free cloth dampened with water.

2. Clean the dust from the print zone using an explosion-protected vacuum cleaner with a soft brush nozzle.

 **CAUTION:** When vacuuming the scan axis or recoater curtains, do not push too hard against the curtains: they could bend inside and slip out of their guides.

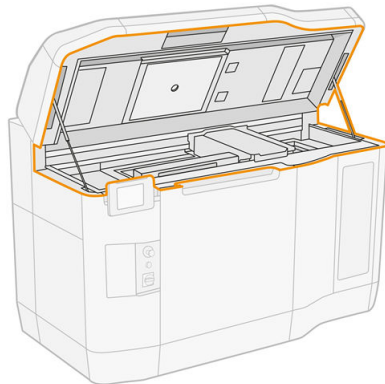

3. Vacuum the whole print carriage and capping zone. Move the print carriage manually if necessary, slowly and carefully. Additionally, you can use a lint-free cloth dampened with deionized water to clean the surfaces. Make sure that the carriage is dry before printing.

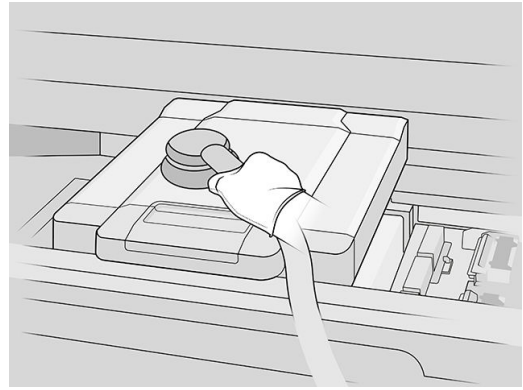
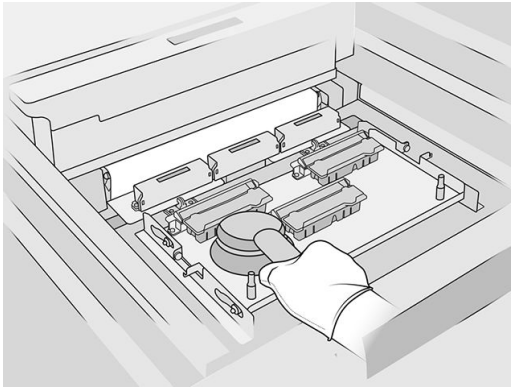

4. Vacuum the whole recoating unit. Additionally, you can use a lint-free cloth dampened with deionized water to clean the surfaces. Make sure that the carriage is dry before printing.

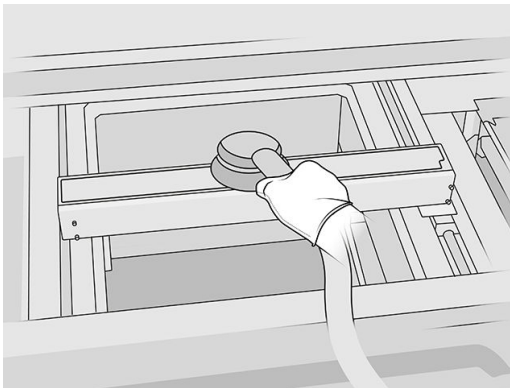

5. Vacuum the left area of the printing zone: the spittoon, cooling plates, and blowers.
6. Vacuum the metallic sheets on both sides of the printing platform, then clean them with a lint-free cloth dampened with deionized water.

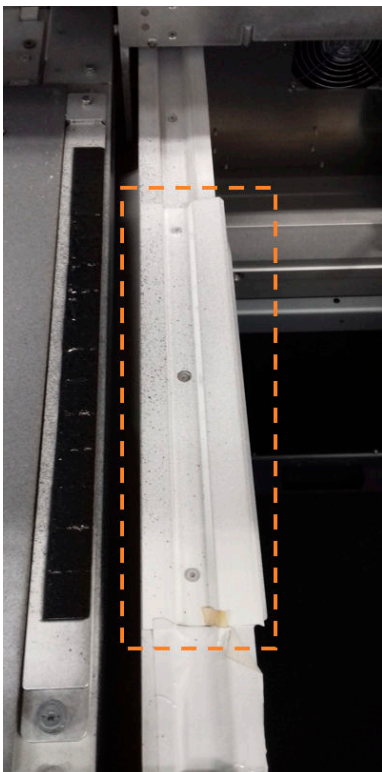

7. Vacuum the housing structure for the build unit and its internal parts.

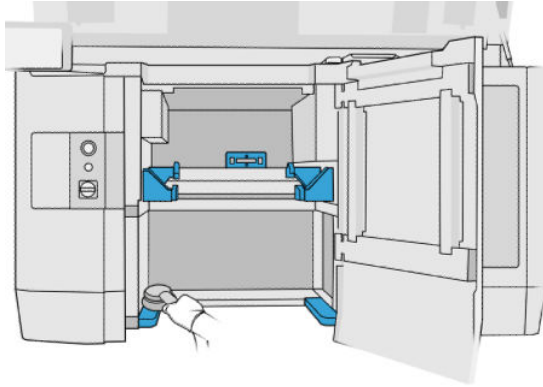

Make sure there is no material left on the build unit seal. Clean it with an explosion-protected vacuum cleaner, then wipe it with a cloth dampened with deionized water. If any material is still left, remove it with a scraper.

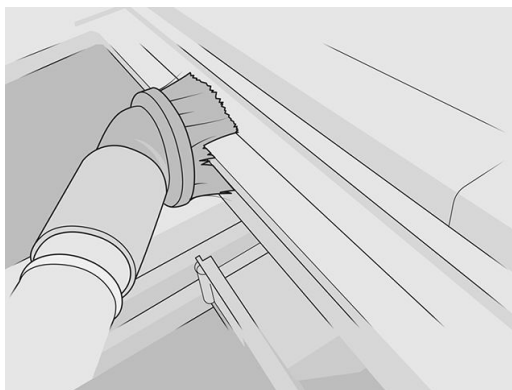

Clean the spittoon

Prepare for cleaning

1. Ensure that you have a plastic scraper, lint-free cloth, deionized water, and a general-purpose industrial cleaner, such as Simple Green industrial cleaner (these things are not provided by HP).
2. Ensure that the printer is not printing.
3. If a job has just been printed, wait about 20 minutes for the printer to cool down.
4. You are recommended to wear gloves.

Locate the spittoon

1. Open the top cover.

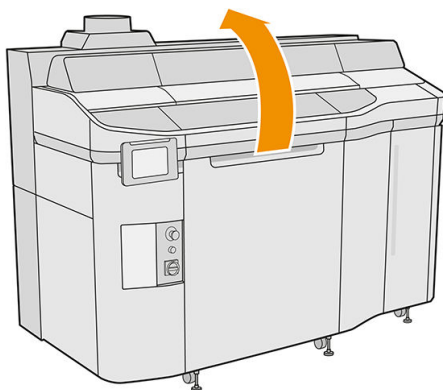

2. Locate the spittoon and check whether it is dirty.

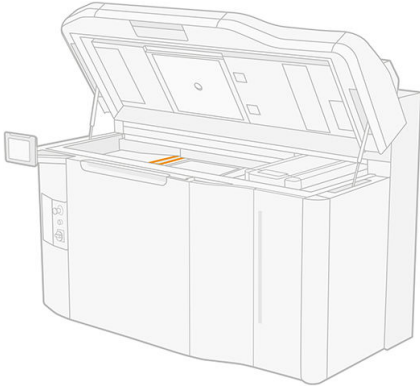

Clean the spittoon

1. Remove the screw, then remove the spittoon from the printer.

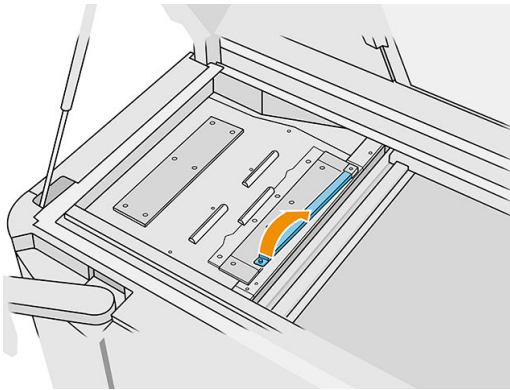

2. Scrape the spittoon with a plastic scraper.

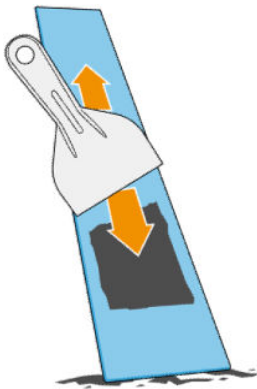

3. Clean the spittoon with a lint-free cloth dampened with deionized water.



NOTE: About once a month, turn off the printer, and clean the spittoon area with a lint-free cloth dampened with a general-purpose industrial cleaner, such as Simple Green industrial cleaner. Remove any remaining soap foam with a dry cloth.

4. Put back the cleaned spittoon, inserting the rear end first.
5. Reinsert and tighten the screw.

Finish checking/cleaning

1. Close the top cover.
2. At the front panel, tap , then **Maintenance > Clean spittoon**.

Clean the bottom of the carriage and of the fusing lamps

Prepare for cleaning

1. Ensure that you have a lint-free cloth and deionized water (these things are not provided by HP).
2. Ensure that the printer is not printing.
3. If a job has just been printed, wait about 20 minutes for the printer to cool down.
4. You are recommended to wear gloves and goggles.
5. Open the build-unit door and remove the build unit from the printer, if it is present.

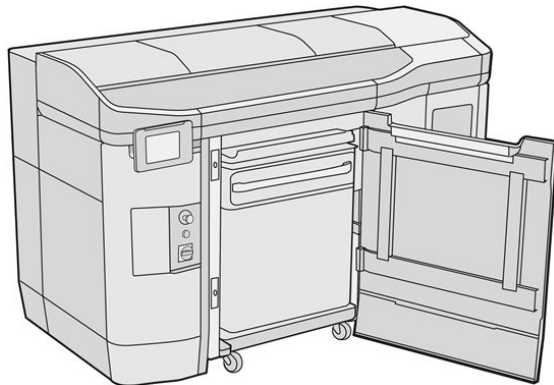

6. Open the top cover.
7. Move the print carriage manually over the build unit space, slowly and carefully.



Risk of burns



Crush hazard



Risk of trapped fingers



Hazardous moving
part



Light radiation hazard



Electric shock hazard

For more safety information, see [Safety precautions on page 5](#)

Clean the bottom of the carriage

1. Clean the carriage bottom with a lint-free cloth dampened with deionized water.

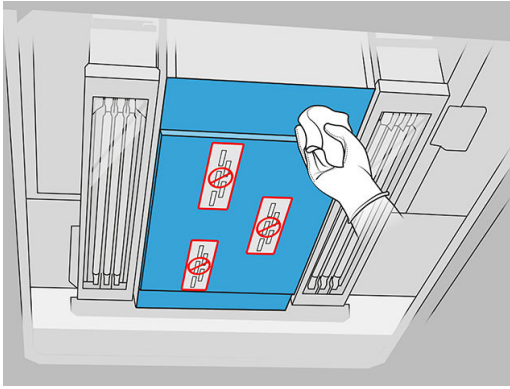

⚠ CAUTION: Be very careful not to touch the printheads.

2. Clean the bottoms of both fusing-lamp glasses with the same cloth.

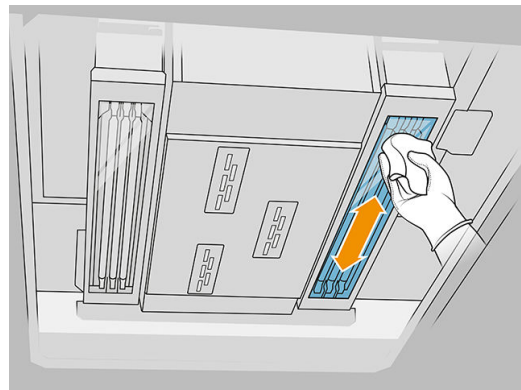
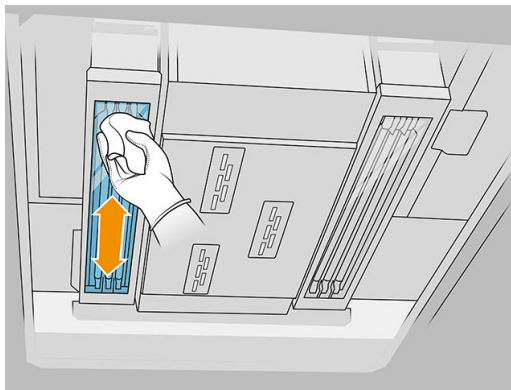

Continue cleaning until each glass is completely clean.

If there is some plastic or material stuck to the glass, try to remove it: see [Clean the fusing-lamp glasses on page 150](#). Failing that, dispose of the glass and install a new glass: see [Replace a fusing-lamp external glass on page 190](#).

Finish cleaning

1. Put the print carriage cover back into place.
2. Close the top cover.
3. Close the build-unit door.
4. Ensure that all windows, covers, and doors are closed and remain in their original positions.

Clean the thermal camera glass

Prepare for cleaning

1. Ensure that you have an explosion-protected vacuum cleaner, a supply of soft cloths, a mild, non-abrasive detergent, a general-purpose industrial cleaning liquid, and deionized water (these things are not provided by HP).
2. If the build unit is in the printer, remove it.
3. Ensure that the printer is not printing.
4. Turn off the printer.

5. If a job has just been printed, wait about 20 minutes for the printer to cool down.
6. You are recommended to wear gloves and goggles.
7. Open the top cover.

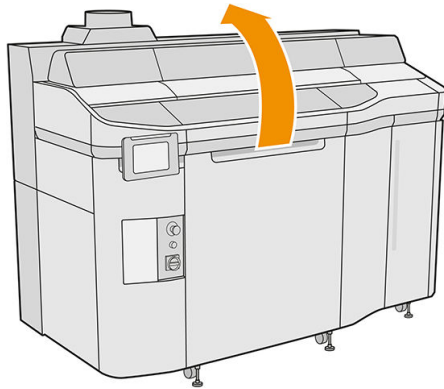

Clean the thermal camera glass

1. Vacuum the sensor glass with a soft brush nozzle.

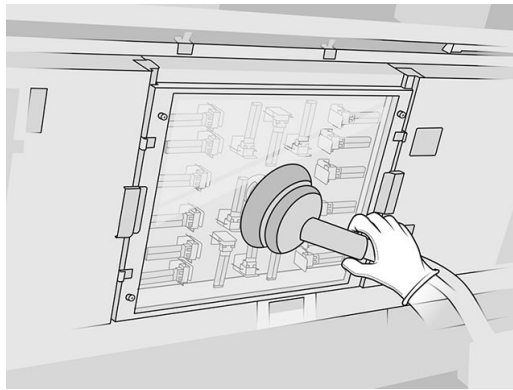

2. Clean the external surface of the sensor glass:
 - a. Wipe the glass surface with a soft, clean cloth dampened with a general-purpose industrial cleaner, such as Simple Green industrial cleaner. Remove any remaining soap foam with mixture of mild, non-abrasive detergent and deionized water (in proportions recommended by the detergent manufacturer). Then rinse the glass with another cloth dampened with deionized water, and wipe it with a dry cloth.

 **NOTE:** Isopropyl alcohol or acetone may be used as an alternative to the general-purpose industrial cleaner. In this case, after cleaning it is only necessary to wipe the glass with a dry, clean, soft, all-cotton cloth.

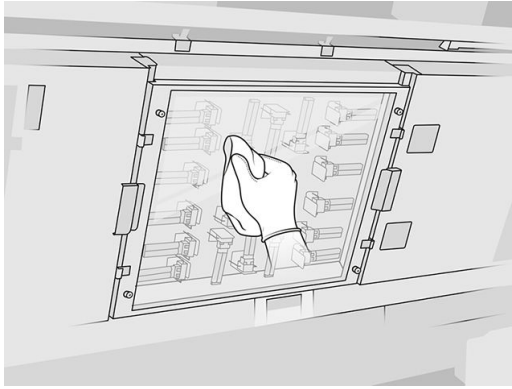

- b. If necessary, clean the glass with a scourer.
 - c. Continue cleaning the glass with the cloth and scourer until it is completely clean.
 - d. Wait until the glass is dry to start printing.
3. Wipe the sensor glass clean by rubbing the surfaces with a clean, soft, all-cotton cloth or cotton swab dampened with a mixture of mild, non-abrasive detergent and deionized water (in proportions recommended by the detergent manufacturer). Then rinse the sensor glass with another cloth dampened with deionized water, and wipe it with a dry cloth.

CAUTION: Clean only the sensor glass: try to avoid wetting any other parts of the printer.

CAUTION: If the sensor glass is left to dry by itself, it may become permanently stained.

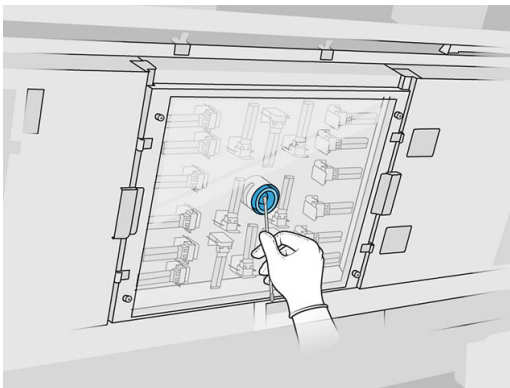

Clean the front bearing

1. Turn off the printer.
2. Insert a piece of thin, lint-free cloth into the gap between the front bar and the structure, and wrap it over the bar.

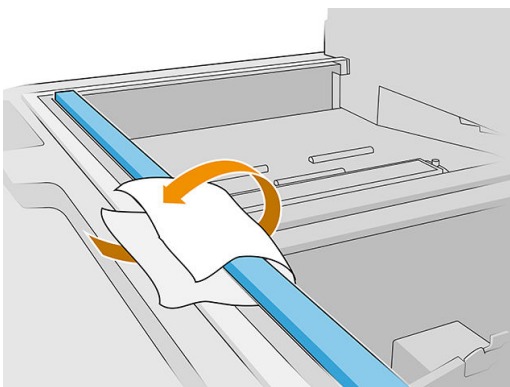

3. Dampen the cloth with deionized water.

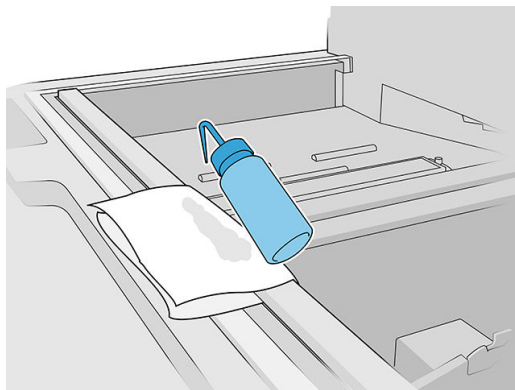

4. Move the carriage slowly and carefully over the cloth.

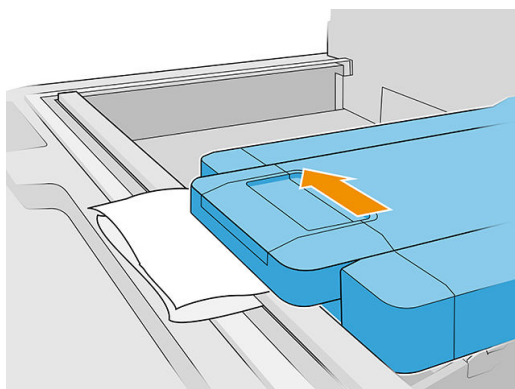

5. Move the cloth back and forth below the carriage (parallel to the front bar) to ensure that the bearing's surface is being cleaned. Repeat this movement in different positions to ensure that the whole bearing surface is cleaned.

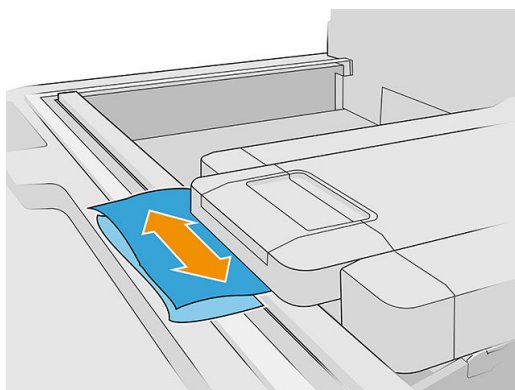

Clean the exterior of the printer

1. Check the whole printer for dust, material, or aerosol on covers, print-zone windows, doors, and so on.

2. If necessary, clean the printer further using an explosion-protected vacuum cleaner with a soft brush nozzle.

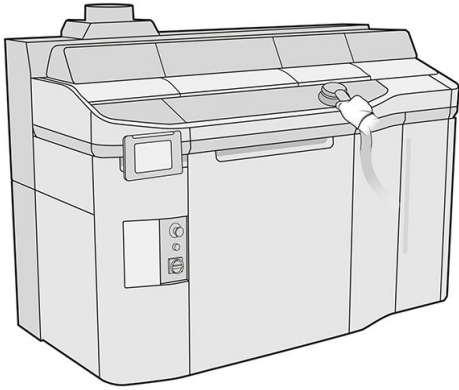

Additionally, you can wipe it with a dry cloth.

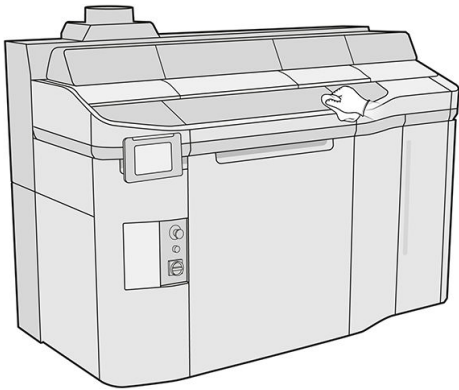

Clean the recoating roller and recoating plates

Prepare for cleaning

1. Ensure that the printer is not printing.
2. If a job has just been printed, wait about 20 minutes for the printer to cool down.
3. You are recommended to wear gloves.
4. Ensure that all windows, covers, and doors are closed and remain in their original positions.
5. Open the top cover.

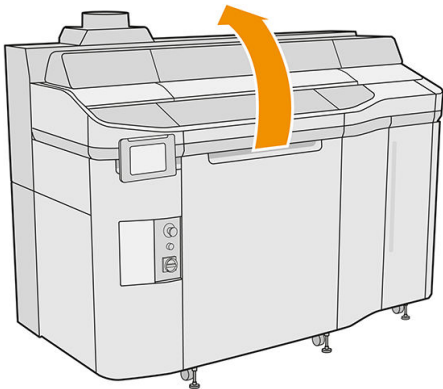

6. Remove the build unit from the printer, if it is present.
7. Move the recoating unit manually to the front, slowly and carefully.

Clean the recoating roller and recoating plates

1. Locate the recoating unit and use a flat screwdriver to remove four T15 screws.

⚠ CAUTION: Be careful not to drop the screws.

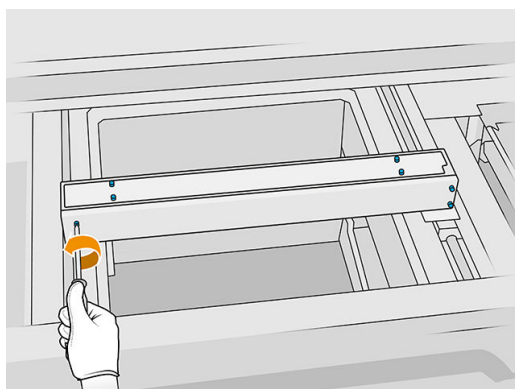

2. Remove the front lid.

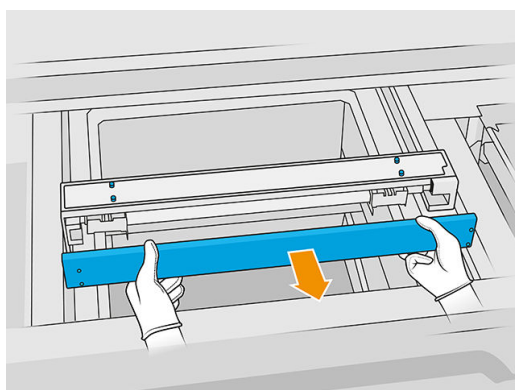

3. Remove four T10 screws (two on each side).

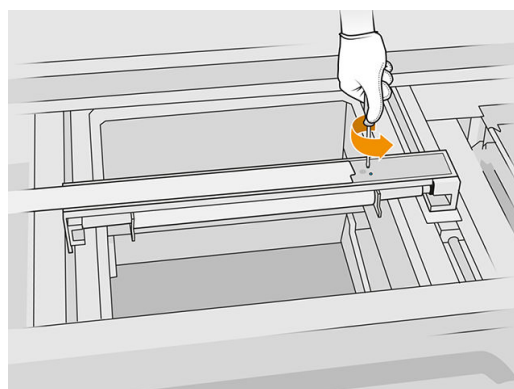
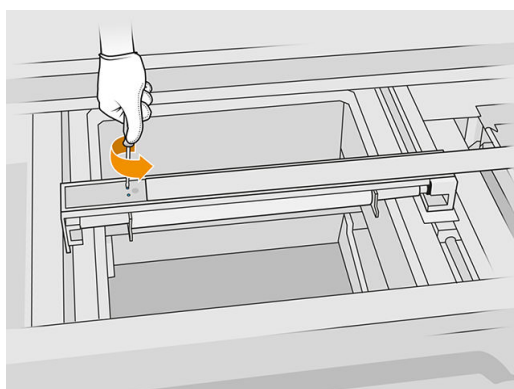

4. Remove the roller by pulling it towards you, and place it gently on a table or flat surface.

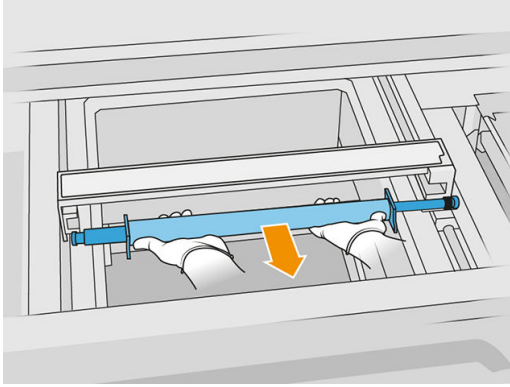

5. Use a lint-free cloth dampened with a general-purpose industrial cleaner, such as Simple Green industrial cleaner, to clean all along the recoating roller. Remove any remaining soap foam with a dry cloth.
6. Remove the recoating plates for easy cleaning, and clean them thoroughly, especially on the inner side.

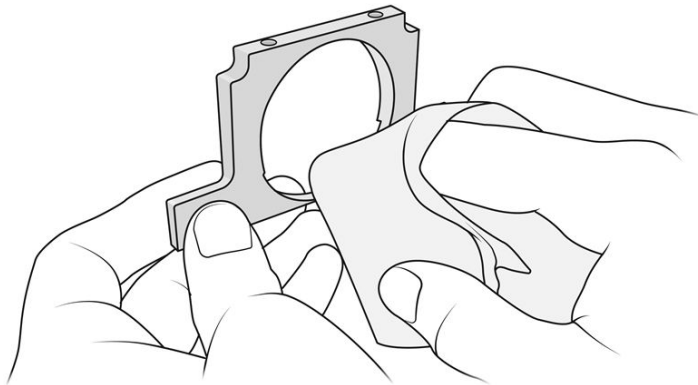

 **IMPORTANT:** No material should be left on the plate.



7. Clean the dust from the inside of the recoating unit, using an explosion-protected vacuum cleaner with a crevice nozzle. Place special attention to the right-hand side, where the gears are located.

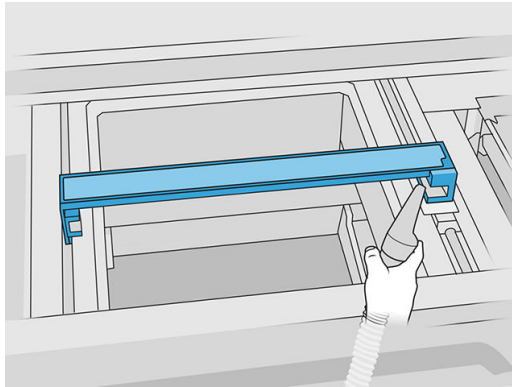

Finish cleaning

1. Put back both recoating plates.
2. Carefully reinsert the recoating roller by placing it and pushing it to the end.

 **NOTE:** The gears should be on the right when placing the roller.

3. Align the plates with the line as shown below.

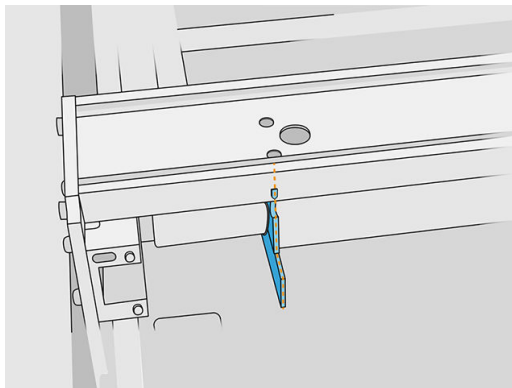

4. Secure the recoating roller with the top four screws.

 **TIP:** Hold the plate up while tightening the top screws.

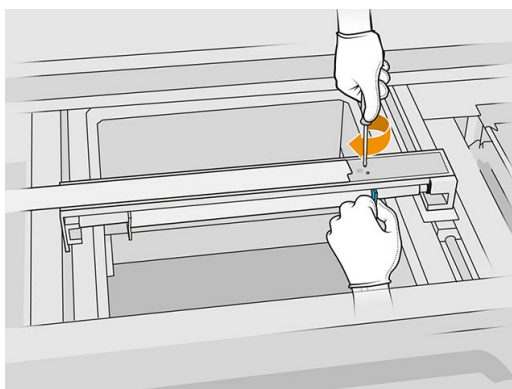

5. Put back the front lid of the recoating unit, but do not insert the screws yet.

6. Attach the lid with the four T15 screws.

 **IMPORTANT:** While tightening the screws on the right, smoothly rotate the roller in both directions to check that the gear teeth are properly engaged.

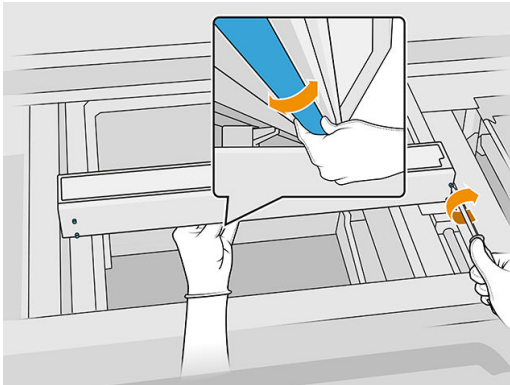

7. Close the top cover.
8. Ensure that all windows, covers, and doors are closed and remain in their original positions.

Clean the scan-axis wipers

Prepare for cleaning

1. Ensure that you have an explosion-protected vacuum cleaner and a screwdriver.
2. Ensure that the printer is not printing.
3. If a job has just been printed, wait about 20 minutes for the printer to cool down.
4. Turn off the printer.
5. You are recommended to wear gloves.

Clean the scan-axis wipers

1. Open the top cover to access the scan-axis wipers.

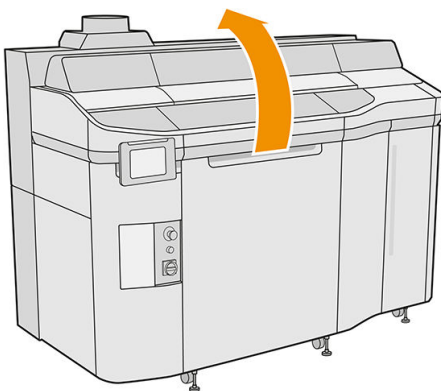

2. Locate the scan-axis wipers, one on each side.

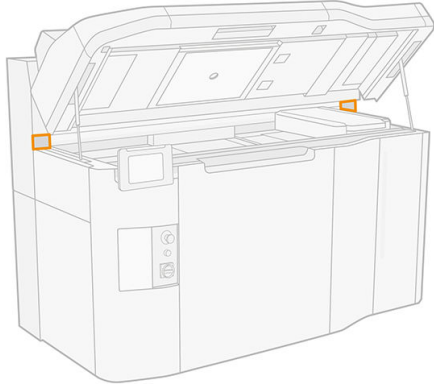

3. Remove two screws from each wiper, and remove the wipers.

⚠ CAUTION: Material can fall when you remove the wipers.

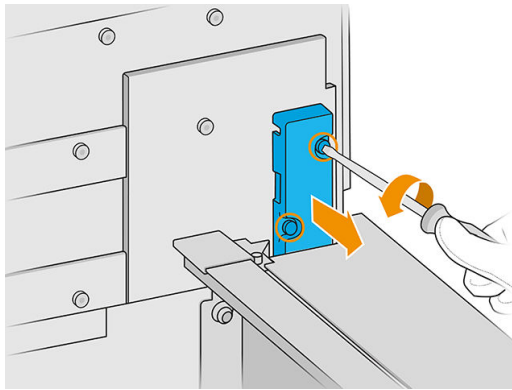

4. Vacuum the wiper hole until there is no material left in it.
5. Vacuum the wipers until there is no material left on them.

Finish cleaning

1. Put the wipers back in place, and fasten them with the screws.

⚠ CAUTION: If you print before putting back the wipers, material can fall outside the printer.

2. Close the top cover.
3. Ensure that all windows, covers, and doors are closed and remain in their original positions.
4. Turn on the printer.

Clean the inside of the carriage

Prepare for cleaning

1. Ensure that you have an explosion-protected vacuum cleaner (not provided by HP).
2. Ensure that the printer is not printing.
3. If a job has just been printed, wait about 20 minutes for the printer to cool down.
4. You are recommended to wear gloves and goggles.

5. Open the top cover.



Clean the inside of the carriage

1. Pull the print carriage handle to open the cover.

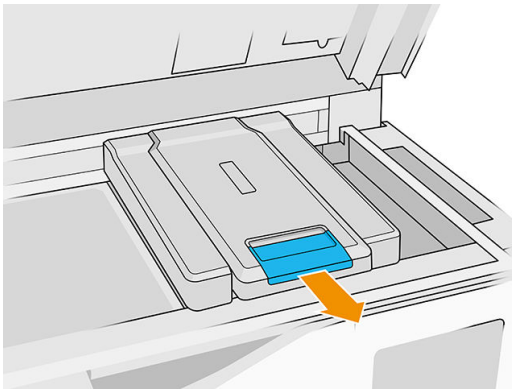

2. Remove the print carriage cover.

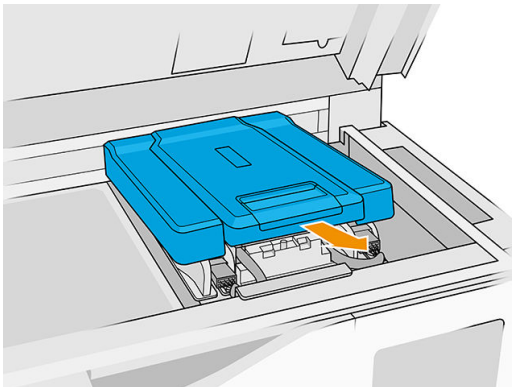

3. Vacuum inside the carriage, using an explosion-protected vacuum cleaner with a soft brush nozzle.

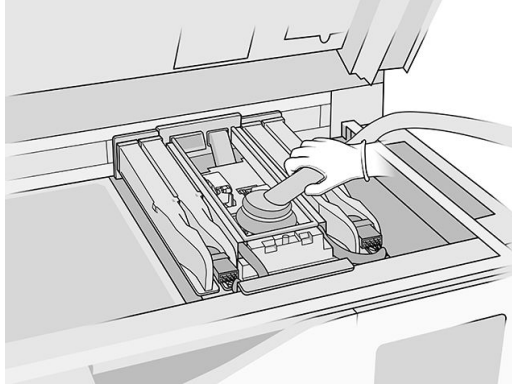

Finish cleaning

1. Put the print carriage cover back into place.
2. Close the top cover.

Clean the service-station caps

Prepare for cleaning

1. Ensure that you have a lint-free cloth and a general-purpose industrial cleaner, such as Simple Green industrial cleaner (these things are not provided by HP).
2. Ensure that the printer is not printing.
3. Turn off the printer.
4. If a job has just been printed, wait about 20 minutes for the printer to cool down.
5. You are recommended to wear gloves.
6. Open the top cover.

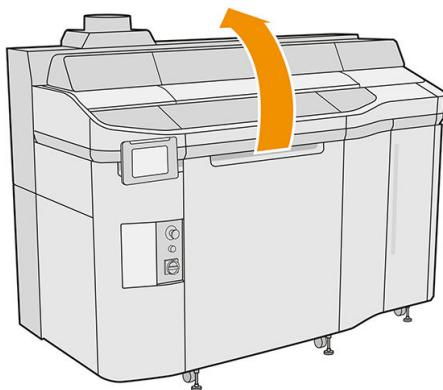

7. Move the print carriage manually to the left, slowly and carefully, to access the capping station.



Clean the service-station caps

1. Locate the three service-station caps to be cleaned.

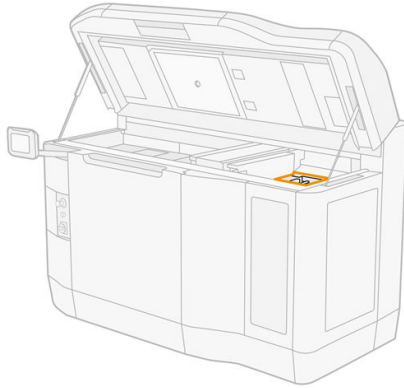

2. Clean the service-station caps using a lint-free cloth dampened with a general-purpose industrial cleaner, such as Simple Green industrial cleaner.

CAUTION: Take special care not to disengage the spring and not to pull any cap out of position.

3. Remove any remaining soap foam with a clean cloth moistened with deionized water.

Finish cleaning

1. Close the top cover.
2. Ensure that all windows, covers, and doors are closed and remain in their original positions.
3. Turn on the printer.

Clean the top-enclosure fan filters

Prepare to clean

1. Ensure that the printer is not printing.
2. If a job has just been printed, wait about 20 minutes for the printer to cool down.
3. You are recommended to wear gloves, goggles, and mask.

Clean the top-enclosure left and right fan filters

1. Open the top cover.

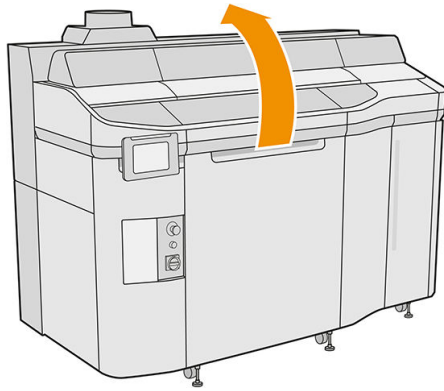

2. Locate the fan filters on the printer top cover at right and left.

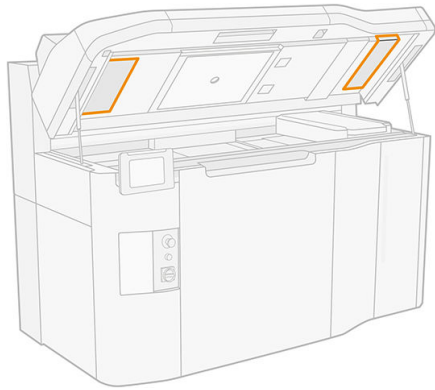

3. Unscrew the captive screws.

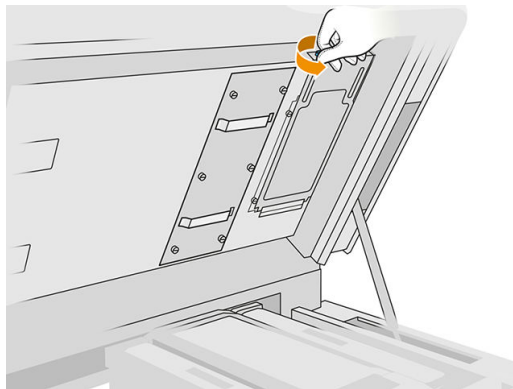

4. Remove the filter cover.

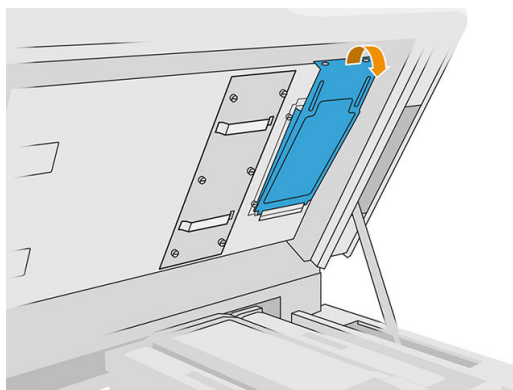

5. Remove each filter assembly, and take it somewhere with a non-explosive atmosphere.

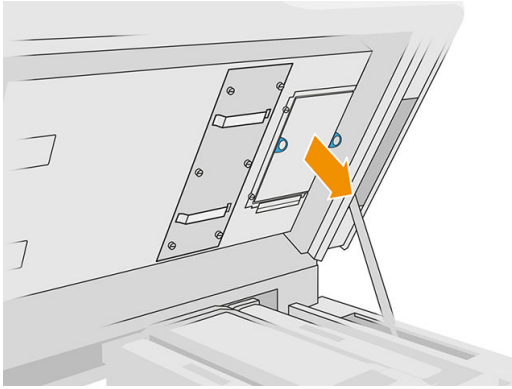

6. Position the filter flat over a hard surface with the airflow direction arrow pointing upwards. Then knock the filter gently against the hard surface until no material drops out of it.
7. Put each filter assembly back into the top enclosure (with the arrow pointing upwards) and tighten the screws.

Calibrate the cooling system

- ▲ At the front panel, tap , then **Maintenance > Cooling system calibration**.

Clean the front bar

Prepare for cleaning

1. Ensure that you have an absorbent all-purpose cloth (not provided by HP).
2. Ensure that the printer is not printing.
3. Turn off the printer.
4. If a job has just been printed, wait about 20 minutes for the printer to cool down.
5. You are recommended to wear gloves.

Clean the front bar

1. Open the top cover.

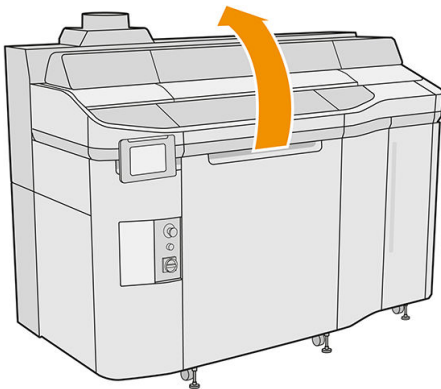

2. Clean the front bar using a lint-free cloth dampened with deionized water.

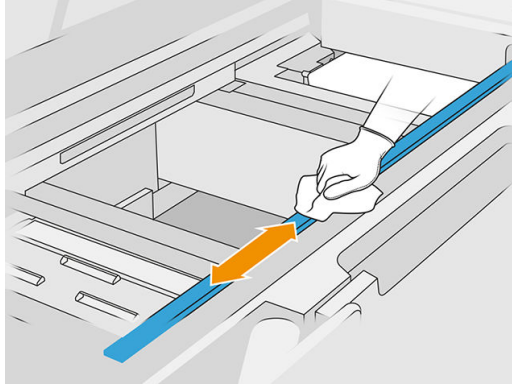

3. Move the carriage manually and slowly in order to clean the part of the bar underneath the carriage.

Finish cleaning

1. Close the top cover.
2. Ensure that all windows, covers, and doors are closed and remain in their original positions.

Clean the material extraction system

1. Locate the material extraction system doors on both sides of the printer, and choose one to start with.

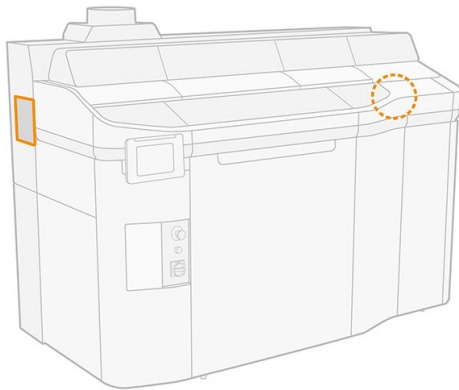

2. Unscrew the two screws.

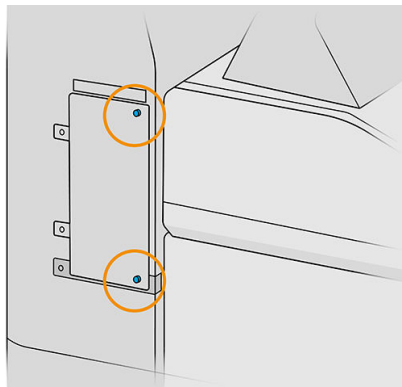

3. Open the door.

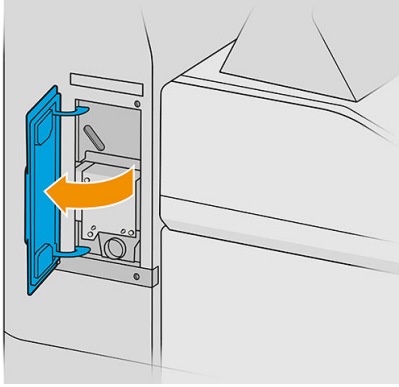

4. Plug the explosion-protected vacuum cleaner into the material extraction hole, and turn it on for 10 s.
5. Close the door.
6. Put back and tighten the two screws.
7. Repeat the process with the other door.

Clean the fusing-lamp glasses

Prepare for cleaning

1. Ensure that you have a lint-free cloth, a general-purpose industrial cleaner (such as Simple Green industrial cleaner), and a scourer (these things are not provided by HP).
2. Ensure that the printer is not printing.
3. If a job has just been printed, wait about 20 minutes for the printer to cool down.
4. You are recommended to wear gloves.
5. Ensure that all windows, covers, and doors are closed and remain in their original positions.
6. Turn off the printer.
7. Open the top cover.

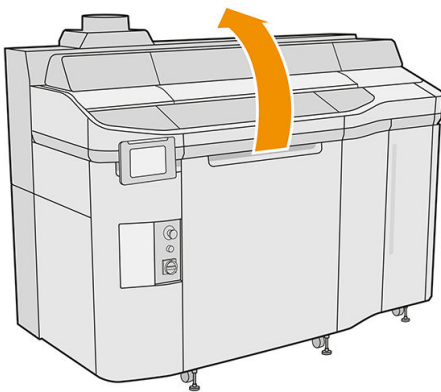

8. Move the print carriage manually over the build unit space, slowly and carefully.



Risk of burns



Crush hazard



Risk of trapped fingers



Hazardous moving
part



Light radiation hazard



Electric shock hazard

For more safety information, see [Safety precautions on page 5](#)

Remove the fusing-lamp module

1. Identify which of the two lamps requires cleaning.

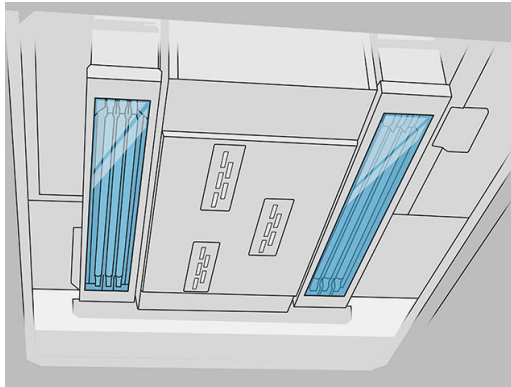

2. Pull the print carriage handle to open the cover.

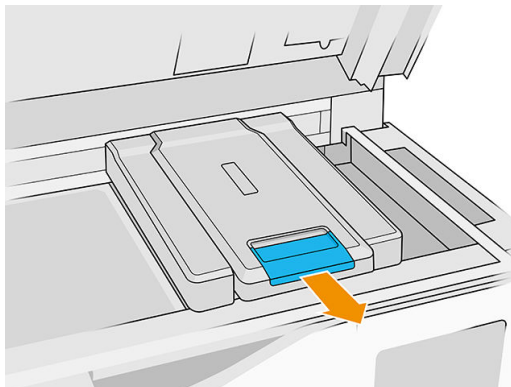

3. Remove the print carriage cover.

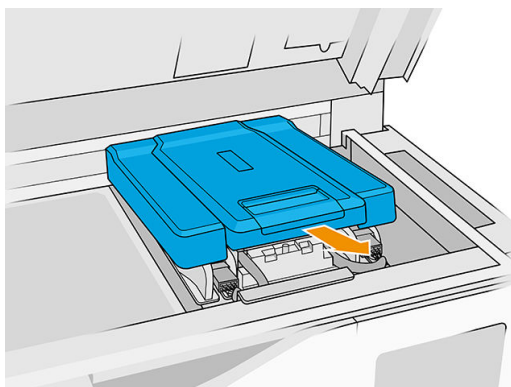

4. Unscrew the captive screw at the front of the fusing module.

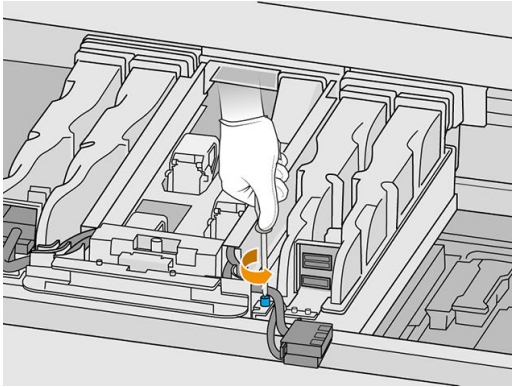

5. Pull the fusing-lamp assembly sideways and then toward you.

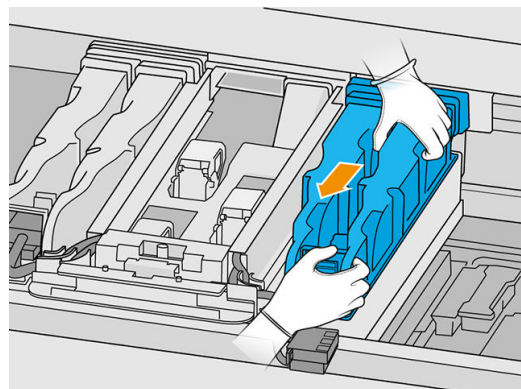
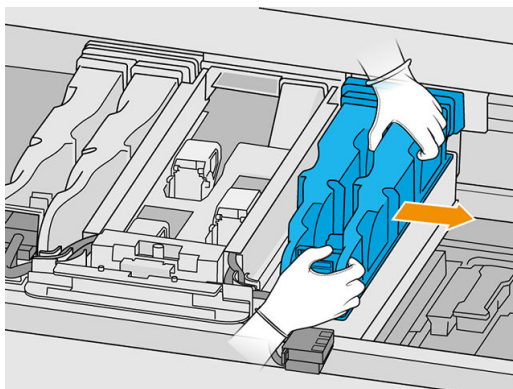

6. Take the fusing-lamp module out of the carriage and place it gently on a table.

Safety precautions for the fusing-lamp emitter

- Disregard of the safety precautions or improper operation of the infrared emitter can lead to injuries and material damage.
- The IR heating device should be operated only by specialists or trained personnel.
The operator of the system should compile specific instructions for personnel training.
- The safety and functional reliability of the IR heating device are guaranteed only if you are using original accessories and spare parts from HP.
- After an emitter break, a dangerous voltage may be exposed to contact by the heating spiral.
- The reflector side should not be cleaned.

Clean the fusing-lamp glasses

1. Turn the assembly upside down and unscrew the four screws of the exterior glass frame.

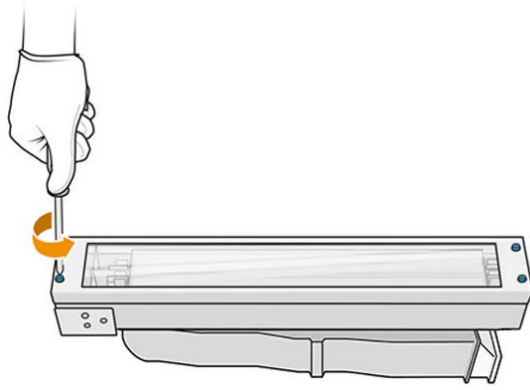

2. Carefully remove the frame of the exterior glass.

⚠ CAUTION: When you remove the frame, the glass may stick to it. Take care that the glass does not fall out of the frame as you pick it up.

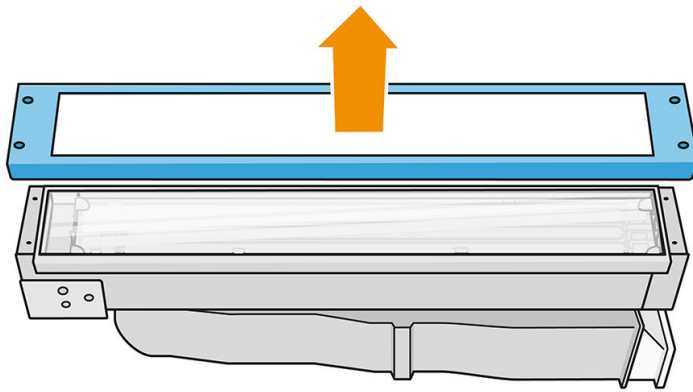

3. Remove the exterior glass and place it gently on a table or other flat surface.

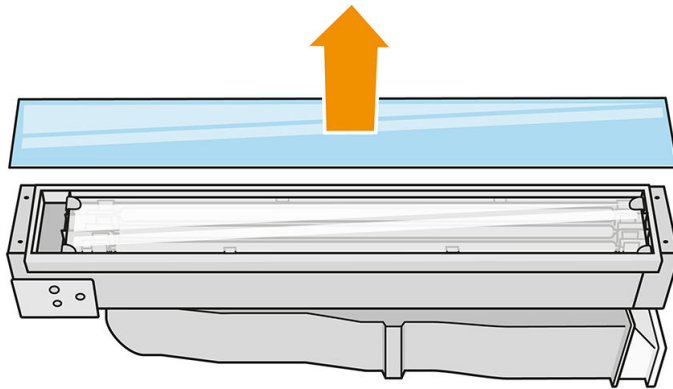

4. Moisten both sides of the glass with a lint-free cloth dampened with a general-purpose industrial cleaner, such as Simple Green industrial cleaner. Remove any remaining soap foam with a lint-free cloth dampened with distilled water, and dry it with a dry cloth.

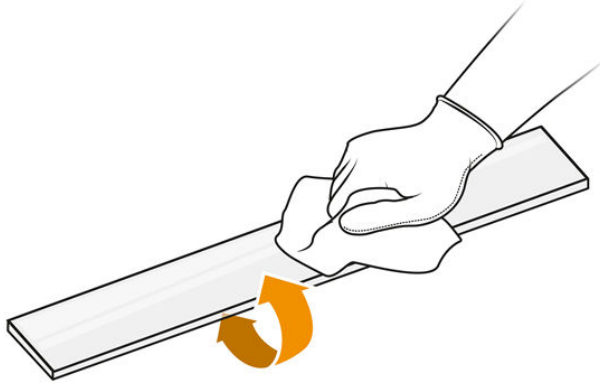

5. Continue cleaning until the glass is clean.
If there is some plastic or material fused to the glass, clean it with a scourer.
6. Clean the frame using the same damp cloth.
7. Push the metallic clip and remove the internal glass.
8. Moisten both sides of the internal glass with a lint-free cloth dampened with a general-purpose industrial cleaner, such as Simple Green industrial cleaner. Remove any remaining soap foam with a dry cloth.

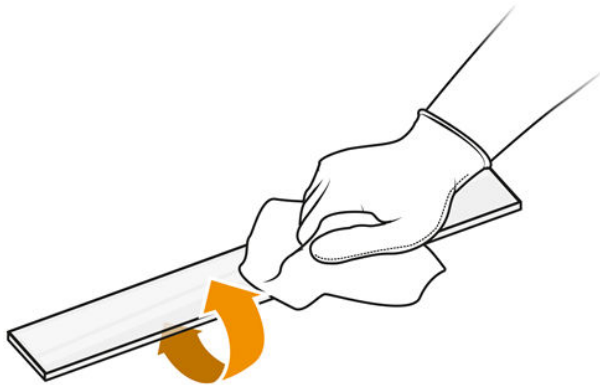

9. Continue cleaning until the glass is clean.
If there is some plastic or material fused to the glass, dispose of the glass and insert a new glass: see [Replace a fusing-lamp internal glass on page 192](#).

Reassemble the lamp glasses

1. Insert the internal glass into the two rear brackets, and pull the front of the metallic clip to insert the other side.
2. Add the bottom glass and then the frame, securing it with four screws.

Reassemble the fusing-lamp module

1. Turn the assembly upside down and put it back into the print carriage.
2. Tighten the captive screw.
3. Plug in the black power connector.

4. Plug in the gray sensor connector.
5. Put back the cover.

Finish cleaning

1. Close the top cover.
2. Ensure that all windows, covers, and doors are closed and remain in their original positions.
3. Turn on the printer.

Clean the bottom glass of the heating lamps

Prepare for cleaning

1. Ensure that you have a lint-free cloth, a general-purpose industrial cleaner (such as Simple Green industrial cleaner), and a scourer (these things are not provided by HP).
2. Ensure that the printer is not printing.
3. If a job has just been printed, wait about 20 minutes for the printer to cool down.
4. You are recommended to wear gloves and safety goggles.
5. Ensure that all windows, covers, and doors are closed and remain in their original positions.

Remove the bottom glass of the heating lamps

1. Open the top cover.

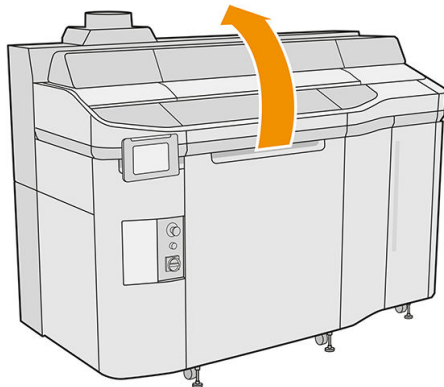

2. Locate the bottom glass of the heating lamps.

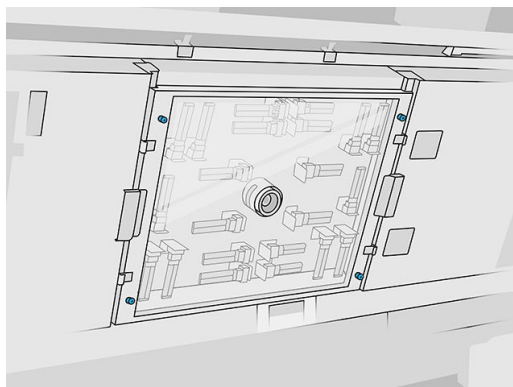

3. Unscrew the four captive screws to remove the bottom glass.

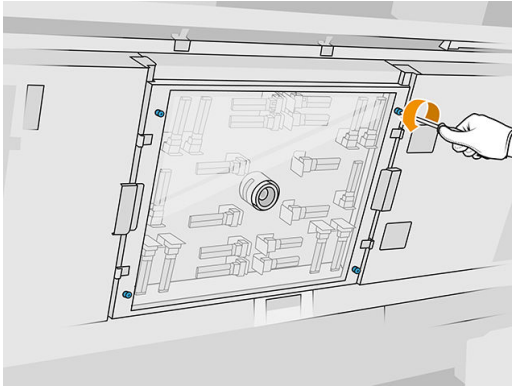

4. Pull the bottom glass out of the top cover and place it gently on a table.

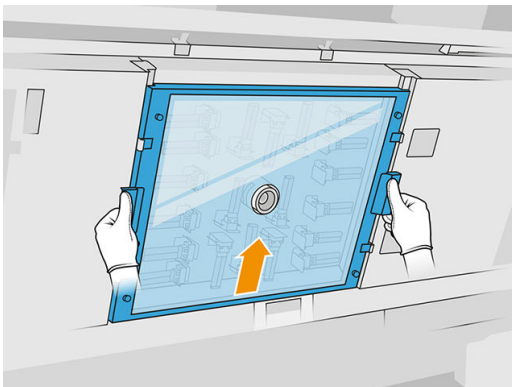

Clean the bottom glass of the heating lamps

1. Moisten both sides of the glass with a lint-free cloth dampened with a general-purpose industrial cleaner, such as Simple Green industrial cleaner. Remove any remaining soap foam with a lint-free cloth dampened with distilled water, and dry it with a dry cloth.

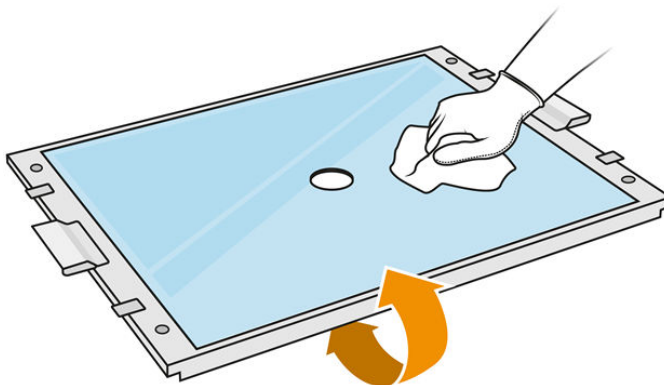

2. Scrub both sides of the glass with the scourer.
3. Continue cleaning with cloth and scourer until the glass is clean.

Reinstall the bottom glass of the heating lamps

1. Put back the bottom glass in the correct position.
2. Tighten the four captive screws.
3. Ensure that the cleaned parts are completely dry and all vapor has completely evaporated before proceeding.

Finish cleaning

1. Close the top cover.
2. Ensure that all windows, covers, and doors are closed and remain in their original positions.
3. Turn on the printer.

Clean the recoater's left box and left rod

Prepare for cleaning

1. Ensure that the printer is not printing.
2. If a job has just been printed, wait about 20 minutes for the printer to cool down.
3. You are recommended to wear gloves.
4. Ensure that all windows, covers, and doors are closed and remain in their original positions.
5. Remove the build unit from the printer.
6. Turn off the printer.



Risk of burns



Crush hazard



Risk of trapped fingers



Hazardous moving part



Light radiation hazard



Electric shock hazard

For more safety information, see [Safety precautions on page 5](#)

Clean the recoater's left box and left rod

1. Open the build-unit door.

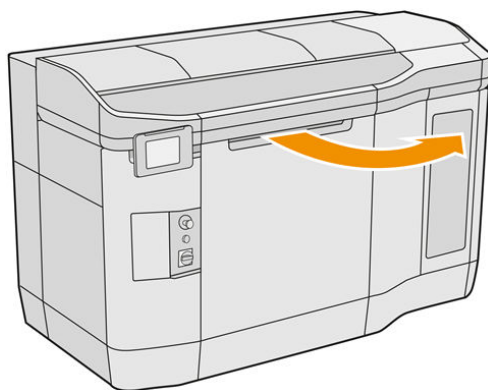

2. Locate the recoater's left box.

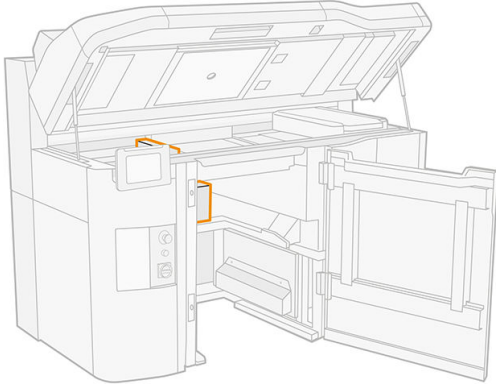

3. Remove the ten screws, and remove the cover.

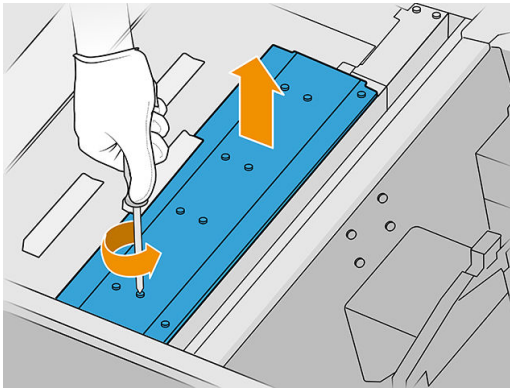

4. Remove the eight screws to open the recoater's left box.

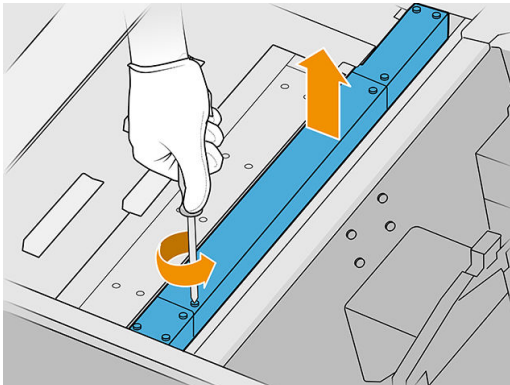

5. Clean the dust from the recoater's left box, using an explosion-protected vacuum cleaner with a narrow nozzle.

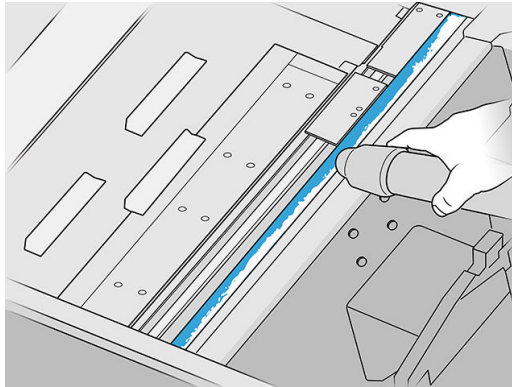

6. Wipe the left rod with a lint-free cloth dampened with a general-purpose industrial cleaner, such as Simple Green industrial cleaner. Remove any remaining soap foam with a dry cloth.
7. Continue cleaning with the cloth until the rod is clean.

Finish cleaning

1. Put back the front sheet metal, restoring the screws.
2. Close the build-unit door.
3. Close the top cover.
4. Ensure that all windows, covers, and doors are closed and remain in their original positions.
5. Turn on the printer.

Clean the printhead contacts

Prepare for cleaning

1. Ensure that you have several dry cloths, a general-purpose industrial cleaner (such as Simple Green industrial cleaner), and deionized water.
2. Ensure that the printer is not printing.
3. If a job has just been printed, wait about 20 minutes for the printer to cool down.
4. You are recommended to wear gloves.
5. If the build unit is in the printer, remove it.

Open covers

1. At the printer's front panel, tap , then **Printheads > Replace**.

2. Open the top cover.

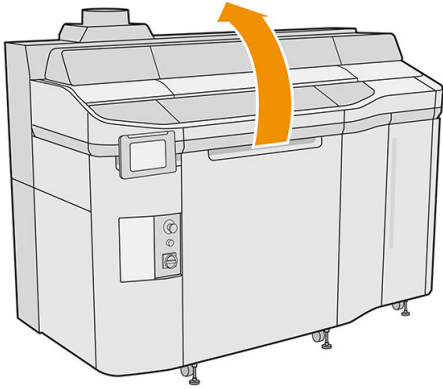

3. Pull the print-carriage handle to open its cover.

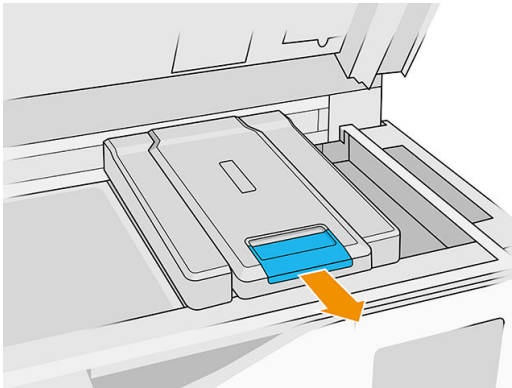

4. Lift the print-carriage cover.

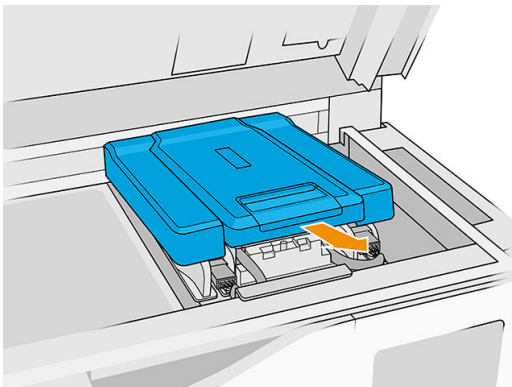

Clean the printhead contacts in the carriage

1. Carefully remove the three printheads from the carriage. See [Replace a printhead on page 44](#).
2. Turn off the printer.
3. Move the print carriage manually over the build unit space, slowly and carefully.
4. Illuminate the printhead slot in the carriage and check the electrical connections to the printhead for dirt.



5. Clean the right side of the printhead slot (not the side with the contacts) with a soft brush, such as a toothbrush.

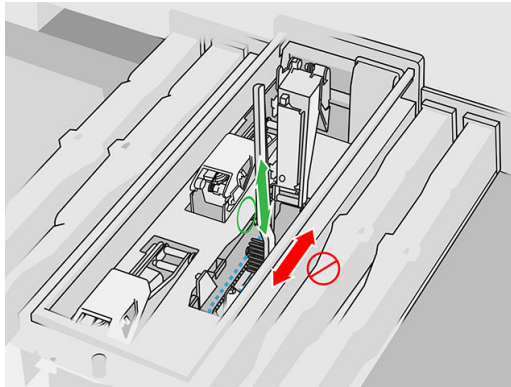

6. Wipe the printhead contacts with a lint-free cloth moistened with a general-purpose industrial cleaner (such as Simple Green industrial cleaner), moving it up and down (not side to side). Remove any remaining soap foam with a clean cloth dampened with deionized water.

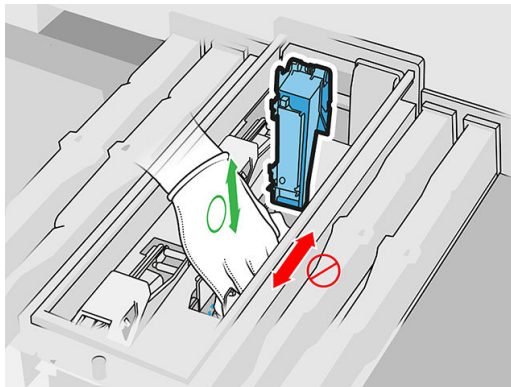

7. Illuminate the printhead slot again to check that the electrical connections are now clean and undamaged.

Clean the printhead contacts on the printhead

1. Place the printheads on a table.
2. Clean the parts of the printhead away from the contacts with a soft brush; and then with a cloth moistened with water.
3. Clean the contact side of the printhead with a lint-free cloth moistened with a general-purpose industrial cleaner, such as Simple Green industrial cleaner. Remove any remaining soap foam with a clean cloth dampened with deionized water.

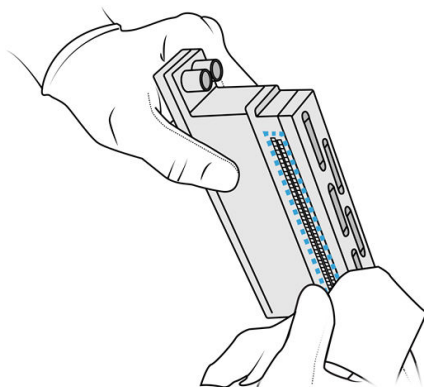

4. Clean the printhead nozzles with a different cloth moistened with deionized water.

⚠ CAUTION: Make sure to use deionized water and not the industrial cleaner for this step.

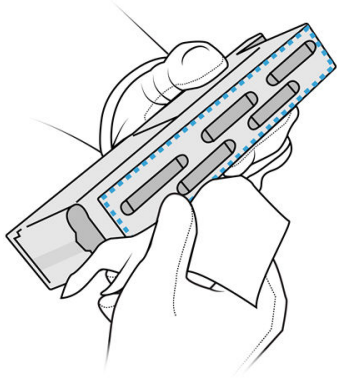

5. Wipe the printhead dry with a similar but dry cloth.

Finish cleaning

1. Wait until the contacts and other parts are dry.
2. Put back the print carriage cover.
3. Close the top cover.
4. Ensure that all windows, covers, and doors are closed and remain in their original positions.
5. Turn on the printer.
6. Start a printhead replacement from the front panel to reinsert the printheads in the normal way. See [Replace a printhead on page 44](#).
7. Align the printheads. See [Align the printheads on page 230](#).

Clean the print-zone window

Prepare for cleaning

1. Ensure that you have an absorbent all-purpose cloth.
2. Ensure that the printer is not printing.
3. If a job has just been printed, wait about 20 minutes for the printer to cool down.
4. You are recommended to wear gloves.
5. Ensure that all windows, covers, and doors are closed and remain in their original positions.

Clean the print-zone window

1. Open the top cover.

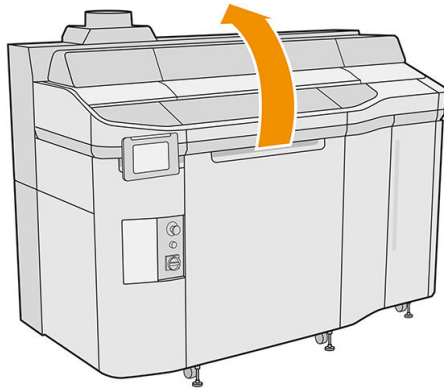

2. Locate the print-zone window.

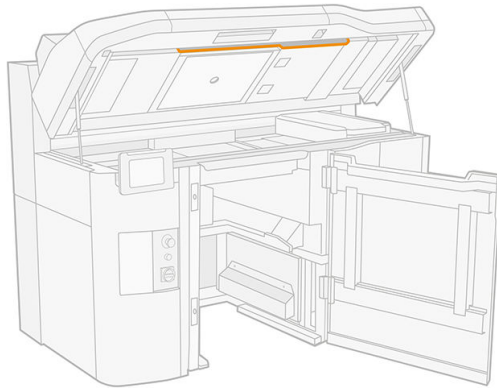

3. Wipe the glass with an absorbent all-purpose cloth dampened with deionized water.

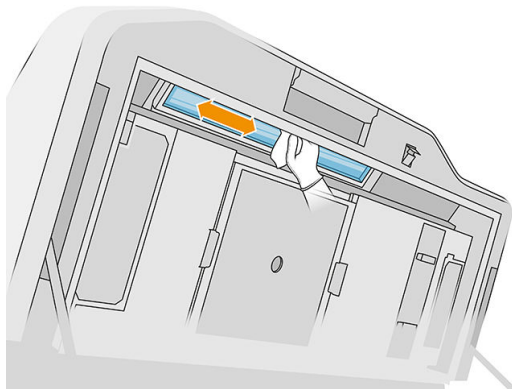

4. Close the top cover and clean the external part of the print-zone window.

Replace the heating-lamp filter

Prepare for replacement

1. Heating-lamp filters are provided with your printer in the printer yearly maintenance kit.
2. Ensure that the printer is not printing.
3. If a job has just been printed, wait about 20 minutes for the printer to cool down.
4. You are recommended to wear gloves and mask.
5. Ensure that all windows, covers, and doors are closed and remain in their original positions.
6. Turn off the printer.



Risk of burns



Crush hazard



Risk of trapped fingers



Hazardous moving part



Light radiation hazard



Electric shock hazard

For more safety information, see [Safety precautions on page 5](#)

Replace the heating-lamp filter

1. Open the top cover.

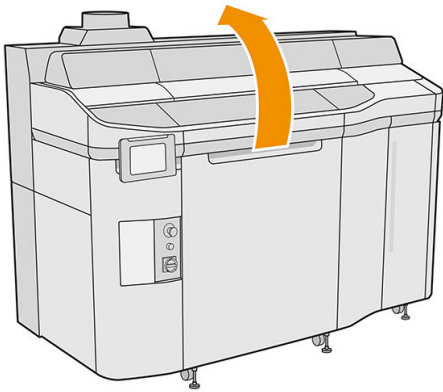

2. Locate the heating-lamp filter at the right of the top cover.

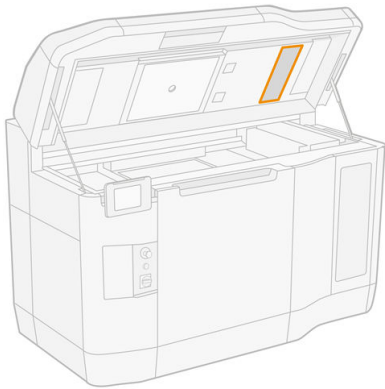

3. Remove the six screws and slide out the filter assembly.

⚠ CAUTION: The filter will fall out unless you hold it.

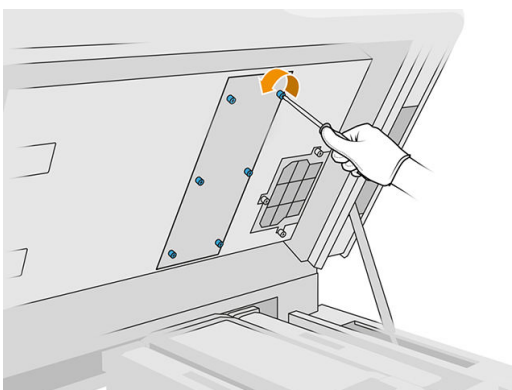

- Slide the filter out of its frame.

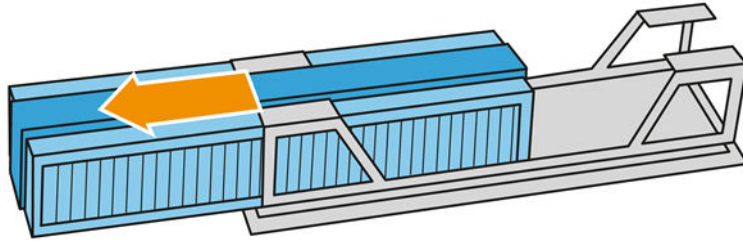

- Remove and dispose of the old filter according to local regulations.
- Insert the new filter into its frame.
- Put back the filter grid and tighten its six screws.

Finish the replacement

- Close the top cover.
- Ensure that all windows, covers, and doors are closed and remain in their original positions.
- Turn on the printer.

Replace the e-cabinet filter

Prepare for replacement

- Replacement filters are provided with your printer in the printer yearly maintenance kit.
- Ensure that the printer is not printing.
- If a job has just been printed, wait about 20 minutes for the printer to cool down.
- You are recommended to wear gloves, mask, and safety goggles.
- Ensure that all windows, covers, and doors are closed and remain in their original positions.
- Remove the build unit from the printer.
- Turn off the printer.



Risk of burns



Crush hazard



Risk of trapped fingers



Hazardous moving
part



Light radiation hazard



Electric shock hazard

For more safety information, see [Safety precautions on page 5](#)

Replace the e-cabinet filter

- Locate the e-cabinet filter.

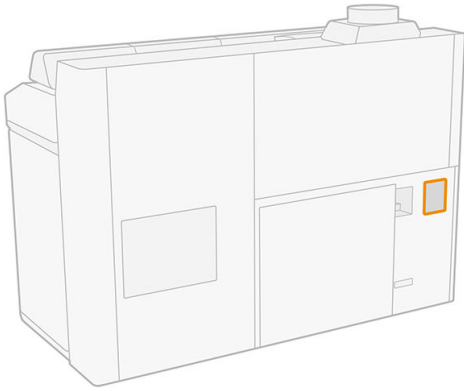

2. Unscrew four screws and remove the plastic filter cover.

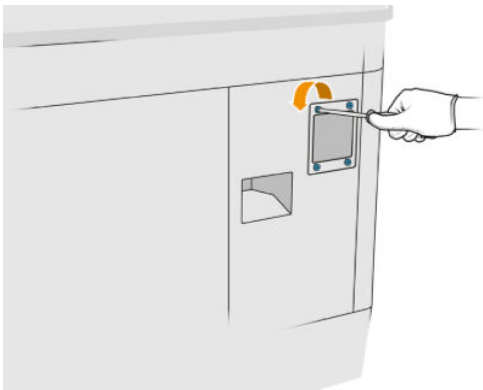

3. Remove and dispose of the old filter according to local regulations, and insert the new one.

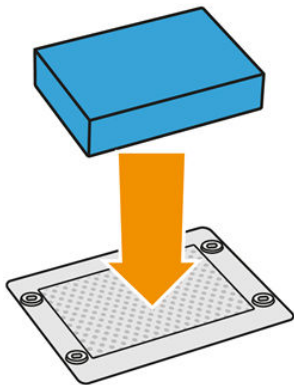

4. Carefully put back the filter cover and secure it with the screws.

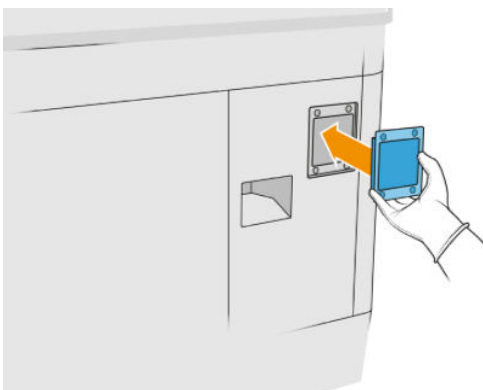

Finish replacement

1. Ensure that all windows, covers, and doors are closed and remain in their original positions.
2. Turn on the printer.

Replace the power-box fan filters

Prepare for replacement

1. Replacement fan filters are provided with your printer in the printer yearly maintenance kit. Only one set of filters is needed for this operation.
2. Ensure that the printer is not printing.
3. If a job has just been printed, wait about 20 minutes for the printer to cool down.
4. You are recommended to wear gloves, mask, and goggles.
5. Ensure that all windows, covers, and doors are closed and remain in their original positions.
6. Remove the build unit from the printer.
7. Turn off the printer.



Risk of burns



Crush hazard



Risk of trapped fingers



Hazardous moving part



Light radiation hazard



Electric shock hazard

For more safety information, see [Safety precautions on page 5](#)

Replace the power-box fan filters

1. Open the build-unit door.
2. Locate the power-box left fan filter and loosen the four captive screws.

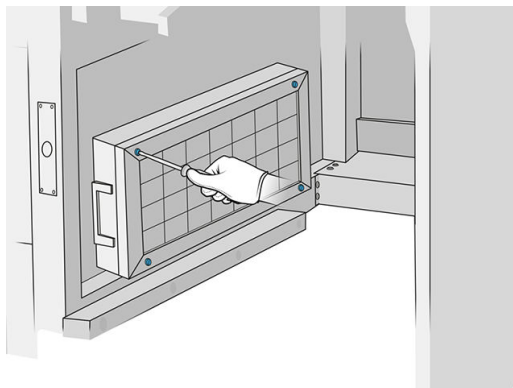

3. Remove the filter grid.

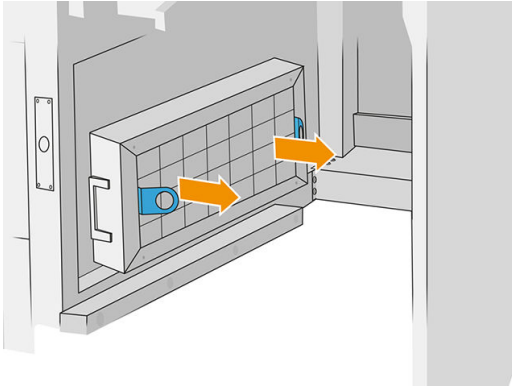

4. Remove and dispose of the old filter and insert the new one.
5. Put back the filter grid and tighten the screws.
6. Locate the power-box right fan filter.

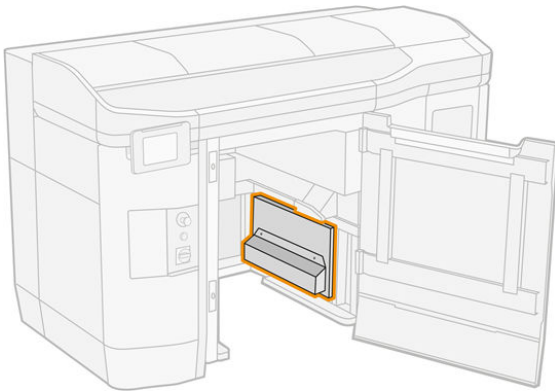

7. Loosen the two captive screws and remove the filter case.

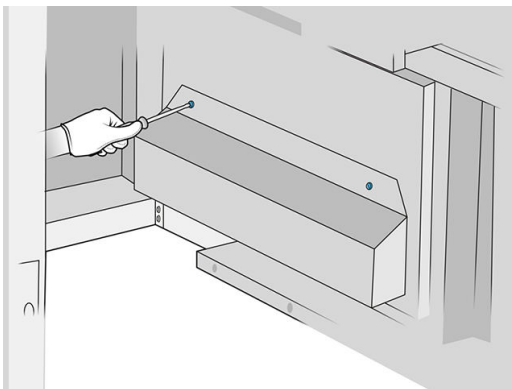

8. Remove and dispose of the old filter and insert the new one.

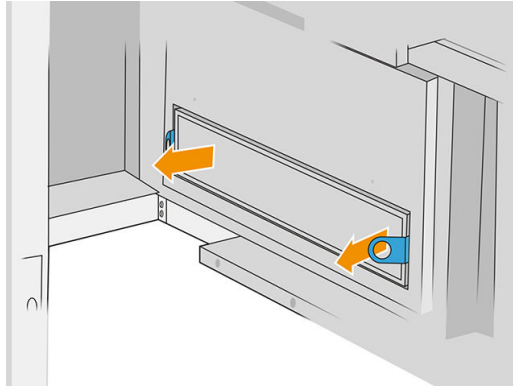

9. Put back the filter case and tighten the screws.

Finish replacement

1. Ensure that all windows, covers, and doors are closed and remain in their original positions.
2. Turn on the printer.

Replace the print-zone filter

Prepare for replacement

1. Print-zone filters are provided with your printer in the printer yearly maintenance kit. Sets of two filters are provided; only one filter is needed for this operation.
2. Ensure that the printer is not printing.
3. If a job has just been printed, wait about 20 minutes for the printer to cool down.
4. You are recommended to wear gloves and mask.
5. Ensure that all windows, covers, and doors are closed and remain in their original positions.
6. Turn off the printer.



Risk of burns



Crush hazard



Risk of trapped fingers



Hazardous moving
part



Light radiation hazard



Electric shock hazard

For more safety information, see [Safety precautions on page 5](#)

Replace the print-zone filter

1. Locate the fan filters at the rear left of the printer.

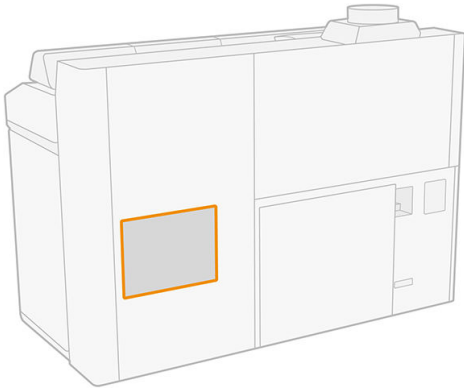

2. Remove eight screws, then remove the grid.

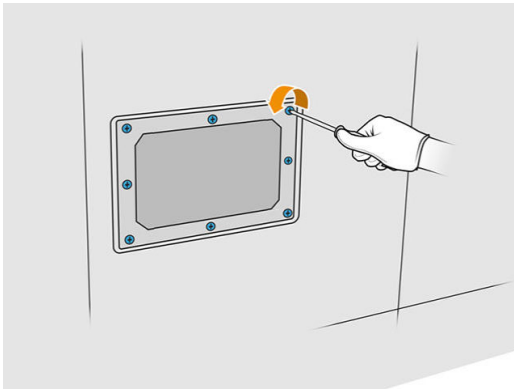

3. Pull the filter out of the frame and dispose of it according to local regulations.

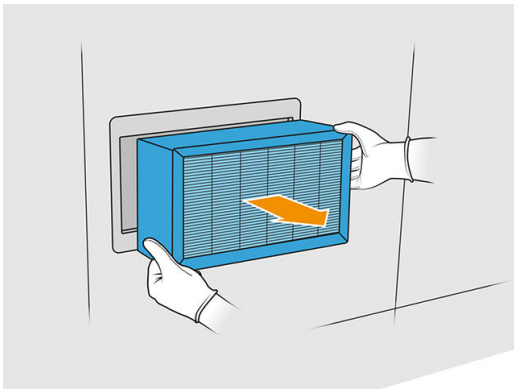

4. Insert the new filter provided in the kit.
5. Put back the filter grid and its screws.

Finish the replacement

1. Ensure that all windows, covers, and doors are closed and remain in their original positions.
2. Turn on the printer.
3. At the front panel, tap , then **Maintenance > Replace filters > Print zone**.

Replace the top-enclosure left and right fan filters

Replace the right or left top-enclosure filter when requested by the front panel. Tap , then **Other supplies**

> **Replace.**

Prepare to replace

1. Top-enclosure left and right fan filters are provided with your printer in the printer initial maintenance kit. Only one set of filters is needed for this operation.
2. Ensure that the printer is not printing.
3. If a job has just been printed, wait about 20 minutes for the printer to cool down.
4. You are recommended to wear goggles and mask.

Replace the top-cover left and right fan filters

1. Open the top cover.

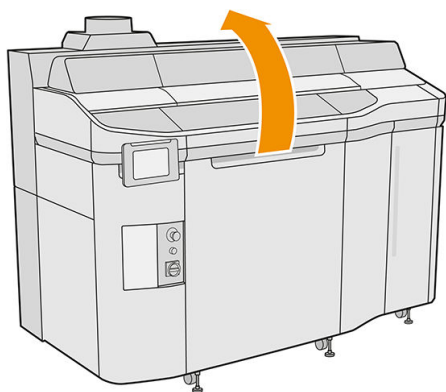

2. Locate the fan filters on the printer top cover at right and left.

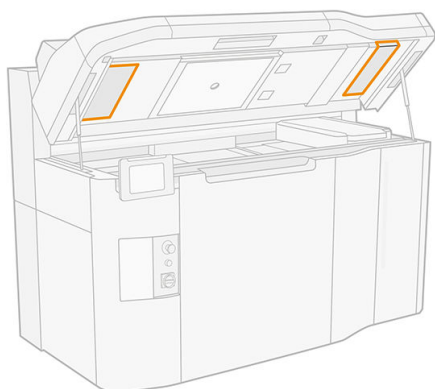

3. Unscrew the captive screws.

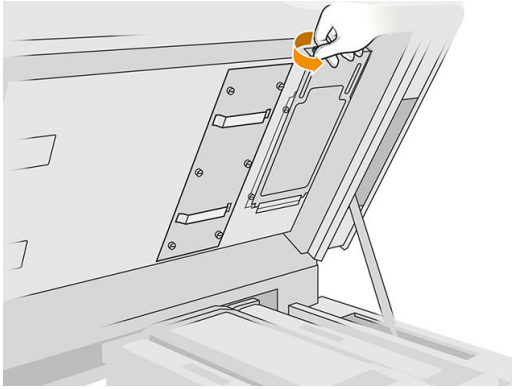

4. Remove the filter cover.

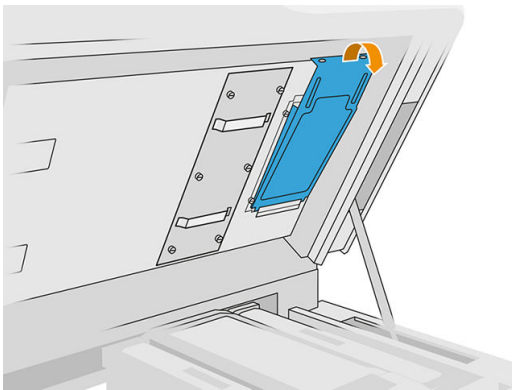

5. Remove each filter and dispose of it according to your local laws.

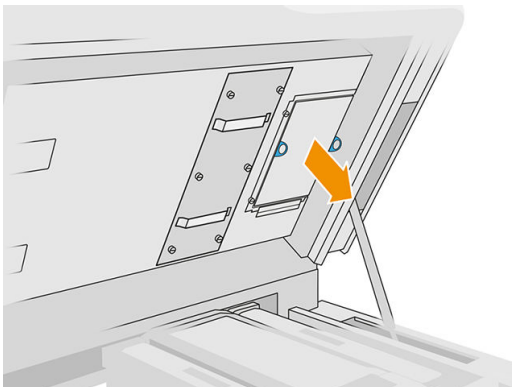

6. Put each filter back into its corresponding place in the top cover (with the arrow pointing upwards), place the filter cover, and tighten the screws.

Replace a primer

Prepare for replacement

1. Ensure that you have the primers and latch kit.
2. Ensure that the printer is not printing.
3. If a job has just been printed, wait about 20 minutes for the printer to cool down.
4. You are recommended to wear gloves and goggles.

5. Ensure that all windows, covers, and doors are closed and remain in their original positions.
6. Turn off the printer.



Risk of burns



Crush hazard



Risk of trapped fingers



Hazardous moving
part



Light radiation hazard



Electric shock hazard

For more safety information, see [Safety precautions on page 5](#)

Open covers

1. Open the top cover.

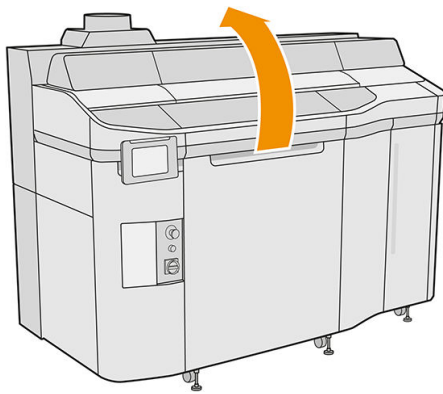

2. Pull the print-carriage handle to open its cover.

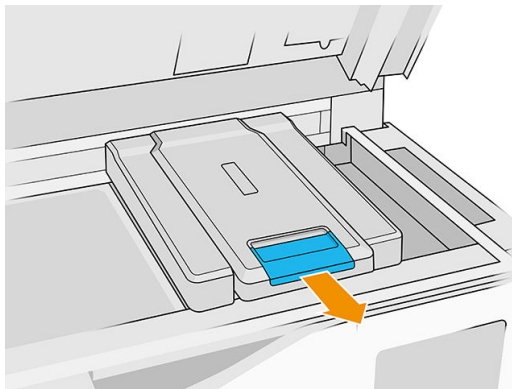

3. Remove the print-carriage cover.

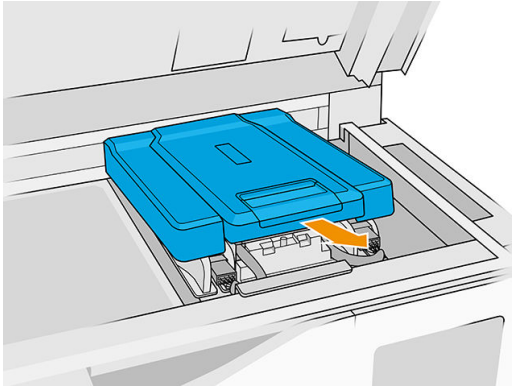

Replace a primer

1. Disconnect the primer cable, by disconnecting the white connector that you can find at the left side of the printhead whose primer is to be replaced.

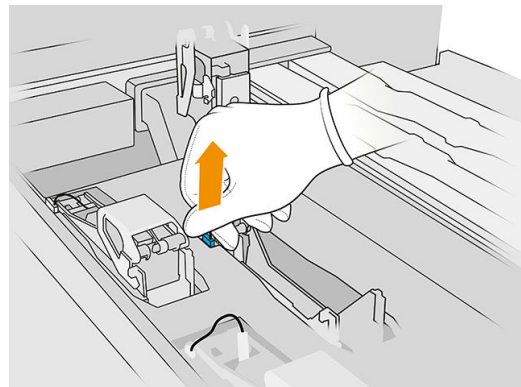
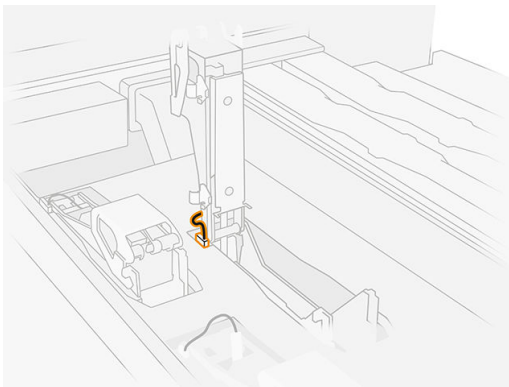

2. Open the printhead latch. It is not usually necessary to remove the printhead.

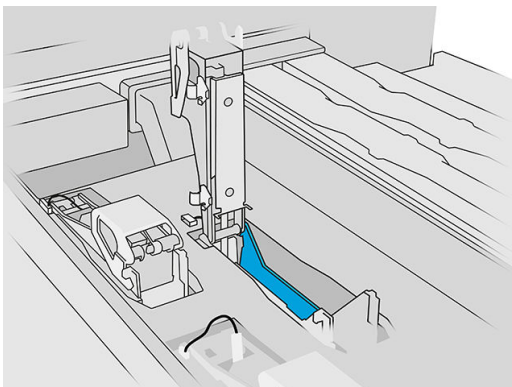

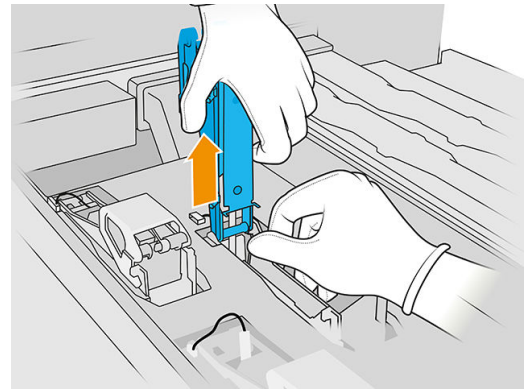
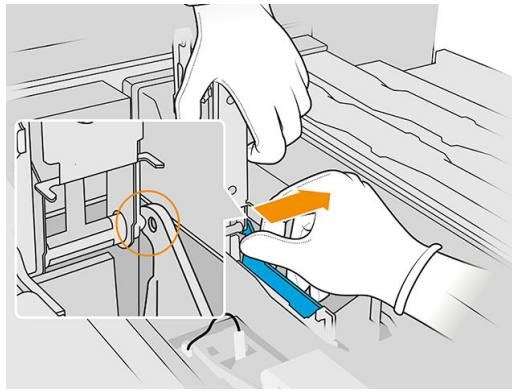

3. Remove the old latch and dispose of it according to local regulations.



4. Connect the new latch primer cable.
5. Install the new latch with the primer.
6. Check that the new latch can move freely through the whole stroke.
7. Close the new latch.

Finish the replacement

1. Close the print-carriage cover.
2. Close the top cover.
3. Ensure that all windows, covers, and doors are closed and remain in their original positions.
4. Turn on the printer.
5. At the front panel, tap , then **System tools** > **Primer utilities** > **Primer check**, to test the primer functionality.
6. Tap , then **Maintenance** > **Printer reset counter** > **Reset printhead primer counter**, to reset the usage of the replaced primer to zero.

Replace a service-station cap module

Prepare for replacement

1. Ensure that you have the service station caps kit.
2. Ensure that the printer is not printing.
3. If a job has just been printed, wait about 20 minutes for the printer to cool down.
4. You are recommended to wear gloves and goggles.
5. Ensure that all windows, covers, and doors are closed and remain in their original positions.
6. Move the print carriage manually to the left, slowly and carefully, to access the capping station.

Replace a service-station cap module

1. Open the top cover to access the capping station.

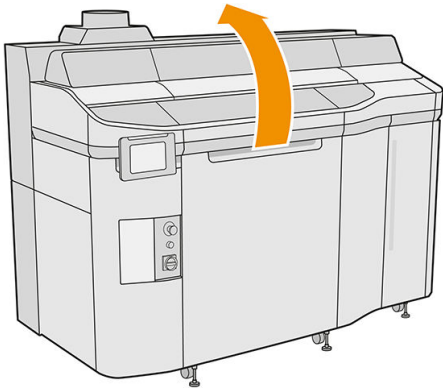

2. Remove the service-station cap, by pushing both snaps at the same time and rotating the cap about the y axis. Dispose of the old cap according to local regulations.

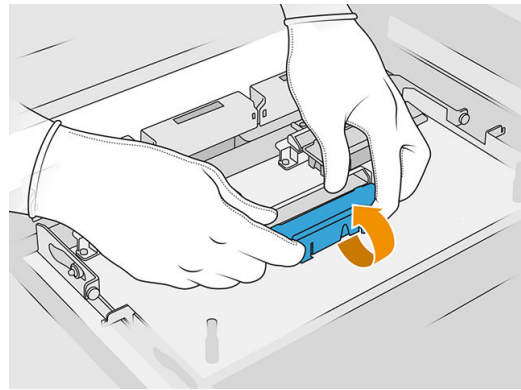
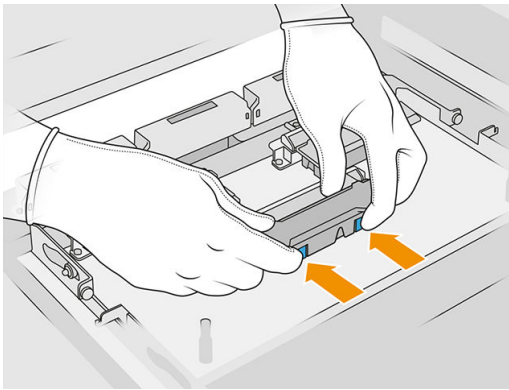

3. Place the new cap.

Finish the replacement

1. Close the top cover.
2. Ensure that all windows, covers, and doors are closed and remain in their original positions.
3. At the front panel, tap , then **System tools > Printer reset counter > Service-station cap replacement**.

Rubber-blade height adjustment

Purpose of the adjustment

The printhead cleaning roll's rubber-blade height adjustment is intended to adjust the distance between the rubber blade and the printheads to its correct value. Too large a distance causes defective cleaning and lower printhead life, while too small a distance causes mechanical problems and excessive rubber-blade wear.

When to perform the adjustment

Use of the rubber blade gradually wears it down until it requires readjustment. The printer monitors the situation, and shows an alert in the following cases:

- **Rubber blade mid-life:** The rubber blade is worn but still usable. Perform the height adjustment to maintain correct operation.

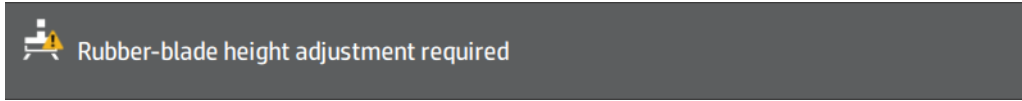

- **Rubber blade end of life:** The rubber blade should be replaced by a new one. See [Replace the printhead cleaning roll's rubber blade on page 181](#).

The height of the new blade will need adjusting, so you should also perform the height adjustment in this case.

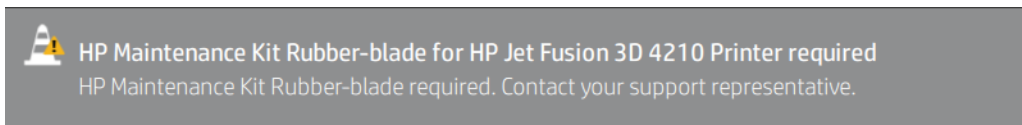

Adjustment procedure

1. At the front panel, tap , then **System tools > Calibrations > Rubber-blade height adjustment**.

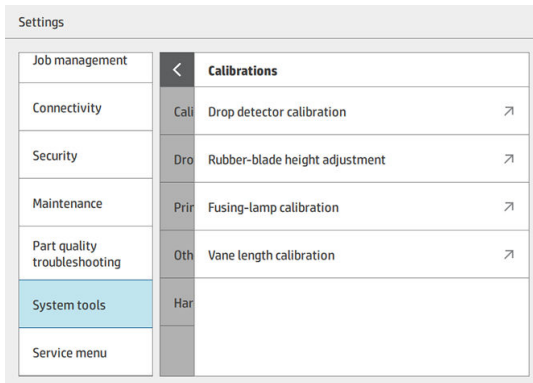

2. Close the top cover and rearm the printer if necessary.

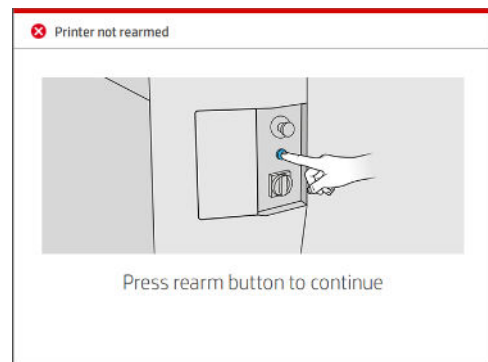

3. When you see the question, **Do you want to perform the wiper height and tilt adjustment?**, tap **OK**.

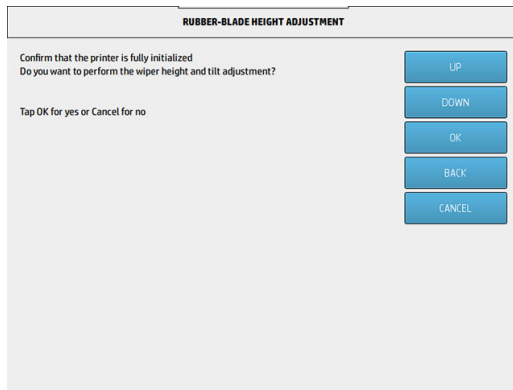

4. The printer prints a pattern on the cleaning roll. This pattern is coarse, but it gives a rough idea of the rubber-blade height. When prompted, open the cover to evaluate the pattern.

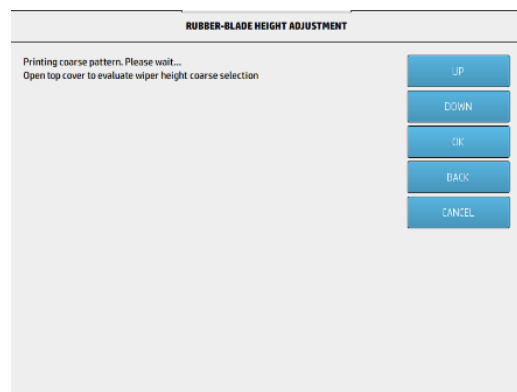
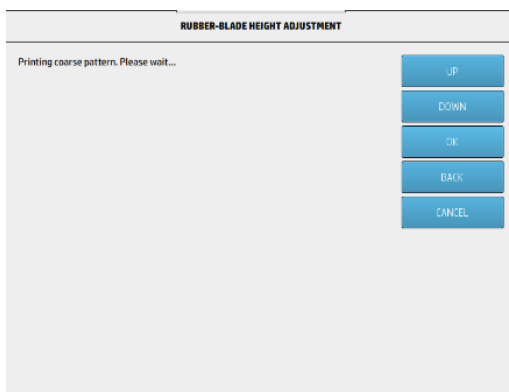

5. Look at the lines at the right side of the pattern (blue box) and, from right to left, count the number of **complete lines**, which may range from 0 to 9. In the example below, the number is 1.

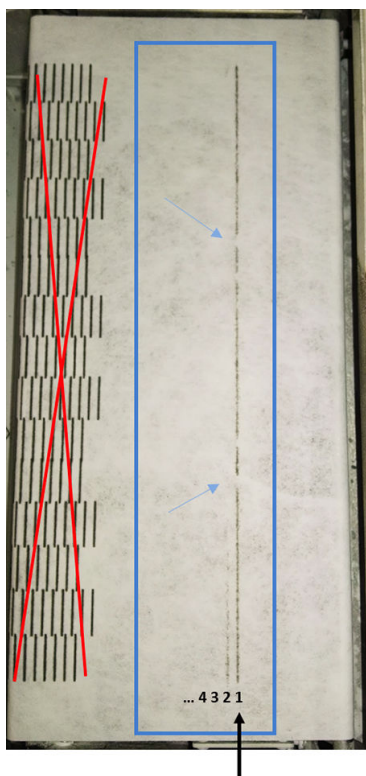

 **NOTE:** A line is complete if it extends across the width of the roll. Such a line should be counted even if it contains short breaks, as indicated above by blue arrows.

6. Use the **UP** and **DOWN** keys on the front panel to enter the number of complete lines, and tap **OK** to continue.

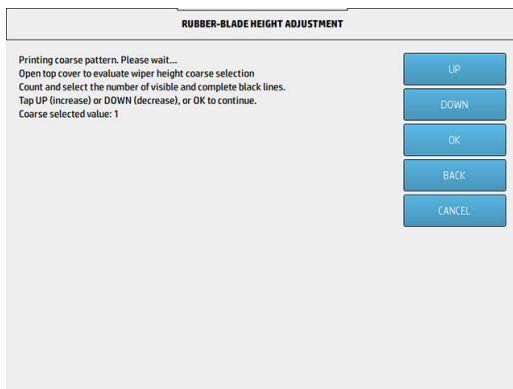

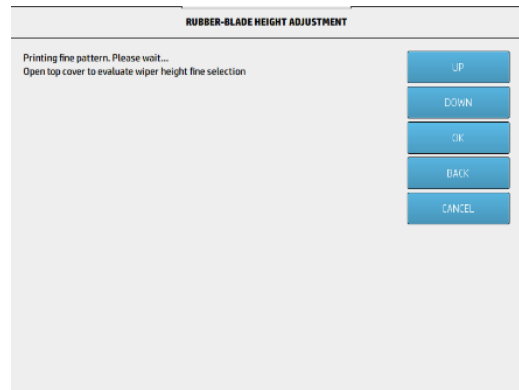
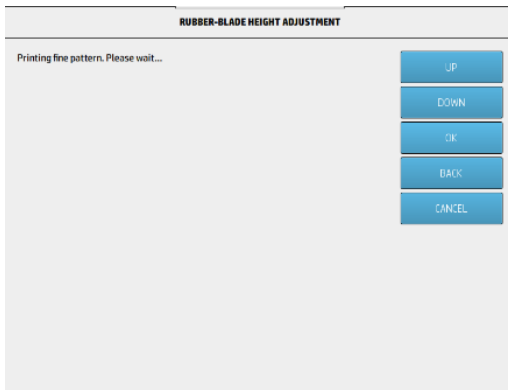

7. The printer prints a second pattern on the cleaning roll. This pattern is finer, designed to fine-tune the adjustment. When prompted, open the cover to evaluate the pattern.

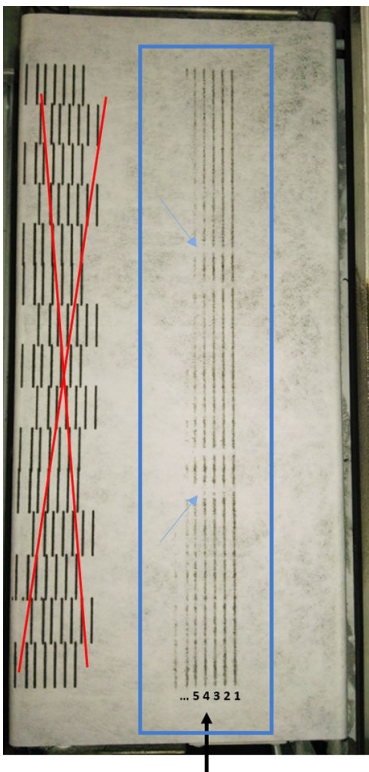

8. Once again, look at the lines at the right side of the pattern (blue box) and, from right to left, count the number of complete lines, which may range from 0 to 7. In the example below, the number is 4.



 **NOTE:** A line is complete if it extends across the width of the roll. Such a line should be counted even if it contains short breaks, as indicated above by blue arrows.

 **IMPORTANT:** If you see no complete lines in this fine-tuning adjustment, so that you have to enter the number 0 (zero), the adjustment will fail. In this case, contact your support representative.

- Use the **UP** and **DOWN** keys on the front panel to enter the number of complete lines, and tap **OK** to continue.

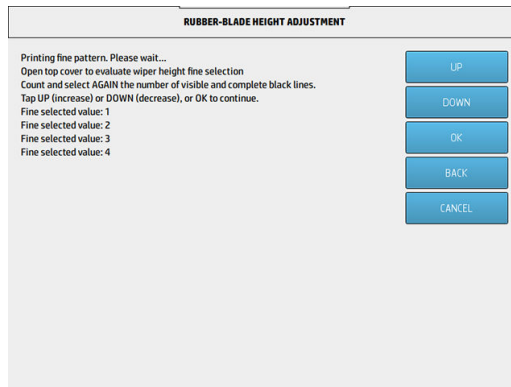

- On reaching the final screen, tap **OK** to complete the adjustment procedure.

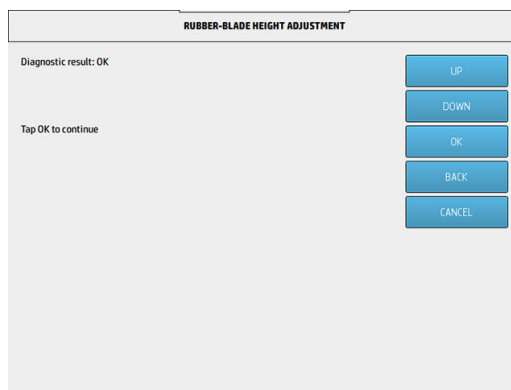

Replace the printhead cleaning roll's rubber blade

Prepare for replacement

- Ensure that you have the printhead cleaning roll rubber blade kit, which is included in the printer initial maintenance kit, but can also be purchased separately.
- Ensure that the printer is not printing.
- If a job has just been printed, wait about 20 minutes for the printer to cool down.
- You are recommended to wear gloves and goggles.
- Open the agent door and the external cleaning-roll door.

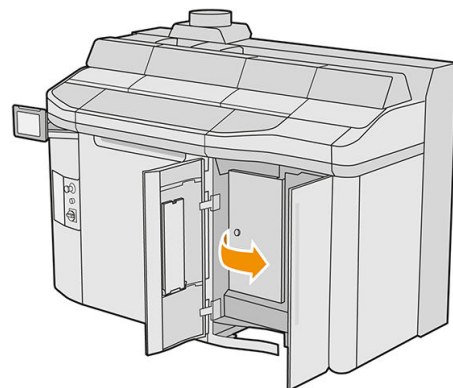
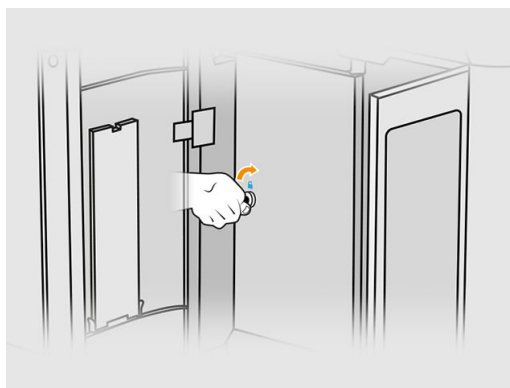

6. Open the top cover.
7. Pull the black knob at the top left and move the pinch system aside.



8. Move the printhead cleaning material aside to uncover the rubber blade.

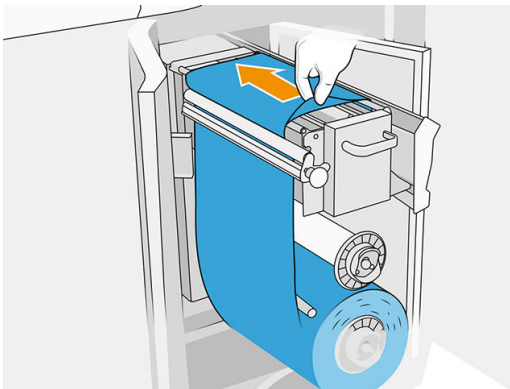

Replace the rubber blade

1. Use a Torx 15 screwdriver to remove two screws. While you unscrew them, you must hold the two spacers on the inside (otherwise, they will fall and might get lost).

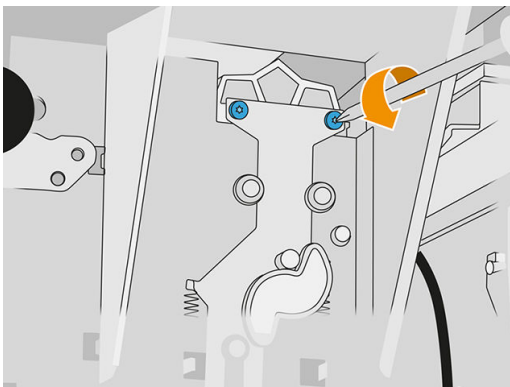

2. Remove the two spacers. Be careful not to lose them!

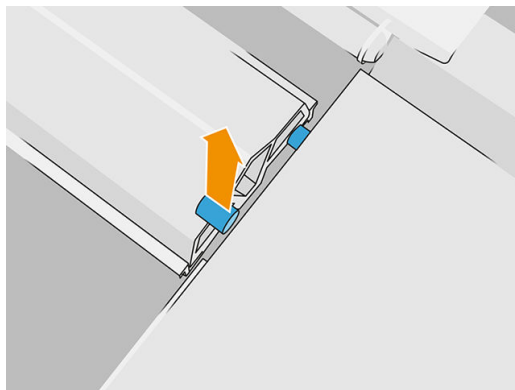

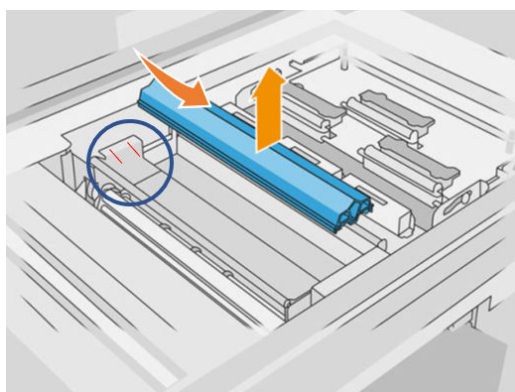

3. Pull out the old rubber blade from the two pins at the back, then remove and dispose of it according to local regulations.



4. Insert the new rubber blade, carefully aligning the two pins at the back.
5. At the front, reinsert and tighten each screw with one hand, while holding the spacer on the other side with the other hand.

Finish the replacement

1. Push the printhead cleaning material back into place, and close the pinch system (using the black plastic knob).
2. Close the printhead cleaning roll door and agent door.
3. At the front panel, tap , then **System tools > Printer reset counter > Reset rubber blade counter**.
4. Tap , then **System tools > Calibrations > Rubber-blade height adjustment**.

See [Rubber-blade height adjustment on page 176](#) for more details.

Replace a service-station drop-detector module

Prepare for replacement

1. Ensure that you have the service-station drop-detectors kit.
2. Ensure that the printer is not printing.
3. If a job has just been printed, wait about 20 minutes for the printer to cool down.

4. You are recommended to wear gloves and goggles.
5. Ensure that all windows, covers, and doors are closed and remain in their original positions.
6. Move the print carriage manually to the left, slowly and carefully, to access the capping station.
7. Turn off the printer.



Risk of burns



Crush hazard



Risk of trapped fingers



Hazardous moving part



Light radiation hazard



Electric shock hazard

For more safety information, see [Safety precautions on page 5](#)

Replace a service-station drop-detector module

1. Open the agent door and the external cleaning-roll door.

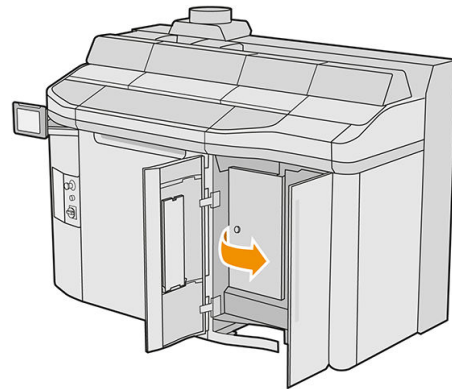
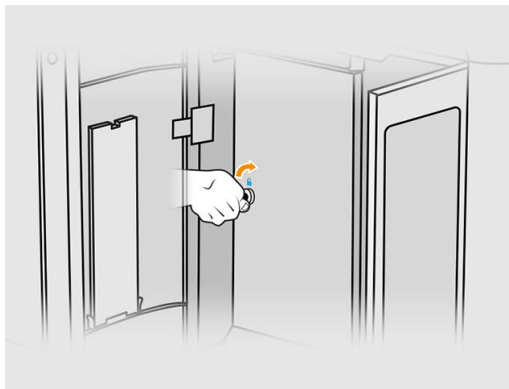

2. Locate the drop-detector cable to be replaced.

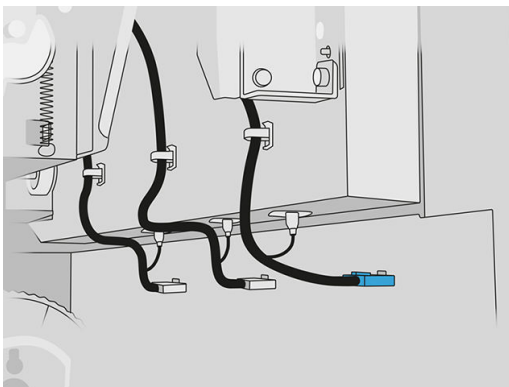

3. Disconnect the drop-detector cable from both connectors.

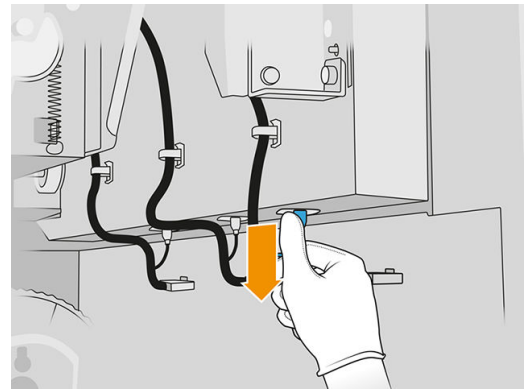
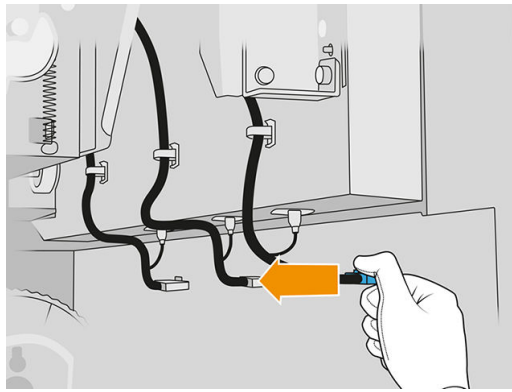

4. Remove the cable from its holder.

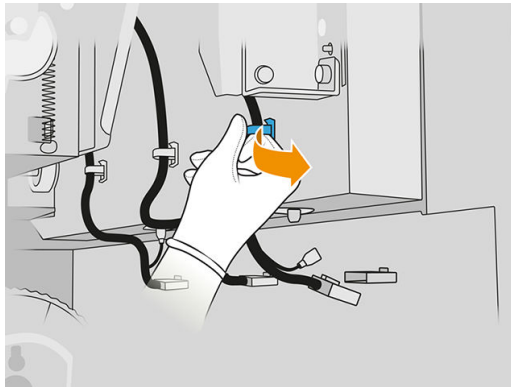

5. Open the top cover to access the drop-detection station.

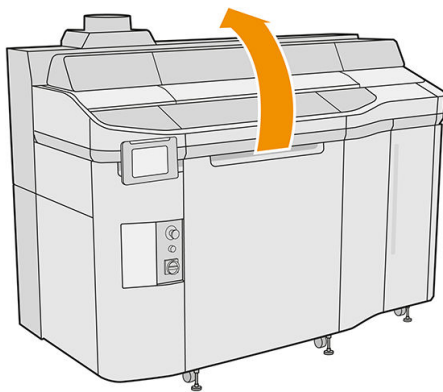

6. Use a Torx screwdriver to remove the screw.

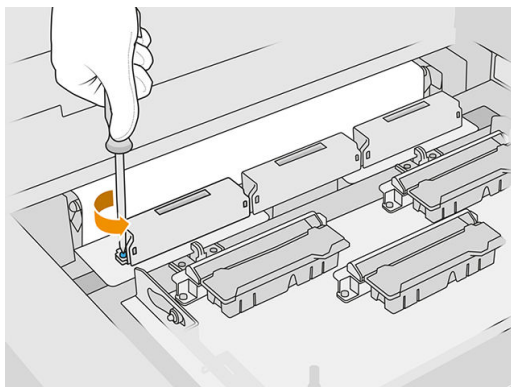

7. Rotate and remove the old drop detector, and dispose of it according to local regulations.

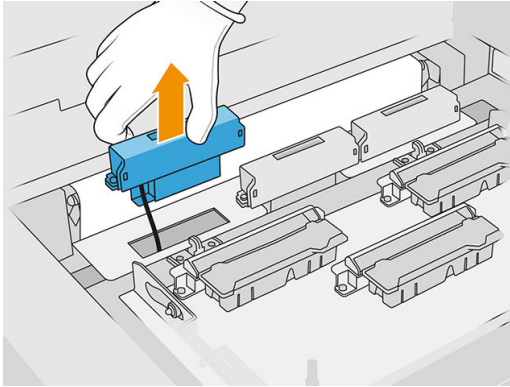

8. Perform the same operations in reverse to install the new drop detector.

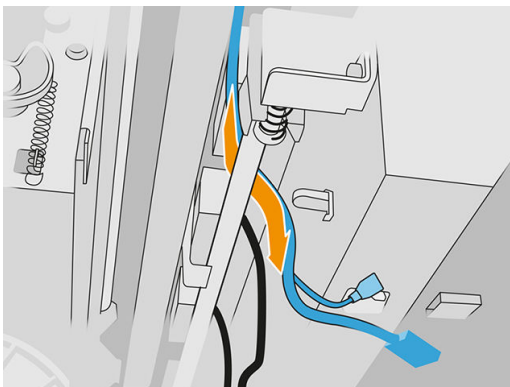

⚠ CAUTION: Be careful to place the new drop detector on the right side of the belt.

9. Route the cable through its holder.



10. Connect the new drop-detector cable to its connectors.

Finish the replacement

1. Close the top cover.
2. Close the printhead cleaning roll door and agent door.
3. Ensure that all windows, covers, and doors are closed and remain in their original positions.
4. Turn on the printer.
5. At the front panel, tap , then **System tools** > **Printer reset counter** > **Drop detector replacement**.
6. Tap , then **System tools** > **Calibrations** > **Drop detector calibration**.
7. Tap , then **System tools** > **Drop detector utilities** > **Drop detector test**.

Replace the recoating roller and recoating plates

Prepare for replacement

1. Ensure that the printer is not printing.
2. If a job has just been printed, wait about 20 minutes for the printer to cool down.
3. You are recommended to wear gloves.
4. Ensure that all windows, covers, and doors are closed and remain in their original positions.
5. Open the top cover.

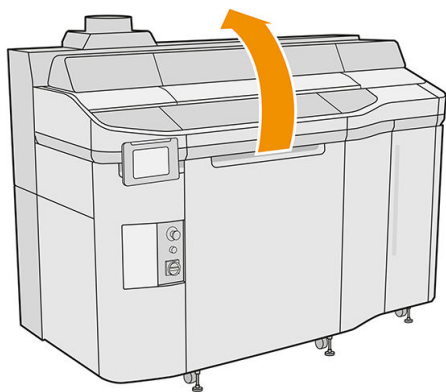

6. Remove the build unit from the printer, if it is present.
7. Move the recoating unit manually to the front, slowly and carefully.

Replace the recoating roller and recoating plates

1. Locate the recoating unit and use a flat screwdriver to remove four T15 screws.

 **CAUTION:** Be careful not to drop the screws.

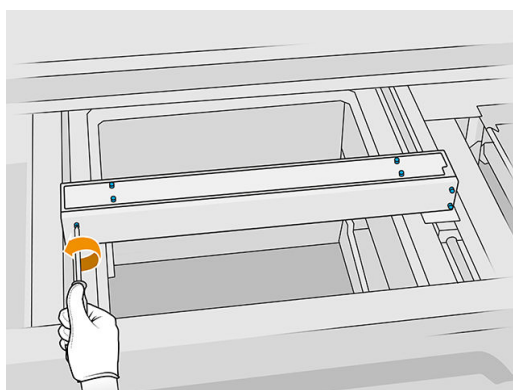

2. Remove the front lid.

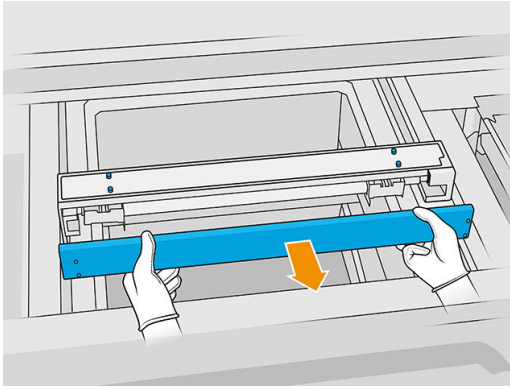

3. Slide the top sheet to one side until you can see the holes; do not remove it completely.

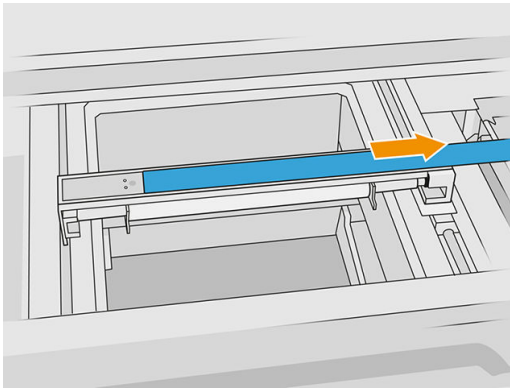

4. Remove two T10 screws from the reflecting plate.

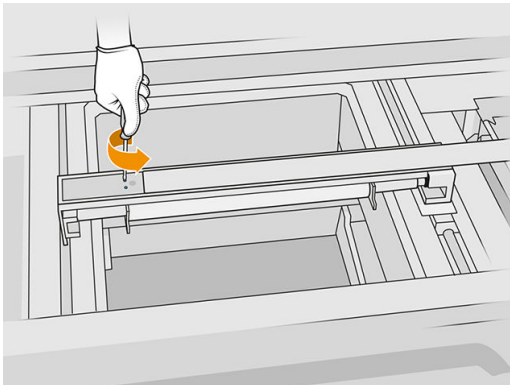

5. Repeat steps 3 and 4 on the other side.

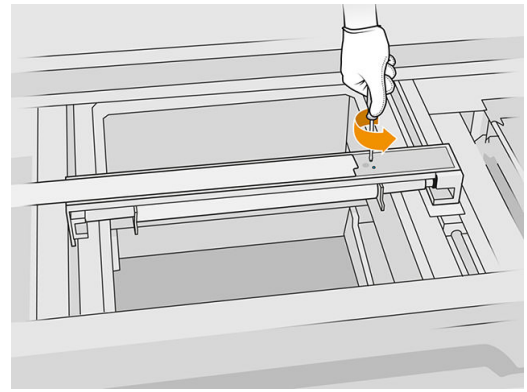
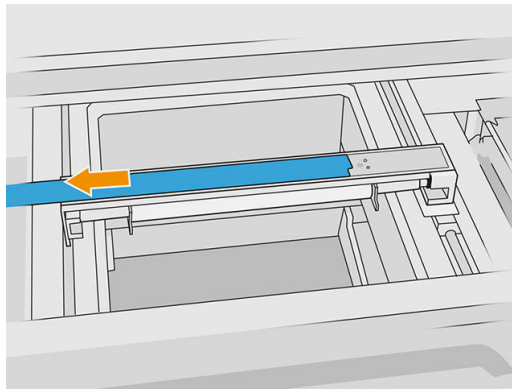

6. Remove the roller by pulling it towards you, and place it gently on a table or flat surface.

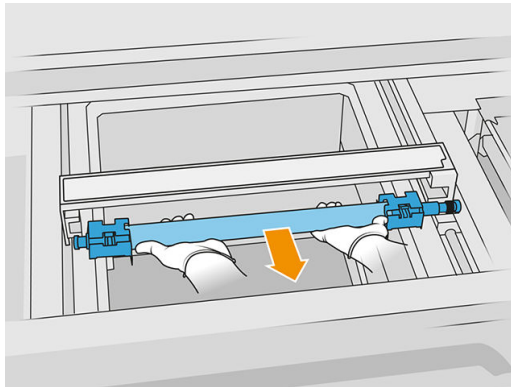

7. Insert the new recoating plates.
8. Carefully insert the new recoating roller by placing it and pushing it to the end.

 **NOTE:** The gears should be on the right when placing the roller.

9. Align the plates with the line as shown below.

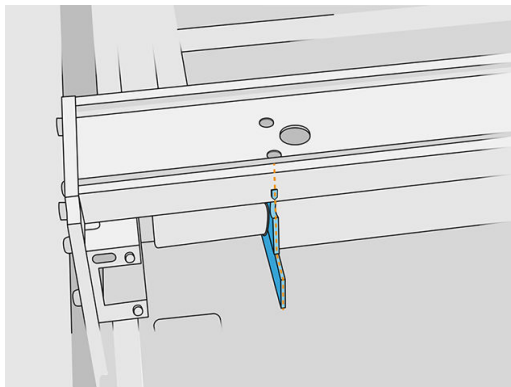

10. Secure the recoating roller with the top four screws.

 **TIP:** Hold the plate up while tightening the top screws.

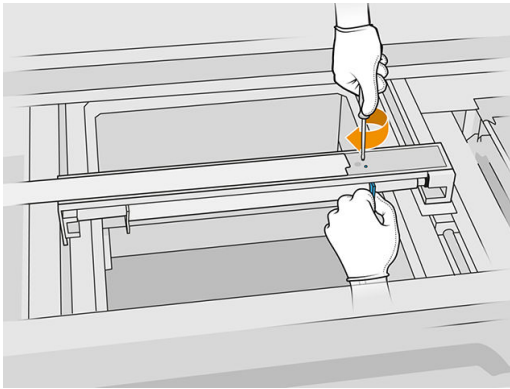

11. Put back the front lid of the recoating unit, but do not insert the screws yet.
12. Slightly rotate the recoating unit in both directions with your hand, ensuring that the roller gears are correctly engaged.

 **CAUTION:** Some parts may be damaged if the gears are not correctly engaged when the lid is closed.

13. Attach the lid with the four T15 screws.

Finish the replacement

1. Close the top cover.
2. Ensure that all windows, covers, and doors are closed and remain in their original positions.

Replace the bottom glass of the heating lamps

Prepare for replacement

1. Ensure that the printer is not printing.
2. If a job has just been printed, wait about 20 minutes for the printer to cool down.
3. You are recommended to wear gloves.
4. Ensure that all windows, covers, and doors are closed and remain in their original positions.

Remove the bottom glass of the heating lamps

- ▲ See [Remove the bottom glass of the heating lamps on page 155](#).

Finish the replacement

1. Close the top cover.
2. Ensure that all windows, covers, and doors are closed and remain in their original positions.

Replace a fusing-lamp external glass

Prepare for replacement

1. Ensure that you have the fusing lamp glass kit.
2. Ensure that the printer is not printing.

3. If a job has just been printed, wait about 20 minutes for the printer to cool down.
4. You are recommended to wear gloves and mask.
5. Ensure that all windows, covers, and doors are closed and remain in their original positions.
6. Turn off the printer.



Risk of burns



Crush hazard



Risk of trapped fingers



Hazardous moving part



Light radiation hazard



Electric shock hazard

For more safety information, see [Safety precautions on page 5](#)

Remove the fusing-lamp module

- ▲ See [Remove the fusing-lamp module on page 151](#).

Replace the fusing-lamp external glass

1. Turn the assembly upside down and unscrew the four screws of the exterior glass frame.
2. Carefully remove the frame of the exterior glass.

⚠ CAUTION: When you remove the frame, the glass may stick to it. Take care that the glass does not fall out of the frame as you pick it up.

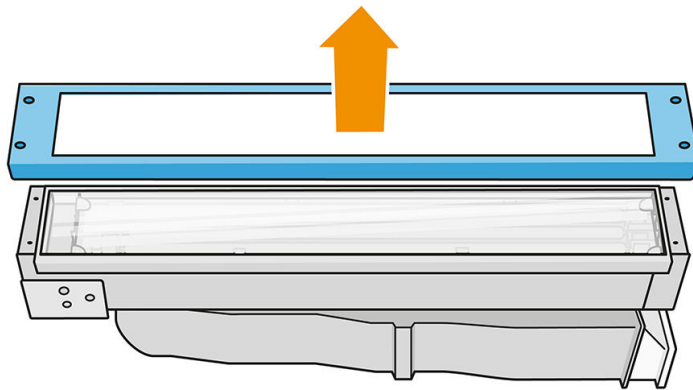

3. Remove the exterior glass and dispose of it according to local regulations.

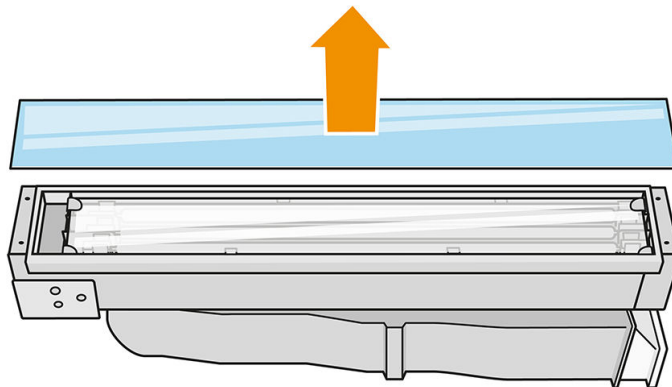

4. Insert the new glass into the frame.
5. Rescrew the exterior glass frame with glass into the module.

Reassemble the fusing-lamp module

- ▲ See [Reassemble the fusing-lamp module on page 154](#).

Finish the replacement

1. Close the top cover.
2. Ensure that all windows, covers, and doors are closed and remain in their original positions.
3. Turn on the printer.

Replace a fusing-lamp internal glass

Prepare for replacement

1. Ensure that you have the fusing lamp glass kit.
2. Ensure that the printer is not printing.
3. If a job has just been printed, wait about 20 minutes for the printer to cool down.
4. You are recommended to wear gloves and mask.
5. Ensure that all windows, covers, and doors are closed and remain in their original positions.
6. Turn off the printer.



Risk of burns



Crush hazard



Risk of trapped fingers



Hazardous moving part



Light radiation hazard



Electric shock hazard

For more safety information, see [Safety precautions on page 5](#)

Remove the fusing-lamp module

- ▲ See [Remove the fusing-lamp module on page 151](#).

Safety precautions for the fusing-lamp emitter

- Disregard of the safety precautions or improper operation of the infrared emitter can lead to injuries and material damage.
- The IR heating device should be operated only by specialists or trained personnel.
The operator of the system should compile specific instructions for personnel training.
- The safety and functional reliability of the IR heating device are guaranteed only if you are using original accessories and spare parts from HP.
- After an emitter break, a dangerous voltage may be exposed to contact by the heating spiral.
- The reflector side should not be cleaned.

Transport and handling of the fusing-lamp emitter

- Transport the IR emitter, in the packaging provided, to the place of installation.

⚠ CAUTION: If the IR emitter must be transported without its packaging, wear linen gloves. Fingerprints on the quartz tube will cause devitrification, which leads to radiation losses and mechanical failure.

- Always carry the emitter with both hands. Carry it so that the cross-section faces up, to avoid bending and breaking.
- Grip the emitter only by the ceramic edges, and not by the connection cable or pinches. Do not touch the glass unless you are wearing gloves.
- Avoid any pressure on the flat base.

When installing IR emitters

- HP recommends that you wear protective goggles when installing or replacing emitters, to protect yourself from broken glass that you may come into contact with.
- The safety and functional reliability of the IR heating device are guaranteed only when using original accessories and spare parts from HP.
- After an emitter break, a dangerous voltage may be exposed to contact by the heating spiral.
- The reflector side should not be cleaned.

After installation, the bottom glasses of the IR emitter must be cleaned of any soiling or perspiration. See [Clean the fusing-lamp glasses on page 150](#).

Replace the fusing lamp

1. Turn the assembly upside down and unscrew the four screws of the exterior glass frame.
2. Carefully remove the frame of the exterior glass.

⚠ CAUTION: When you remove the frame, the glass may stick to it. Take care that the glass does not fall out of the frame as you pick it up.

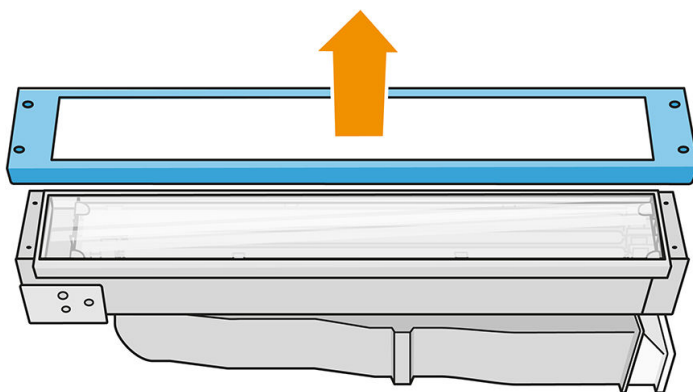

3. Remove the exterior glass.

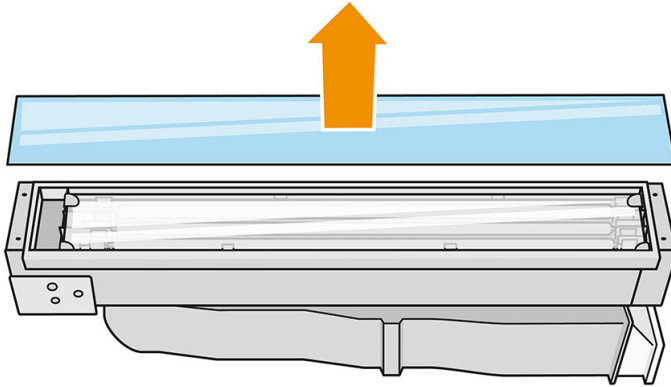

4. Push the metallic clip and remove the internal glass.
5. Remove the lamp, by pulling it upwards.

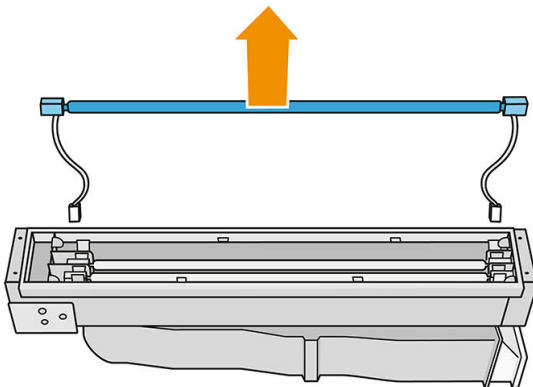

6. Insert the new internal glass into the two rear brackets, and push down the metallic clip to insert the other side.
7. Add the frame with the bottom glass, securing it with four screws.

Reassemble the fusing-lamp module

- ▲ See [Reassemble the fusing-lamp module on page 154](#).

Finish the replacement

1. Clean the fusing-lamp glasses. See [Clean the fusing-lamp glasses on page 150](#).
2. Close the top cover.
3. Ensure that all windows, covers, and doors are closed and remain in their original positions.
4. Turn on the printer.

Replace a heating lamp

At the printer's front panel, tap , then **Heating lamps** to see the status of each lamp:

- **Missing:** The lamp is missing.
- **Replace:** The lamp has been identified as faulty. It should be replaced by a functional lamp.

- **Wrong:** The lamp type is not suitable for this printer.
- **Not in warranty:** The lamp is no longer covered by warranty.

Prepare for replacement

1. Ensure that you have the heating lamps kit, which is included in the printer initial maintenance kit, but can also be purchased separately.
2. Ensure that the printer is not printing.
3. If a job has just been printed, wait about 20 minutes for the printer to cool down.
4. You are recommended to wear goggles and cotton gloves.
5. If present, remove the build unit.
6. At the printer's front panel, tap , then **Heating lamps** to see the status of each lamp. Any lamp identified as faulty should be replaced by a functional lamp: tap **Replace**. The lamps are numbered; remember the numbers of any lamps to be replaced.
7. Ensure that all windows, covers, and doors are closed and remain in their original positions.
8. Turn off the printer.



Risk of burns



Crush hazard



Risk of trapped fingers



Hazardous moving part



Light radiation hazard



Electric shock hazard

For more safety information, see [Safety precautions on page 5](#)

Remove a heating lamp

1. Open the top cover.

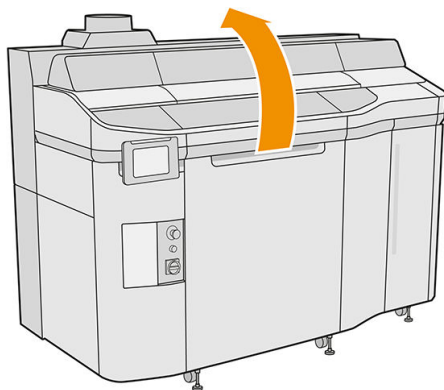

2. Unscrew four captive screws to remove the heating-lamp bottom glass.

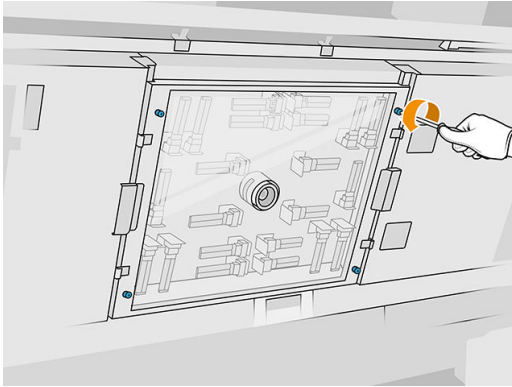

3. Pull the bottom glass out of the top cover and place it gently on a table.

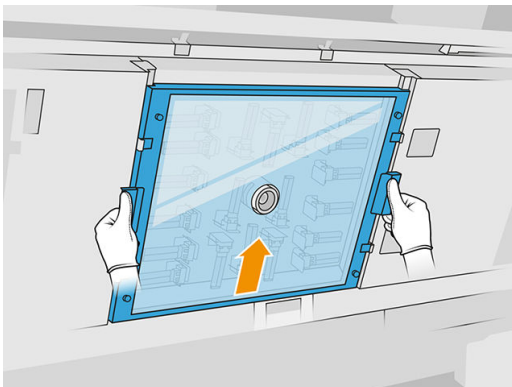

4. Identify which lamp you intend to replace.

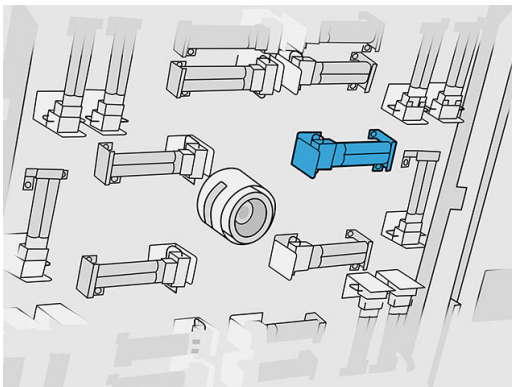

5. Remove the two screws.

- Remove the old lamp by sliding it out to disconnect it from its connector, then dispose of it according to local regulations.

⚠ CAUTION: It is important not to touch the lamps with your fingers. Always wear cotton gloves to handle the lamps.

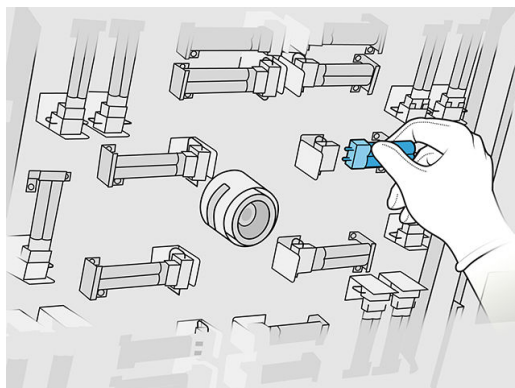

Safety precautions for the heating-lamp emitter

- Disregard of the safety precautions or improper operation of the infrared emitter can lead to injuries and material damage.
- The IR heating device should be operated only by specialists or trained personnel.
The operator of the system should compile specific instructions for personnel training.
- The safety and functional reliability of the IR heating device are guaranteed only if you are using original accessories and spare parts from HP.
- After an emitter break, a dangerous voltage may be exposed to contact by the heating spiral.
- The reflector side should not be cleaned.

Transport and handling of the heating-lamp emitter

- Transport the IR emitter, in the packaging provided, to the place of installation.
-
- ⚠ CAUTION:** If the IR emitter must be transported without its packaging, wear linen gloves. Fingerprints on the quartz tube will cause devitrification, which leads to radiation losses and mechanical failure.
-
- Always carry the emitter with great care, avoiding any impact or shaking. Carry it so that the cross-section faces up, to avoid bending and breaking.
 - Grip the emitter only by the sides of the ceramic connector.
 - Avoid any pressure on the flat base.

When installing IR emitters

- HP recommends that you wear protective goggles when installing or replacing emitters, to protect yourself from broken glass that you may come into contact with.
- The safety and functional reliability of the IR heating device are guaranteed only when using original accessories and spare parts from HP.
- After an emitter break, a dangerous voltage may be exposed to contact by the heating spiral.
- The reflector side should not be cleaned.

Insert a new heating lamp

1. Insert the new heating lamp in the correct position.
2. Put back and tighten the two screws.
3. Put the bottom glass back in place and tighten the four captive screws.
4. Close the top cover.

Finish the replacement

1. Ensure that all windows, covers, and doors are closed and remain in their original positions.
2. At the front panel, tap , then **System tools > Replace parts > Heating lamps replacement**.
3. Next time you switch on the printer, you can check the heating lamp status in the front panel's Supplies app.

Replace an intermediate tank

Prepare for replacement

1. Ensure that the printer is not printing.
2. If a job has just been printed, wait about 20 minutes for the printer to cool down.
3. You are recommended to wear gloves.
4. Ensure that all windows, covers, and doors are closed and remain in their original positions.

Replace an intermediate tank

1. At the front panel, tap , then **System tools > Printer reset counter > Intermediate tank replacement**.
2. Remove two screws from the side cover, then remove the cover.

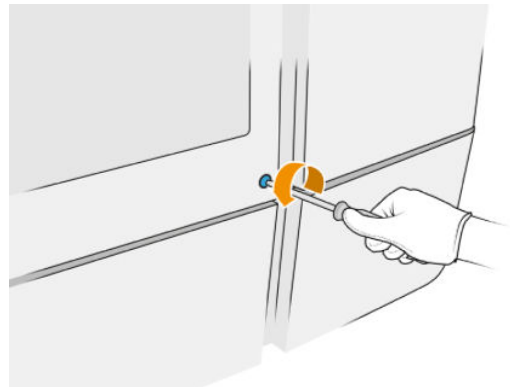
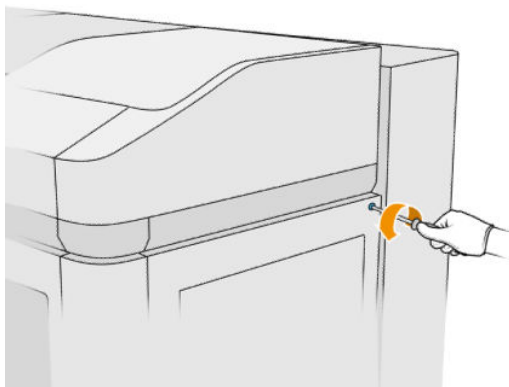

3. Follow strictly the instructions on the front panel. First you will need to remove the F1 or D1 tank and replace it by a new one. After a while, the front panel will tell you to do the same with the F2 or D2 tank. If necessary, repeat the process with the other pair.

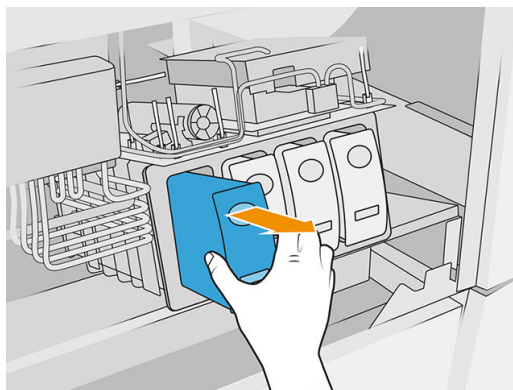

 **NOTE:** Intermediate tanks must be changed in pairs (F1+F2 and D1+D2).

4. Identify the intermediate tanks you have just installed by attaching the appropriate stickers, which are provided.
5. Put back the side cover and the screws.
6. At the front panel, confirm that tanks have been replaced, so that the refilling process can start. This may take some time.

Replace the cleaning-roll collector

Prepare for replacement

1. Ensure that you have the printer user maintenance kit.
2. Ensure that the printer is not printing.
3. If a job has just been printed, wait about 20 minutes for the printer to cool down.
4. You are recommended to wear gloves and goggles.
5. Open the agent door and the external cleaning-roll door.

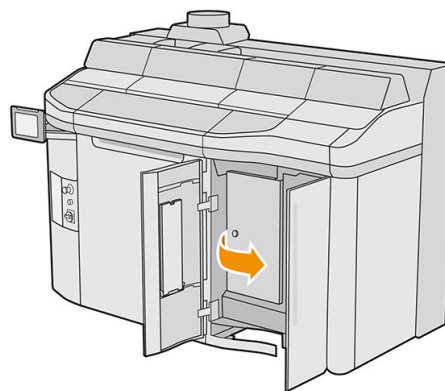
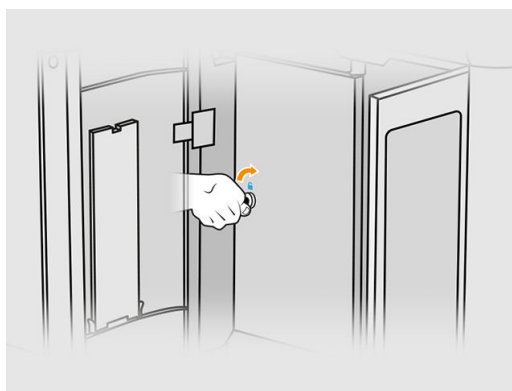

Replace the cleaning-roll collector

1. Locate the cleaning-roll collector, underneath the printhead cleaning roll.

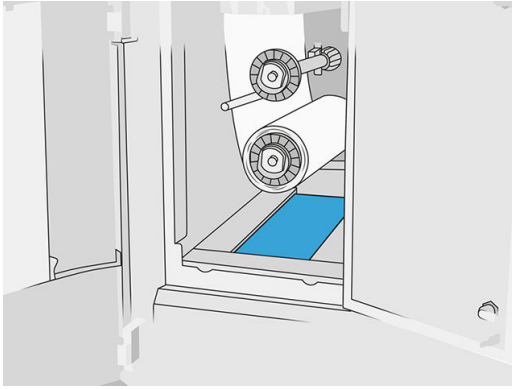

2. Pull out the old collector (foam).

 **TIP:** Remember to wear gloves.

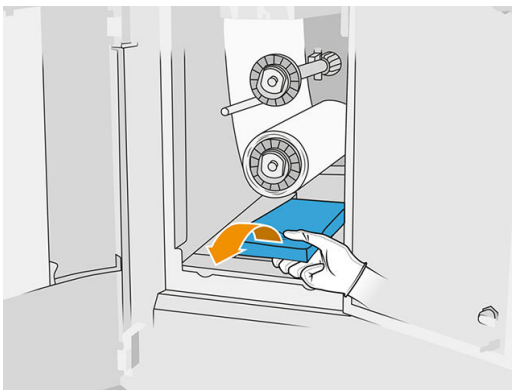

3. Slide in the new collector.

 **CAUTION:** Proper maintenance and genuine HP consumables are required to ensure that the printer operates safely as designed. The use of non-HP consumables (supplies, filters, accessories) may present a risk of fire.

Finish the replacement

1. Close the printhead cleaning roll and agent doors.
2. Consult your local authorities to determine how to dispose of the old collector.

Replace the material extraction system

1. Locate the material extraction system doors on both sides of the printer, and choose one to start with.

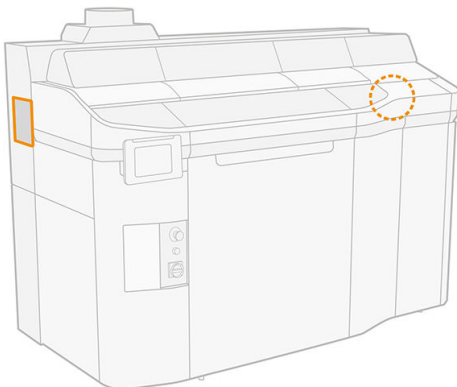

2. Unscrew the two screws.

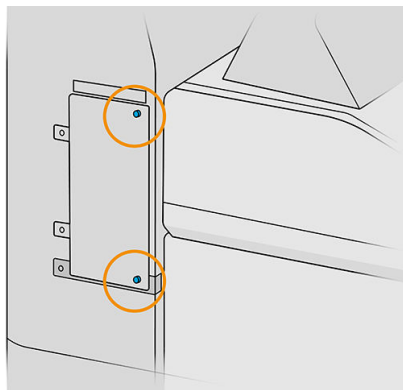

3. Open the door.

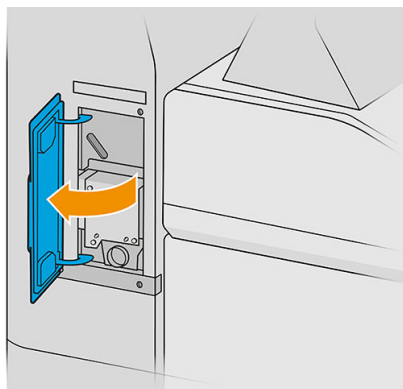

4. Remove four more screws.

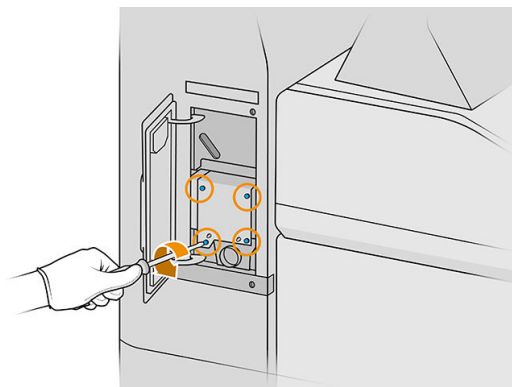

5. Move the material extraction system 5 mm to the front to disengage the positioning pins, and remove it vertically.

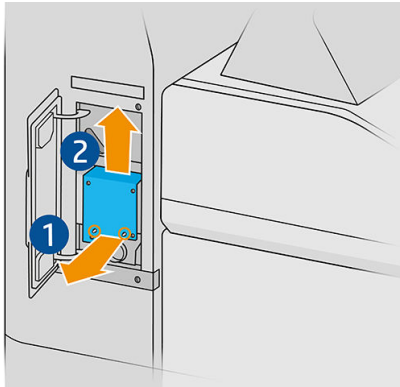

6. Insert the new kit and position it using the pins.
7. Attach it with the four new screws provided with the kit.
8. Close the door.
9. Put back and tighten the two screws.
10. Repeat the process with the other door.

Safety maintenance of the printer

Check the functionality of the Residual Current Circuit Breakers (RCCBs)

Following standard RCCB recommendations, it is recommended that the RCCBs are tested on a yearly basis. The procedure is as follows:

1. Turn off the printer from the front panel, not using the service switch.
2. Test that the RCCB works correctly by pressing the test button.
 - If the RCCB does not trip when the test button is pressed, this indicates that it has failed. The RCCB must be replaced for safety reasons; call your service representative to remove and replace the RCCB.
 - If the RCCB trips, this indicates it is working correctly; reset the RCCB to its normal on state.

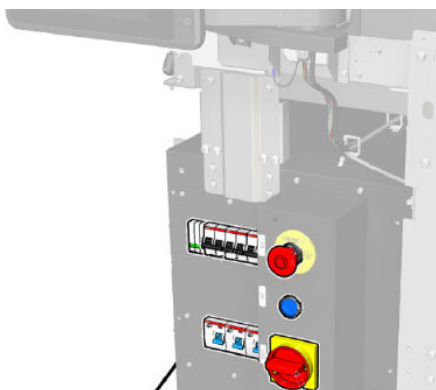

Check that the printer is correctly earthed

Check that the resistance between any metal part of the printer's internal chamber and the building's earth is less than 1 Ω .

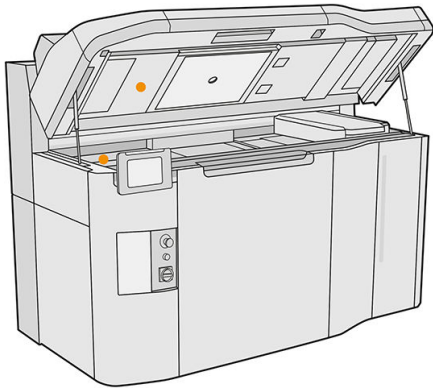

Processing-station maintenance

Summary of maintenance operations

Frequency	Maintenance operation
Before loading	Clean the sieve on page 203
	Clean the loading nozzle sensor on page 204
After unpacking	Clean the working area on page 205
Once a week	Clean the exterior of the processing station on page 207
Once a year	Replace an e-cabinet fan filter on page 212
	Safety maintenance of the processing station on page 213
When requested	Clean the sieve mesh on page 209
	Replace the dust extractor filters on page 214
	Replace the vacuum-pump filter on page 215
	Replace the external tank on page 218

Maintenance operations

Clean the sieve

 **NOTE:** Before some tasks, the front panel may ask you to clean the sieve. At that point, tap **Start** and proceed.

 **IMPORTANT:** If you do not clean the sieve when requested, the loading time may be affected.

Prepare for cleaning

- ▲ Ensure that you have an explosion-protected vacuum cleaner with the following minimum specification:
 - Air flow: 250 m³/h
 - Depression: 19.6 kPa
 - Power: 1800 W

Clean the sieve

1. Open the lid of the vacuum hose connection to the sieve.

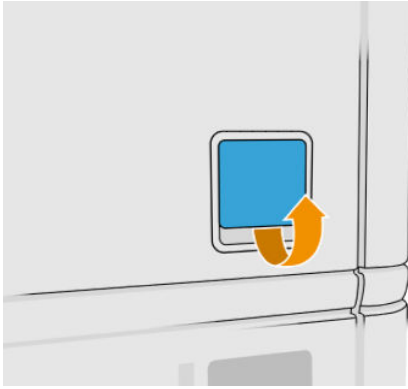

2. Connect an explosion-protected vacuum cleaner, and turn it on.

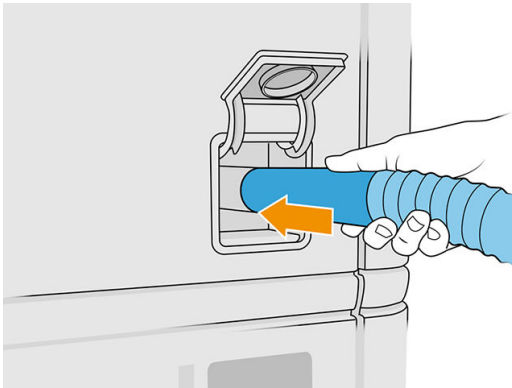

 **NOTE:** If your vacuum hose is different in diameter from the processing station's connector, there are three files for adaptors (50, 60, and 65 mm) that you can find in <http://www.hp.com/go/jetfusion3Dprocessingstation/support>. To use them, first print them out, then remove two screws as indicated below, introduce the printed adaptor, and secure it with the removed screws.

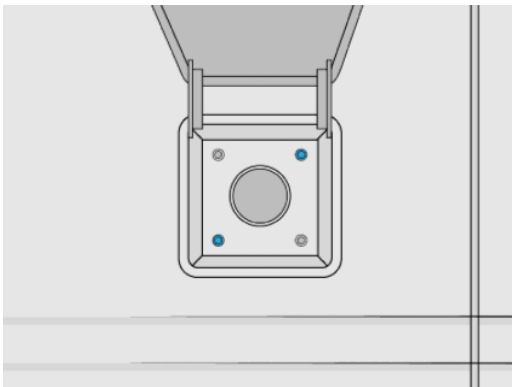

3. When finished, turn off the vacuum cleaner and unplug the hose.

Clean the loading nozzle sensor

Take the loading nozzle and use the hand air blower to blow air on the inner part.

 **IMPORTANT:** Do not touch the sensor.

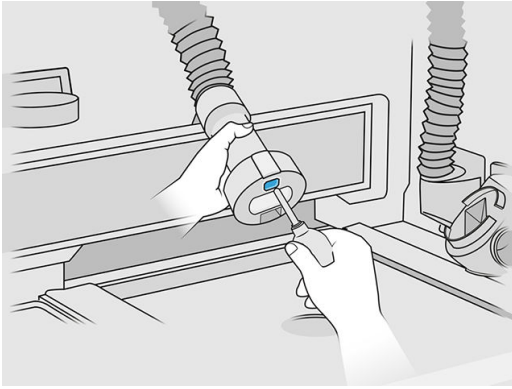

If you can see that the sensor is still dirty, or if you accidentally touched it with your hand, wipe the sensor glass clean by rubbing the surfaces lightly with a lint-free cloth moistened with a general-purpose industrial cleaner, such as Simple Green industrial cleaner. Then immediately wipe it dry with another clean, soft, all-cotton cloth or cotton swab.

Clean the working area

Prepare for cleaning

1. Ensure that you have an explosion-protected vacuum cleaner and an absorbent all-purpose cloth (these things are not provided by HP).
2. Remove the build unit.
3. You are recommended to wear gloves and goggles.

Clean the working area

1. Open the hood.
2. Remove the perforated metal sheet from the working area.
3. Clean the whole working surface, including under the perforated metal sheet, and the edges of the build unit using an explosion-protected vacuum cleaner.

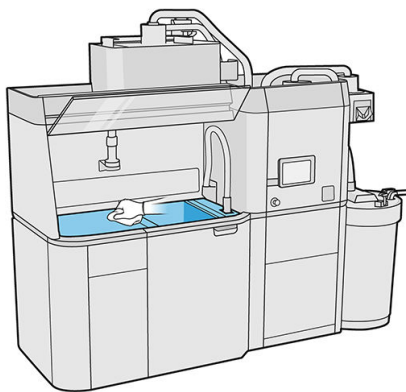

NOTE: Make sure the platform control button area is clean.

4. Clean the front and sides of the processing station using an absorbent all-purpose cloth.

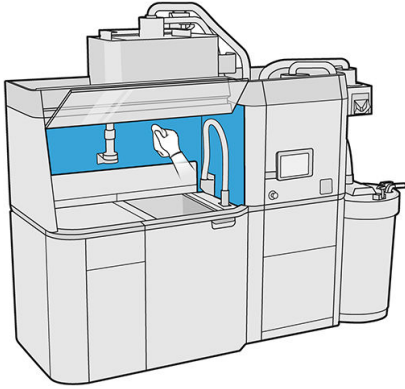

5. Clean the perforated metal sheet, away from the processing station, using an absorbent all-purpose cloth.
6. Clean the inner side of the hood using the same kind of cloth, then close the hood.

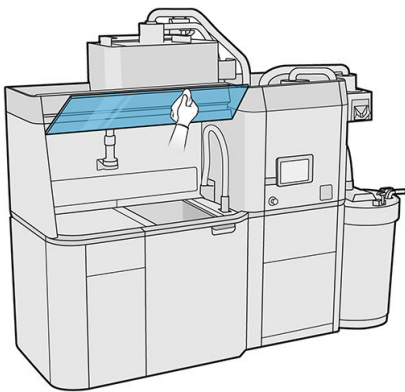

7. Clean the outside of the hood using the same kind of cloth.

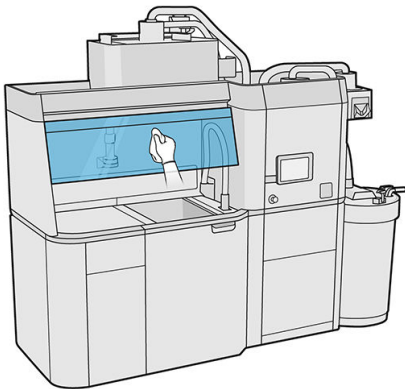

8. Put back the perforated metal sheet.

Clean the build-unit housing

1. Open the build-unit door.

2. Vacuum the build-unit housing and its internal parts.

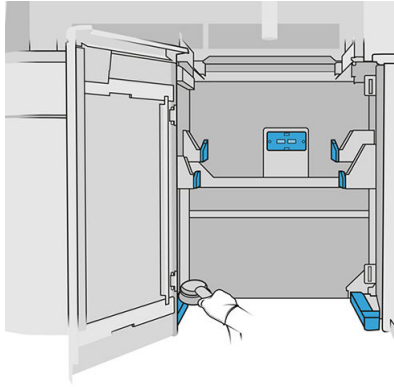

Clean the exterior of the processing station

1. Check the whole processing station for dust, material, or aerosol on covers, doors, and so on.
2. If necessary, clean the processing station further using a vacuum cleaner with a soft brush nozzle.
3. Additionally, you can wipe it with a dry cloth.

Clean the processing station

You may sometimes decide to clean the processing station without purging it, in order to remove the material inside it.

 **NOTE:** After cleaning, some residual material may still remain in the processing station. You can remove more of the material by purging.

 **CAUTION:** It is important to keep the purge tool in the indicated position during the whole process. In case of system error, do not disconnect the hoses; restart the processing station and restart the process, or start an unpacking process to ensure that the material left in the hoses is properly cleaned. If it is not possible to do either of these things, remove the tool from its position, keeping it horizontal to avoid possible material spillages.

Clean the processing station

1. You are recommended to replace the external tank with a new one. Otherwise, the process may be interrupted when the tank is full.
2. At the front panel, tap , then **Material management > Clean the processing station**.
3. Ensure that the external tank is closed, and that the external-tank collector pipe is connected to the cover.
4. Place the sieve connector on the reusable material collector and connect it to the sieve.

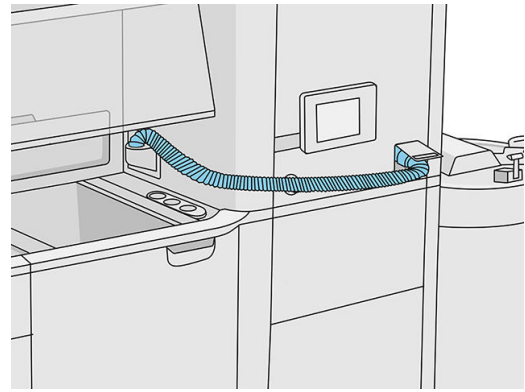
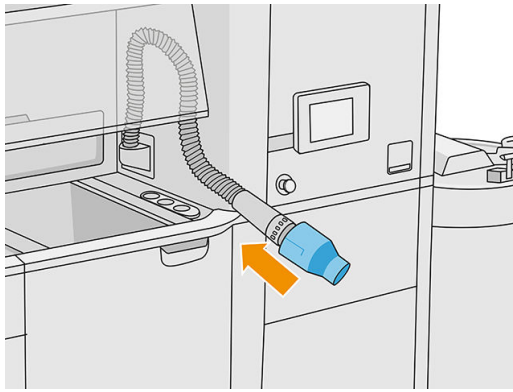

Make sure the reusable material collector is properly connected.

5. Disconnect the material cartridge connectors.

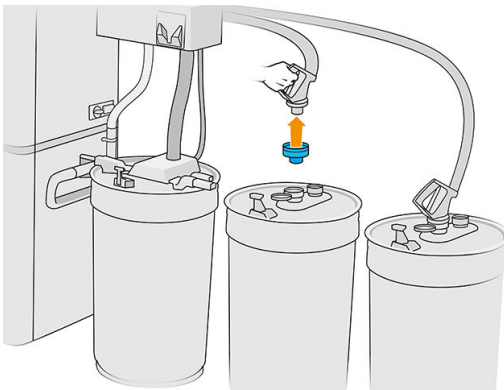

6. Stick each cartridge connector to the outside of the processing station (each connector contains a magnet).
7. Tap **Continue** on the front panel. Remove the external tank collector pipe. The processing station will automatically clean the hose. Wait for the front panel to indicate when it's finished. Put back the hose.
8. Tap **Continue** on the front panel. When the processing station notifies you that it has finished, disconnect the material collector from the sieve and remove the collector.
9. Take the purge tool from the drawer and place it on the side of the working area.

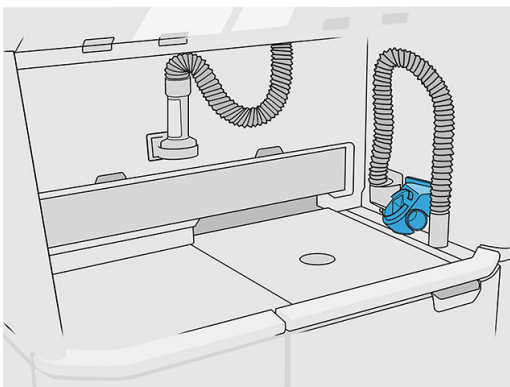

10. Connect the material loading nozzle to the reusable material collector with the purge tool.

⚠ CAUTION: Ensure that the hoses are connected properly. The loading nozzle should be connected to the top and the material collector to the side. If the loading nozzle is correctly connected, the hose should slope gradually downwards; it should not have an 'S' shape.

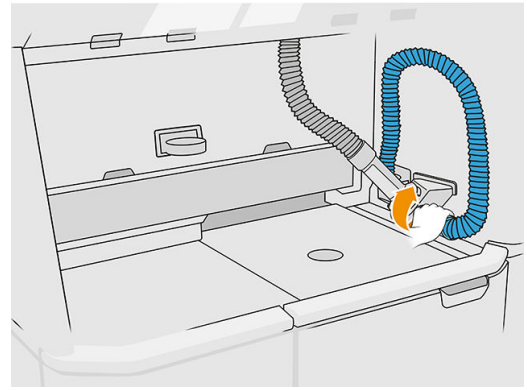
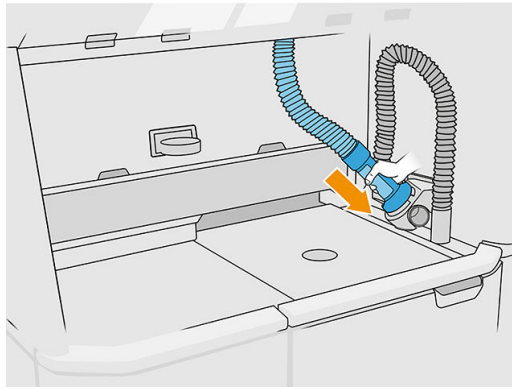

11. Tap **Continue** on the front panel.

 **IMPORTANT:** Do not disconnect the tubes until the cleaning process has finished.

12. Remove the purge tools and place the material collector and material loading nozzle in the parking position. Tap **Continue** on the front panel.
13. Clean the sieve. See [Clean the sieve on page 203](#).

Clean the sieve mesh

1. Turn off the processing station.
2. Open the vacuum-pump filter door.

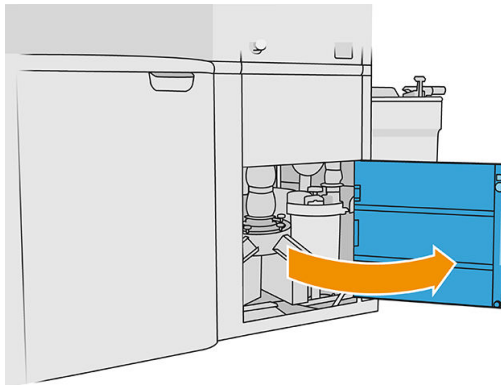

3. Disconnect the Ultrasonic converter cable and hang it from the indicated hook.

 **CAUTION:** To disconnect the Ultrasonic converter cable, grip the plug and pull it out. Do not pull the cable, which could damage the cable, causing a risk of fire and electric shock.

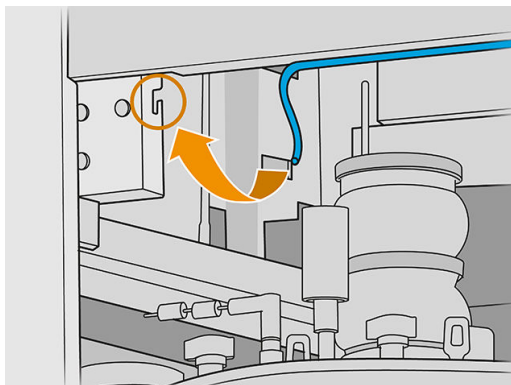

4. Use the provided torque wrench tool to release the Ultrasonic converter, by using a fixed wrench to hold the lower shaft and the torque wrench to unfasten the hexagonal adapter.

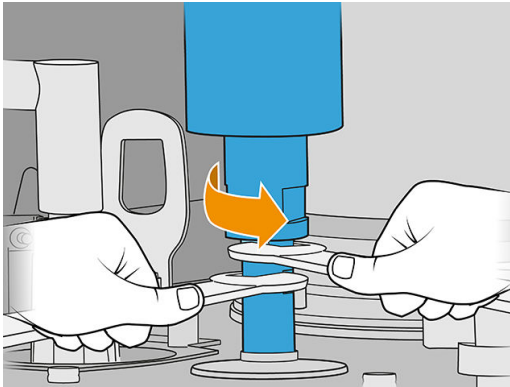

⚠ CAUTION: Not using the fixed wrench to hold the lower shaft could damage the mesh irreversibly.

5. Leave the Ultrasonic converter very carefully where indicated, over the foam.

⚠ CAUTION: Be careful when putting the converter over the foam.

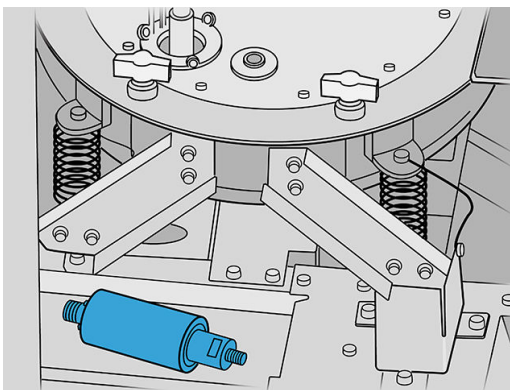

6. Unscrew the six knobs to open the sieve cover and hang it from the two hooks. Vacuum the interior of the sieve with a soft-brush nozzle.

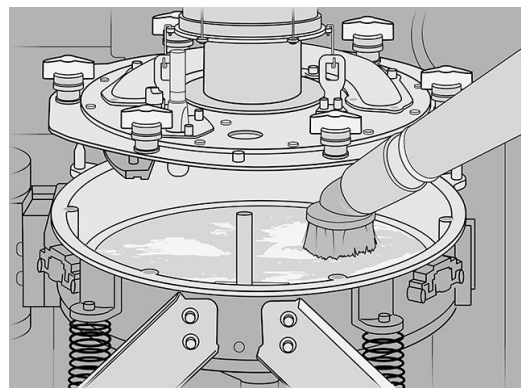
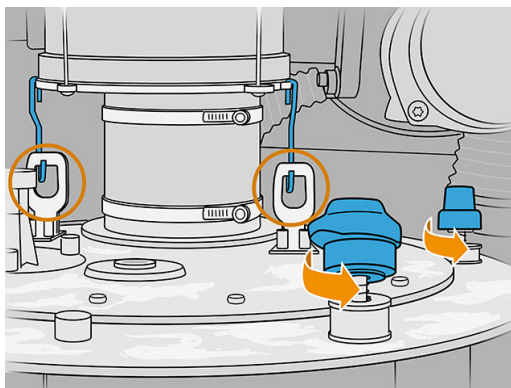

7. Unlock the mesh.

⚠ CAUTION: If you see accumulated material on the mesh, vacuum it using a soft-brush nozzle before unlocking it.

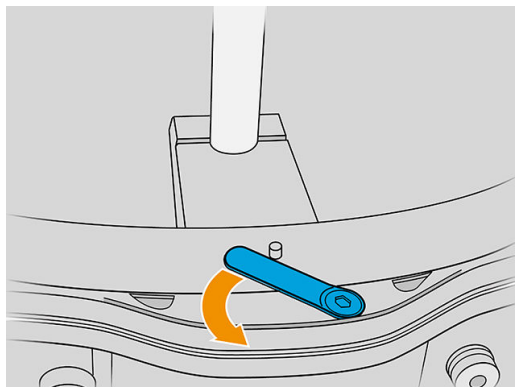

8. Remove the sieve mesh and vacuum it. Clean the cone.
9. Vacuum the screw holes and the screws hanging from the cover.

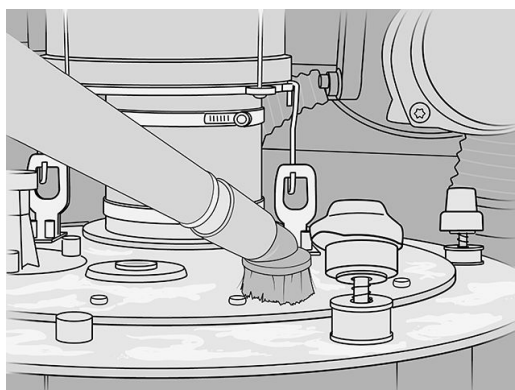

10. Vacuum the sieve perimeter, being careful of the sensors.

⚠ CAUTION: Damage to the sensors can cause a sieve malfunction.

11. Put back the mesh and lock it..

⚠ CAUTION: Make sure the mesh lock is correctly positioned.

12. Tighten each of the six knobs until you hear a click.

⚠ CAUTION: Make sure all knobs are properly tightened, to avoid material spillages outside the sieve.

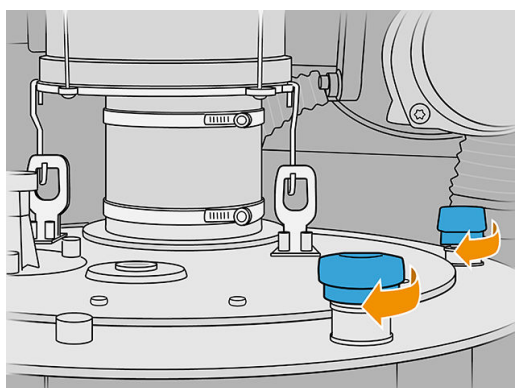

13. Clean the exterior of the sieve area to remove any material that may have fallen there during this procedure.
14. Put back the converter by using a fixed wrench to hold the lower shaft and the provided torque wrench to apply a defined torque of 20 N·m to the hexagonal adapter.

⚠ CAUTION: Not using the fixed wrench to hold the lower shaft could damage the mesh irreversibly.

15. Release the connector from the hook and plug it into the converter. Make sure it is well connected.

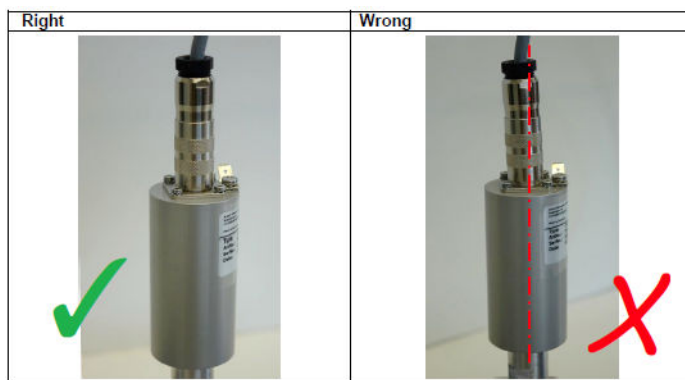

16. Close the door.
17. Turn on the processing station.

Replace the sieve mesh

Follow the same steps as in [Clean the sieve mesh on page 209](#), but replace the mesh with a new one, instead of cleaning the old one.

Replace an e-cabinet fan filter

Prepare for replacement

1. Locate the replacement filters provided in the Processing-station maintenance kit.
2. You are recommended to wear gloves, mask, and safety goggles.
3. Ensure that all windows, covers, and doors are closed and remain in their original positions.
4. Turn off the processing station.

Replace an e-cabinet filter

1. Locate the four e-cabinet filters.

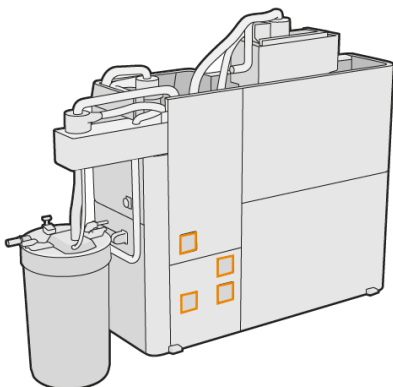

2. Remove the plastic filter cover.



3. Remove and dispose of the old filter according to local regulations, and insert the new one.

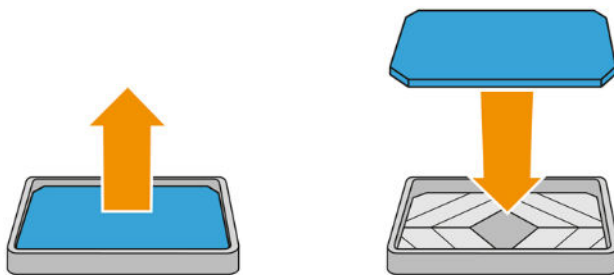

4. Carefully put back the filter cover.

Finish replacement

1. Ensure that all windows, covers, and doors are closed and remain in their original positions.
2. Turn on the processing station.

Safety maintenance of the processing station

Check the functionality of the Residual Current Circuit Breaker (RCCB)

Following standard RCCB recommendations, it is recommended that the RCCB is tested on a yearly basis. The procedure is as follows:

1. Turn off the processing station from the front panel, not using the service switch.
2. Test that the RCCB works correctly by pressing the test button.
 - If the RCCB does not trip when the test button is pressed, this indicates that it has failed. The RCCB must be replaced for safety reasons; call your service representative to remove and replace the RCCB.
 - If the RCCB trips, this indicates it is working correctly; reset the RCCB to its normal on state.

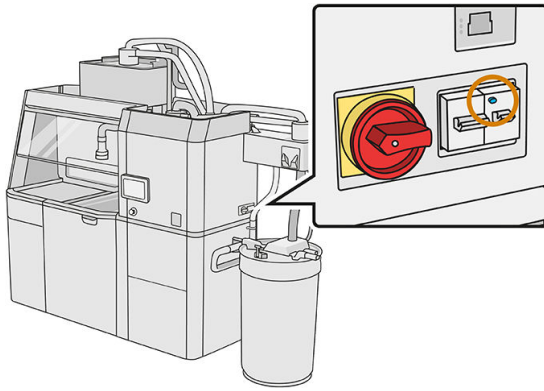

Check that the processing station is correctly earthed

Check that the resistance between any metal part of the processing station's internal chamber and the building's earth is less than 1 Ω .

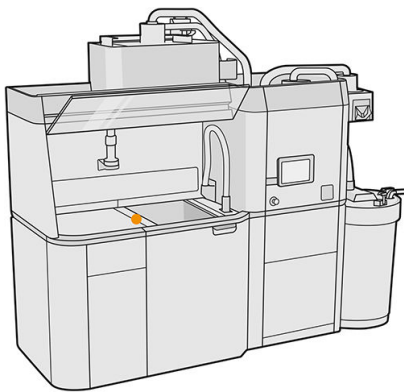

Replace the dust extractor filters

1. Start the replacement from the front panel, when requested.
2. Clean the door with an explosion-protected vacuum cleaner.
3. HP recommends cleaning the filters through the door grid, to avoid splashing the material when extracting the filters.
4. Ensure that the build unit is inserted.
5. Do not touch the filter papers, and always follow the instructions from the manufacturer.
6. Remove the cover locking screws by hand, and open the cover to access the filters.

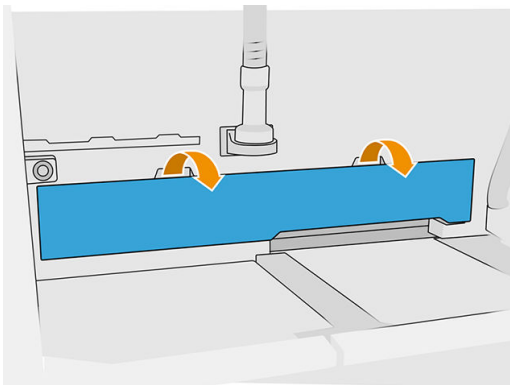

7. Pull the right-hand filter out of its enclosure.

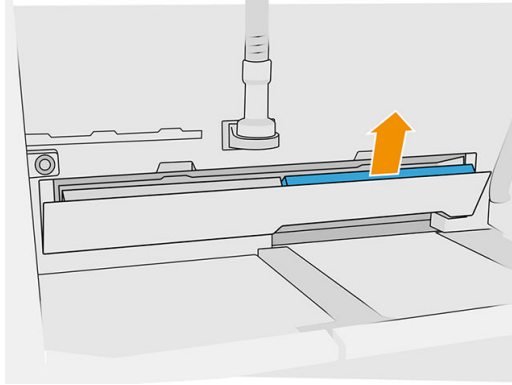

8. Pull the left-hand filter out of its enclosure.

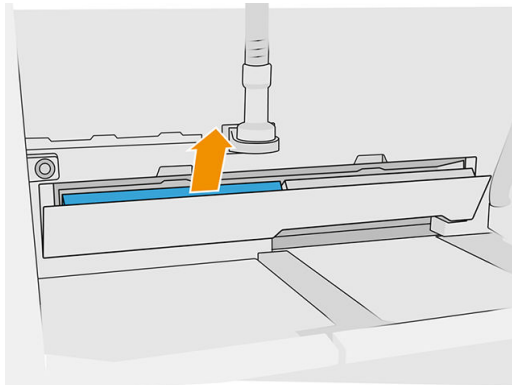

9. Dispose of the old filters according to local regulations.
10. Vacuum the area with an explosion-protected vacuum cleaner.
11. Insert the two new filters. Take care to insert the filter correctly: the arrow on the side of the filter should point towards the interior of the processing station.



12. Close the cover, pushing it back. At the same time, tighten the door locking screws by hand. Make sure they are completely tightened.

Replace the vacuum-pump filter

Prepare for replacement

1. Locate the new vacuum-pump filters, which are provided in the Processing-station maintenance kit.
2. Ensure that the processing station is not in use.
3. You are recommended to wear goggles, gloves, and mask.

Replace the vacuum-pump filter

1. Start the replacement from the front panel, when requested.
2. If material cartridges are placed on the front of the processing station, remove them.
3. Clean the handle parking area and the top surface of the material cartridges with an explosion-protected vacuum cleaner.

 **NOTE:** Material may leak from the handles.

4. Open the cover.

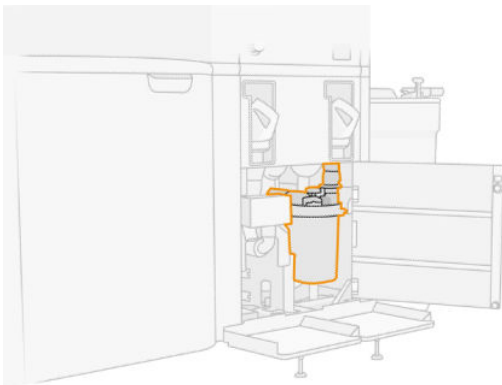

5. Completely unscrew the knob to release the filter.

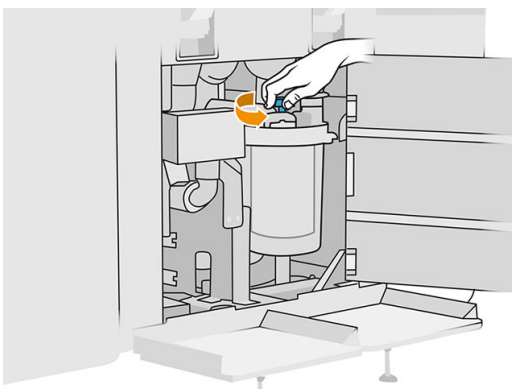

6. Rotate the container clockwise to release it.

 **CAUTION:** Be careful with the sensor when removing the container. Damage to the sensors can cause a sieve malfunction.

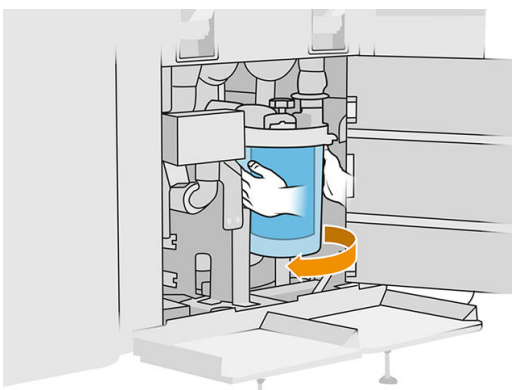

7. Remove the filter and dispose of it according to local regulations.

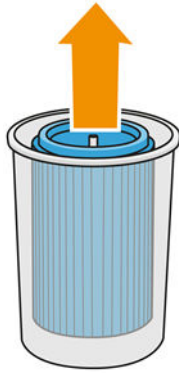

8. Clean the inside of the container with an explosion-protected vacuum cleaner.



9. Insert the new filter between the container and the central tube, with the closed end at the top and the open end at the bottom.

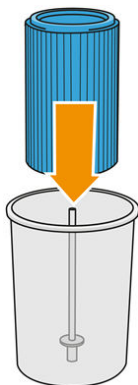

10. Rotate the container anti-clockwise.

⚠ CAUTION: Be careful with the sensor when removing the container. Damage to the sensors can cause a sieve malfunction.

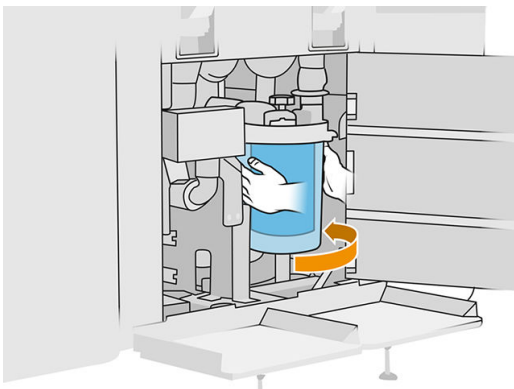

11. **IMPORTANT:** Tighten the knob to lock the container and filter.

Finish the replacement

1. Clean the sieve lid and bottom area cover with an explosion-protected vacuum cleaner.

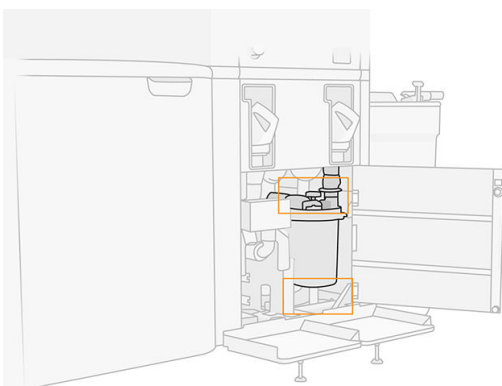

2. Close the cover.
3. Place and connect the material cartridges.

Replace the external tank

1. Start the replacement from the front panel by tapping , then **Other supplies > Replace** (on the external tank card).

2. Open the two latches that lock the lid.

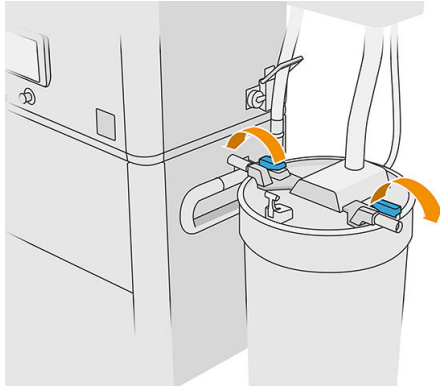

3. Open the lid by pulling it up, and hang it on the structure.

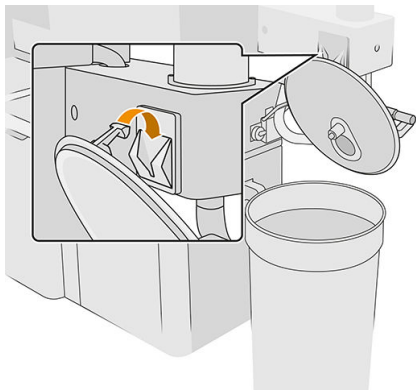

4. Get the storage lid that came with the external tank when purchased and use it to close the tank.

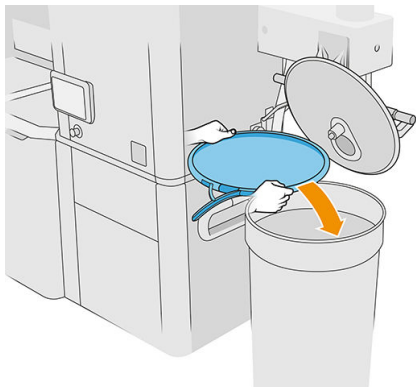

5. Latch the lid.

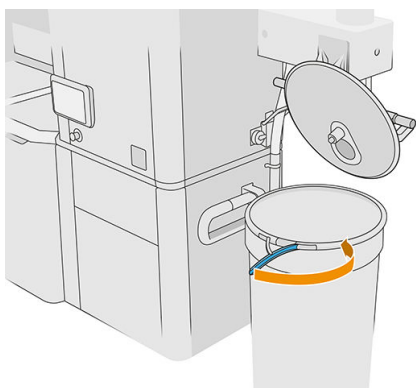

6. Use a lift trolley to remove the tank to a storage area.

 **IMPORTANT:** The tank should be stored in the same environmental conditions as specified for the processing station, otherwise the material may become unusable. The simplest solution is to keep it in the same room as the processing station, well away from sources of heat or cold. Depending on the material, it may be sensitive to temperature, humidity, or other factors.

7. Clean the inner side of the lid using an explosion-protected vacuum cleaner.



8. Use a lift trolley to bring the tank that you intend to use.

 **IMPORTANT:** Use a trolley only to move the external tank. When the processing station is working, the external tank should be on the floor, at the same level as the processing station.

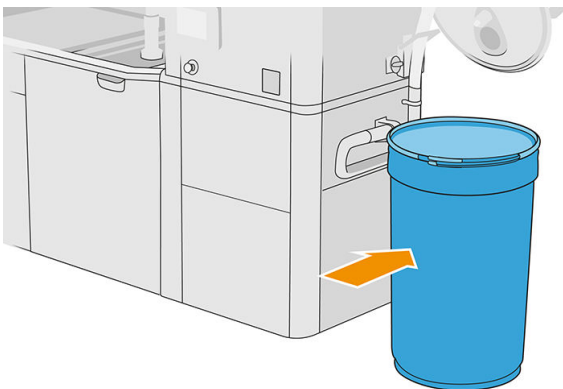

9. Unlatch and remove the storage lid.

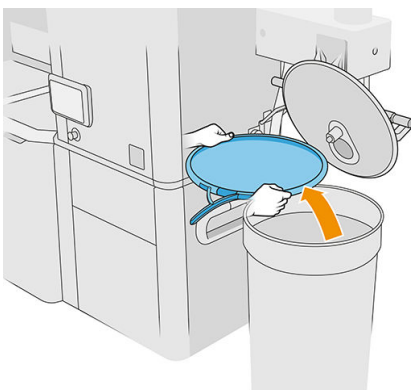

10. Close the lid and lock it with the latches.

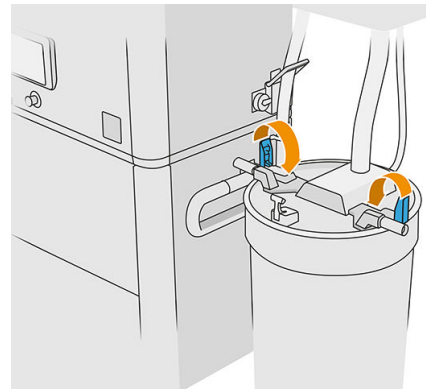
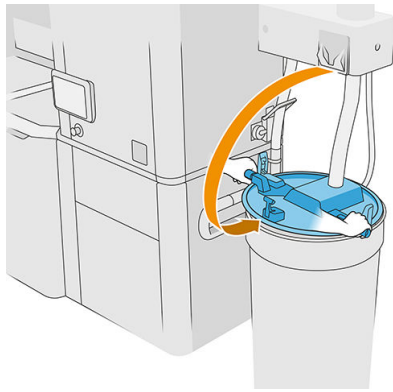

 **NOTE:** Check that the external-tank collector is connected to the storage-tank cover.

11. The front panel displays the status as ready.

 **CAUTION:** Use HP-certified external tanks only. The use of third-party external tanks can cause safety risks, material leakages, and malfunctions in the processing station; and may affect your system warranty.

Build-unit maintenance

Summary of maintenance operations

Frequency	Maintenance operation
Once per build, after unpacking	Clean the surface of the build unit on page 221
Once a week	Clean the exterior of the build unit on page 225
Once a year	Replace the build-unit material-chamber filters on page 226
Before changing the mix ratio	Clean the surface of the build unit on page 221

Maintenance operations

Clean the surface of the build unit

Prepare for cleaning

1. Ensure that you have a lint-free cloth (not provided by HP).
2. Ensure that you have unpacked any build.
3. Ensure that the platform is in the highest position and the build unit is empty.
4. Ensure that the build unit is inside the processing station.
5. You are recommended to wear gloves.

Clean the build unit

1. Vacuum the build-unit printing platform with the reusable material collector.

2. Vacuum the front overflow tray.

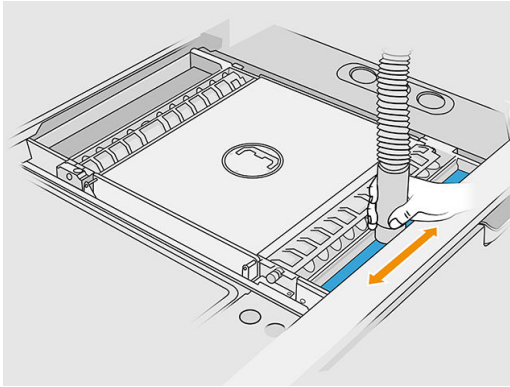

3. Remove the front and rear vane feeders by pressing each feeder against the wall and moving it aside.

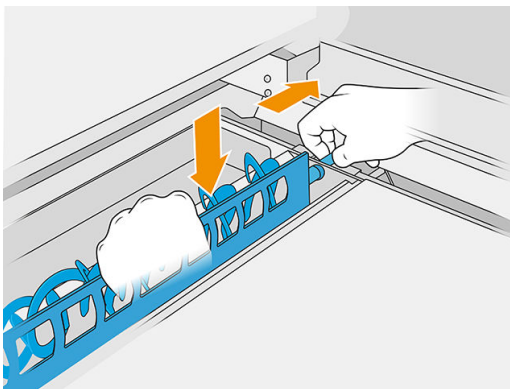
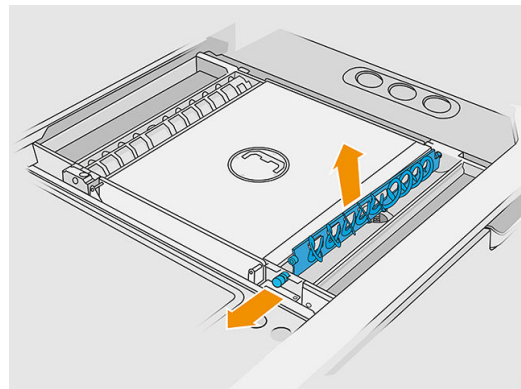
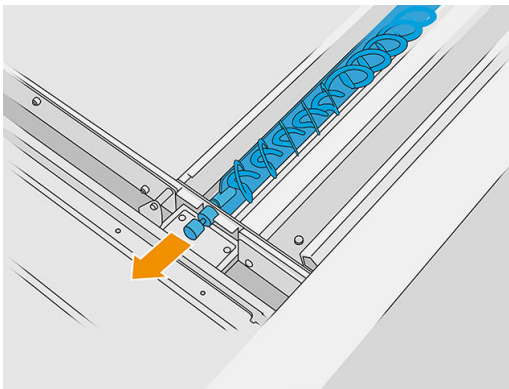

4. Use the reusable material collector to vacuum the vane feeders that you removed.

5. Attach the crevice nozzle to the reusable material collector.

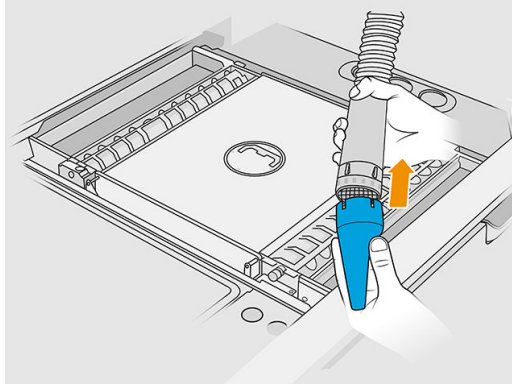

6. Vacuum the front and rear feed trays. Pay special attention to the corners of the trays and underneath the mesh shaker.

 **IMPORTANT:** Do not use the wide nozzle for this operation.

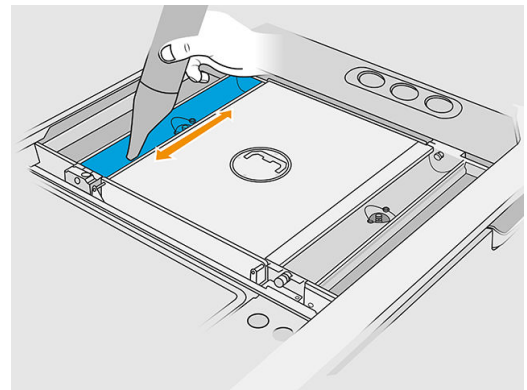
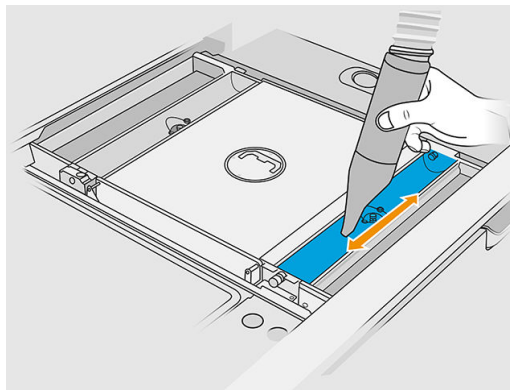

7. Clean the feed tray cavities with a cloth, making sure that no solidified material is left. Try to remove as much material as possible. The result should be at least as clean as shown below.



8. Clean the recoating unit wiper at the rear.

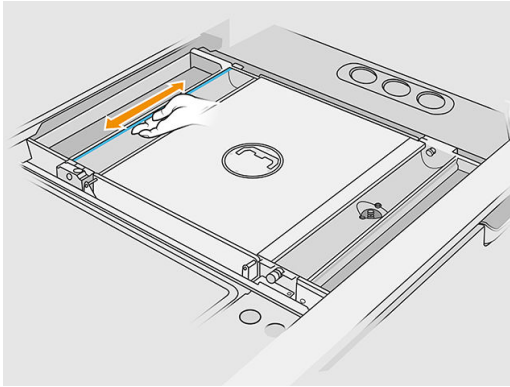

9. Clean the front and rear vane feeders with a cloth. Also use a scourer if necessary to remove all material.

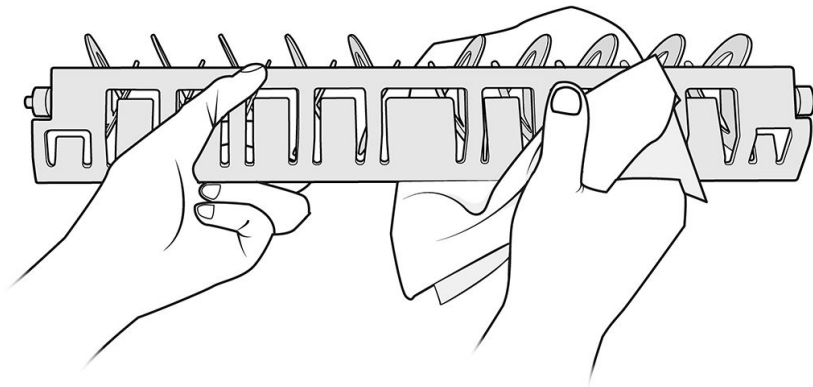

10. Vacuum the feed trays again, making sure there is no material left.

11. Vacuum the overflow trays.

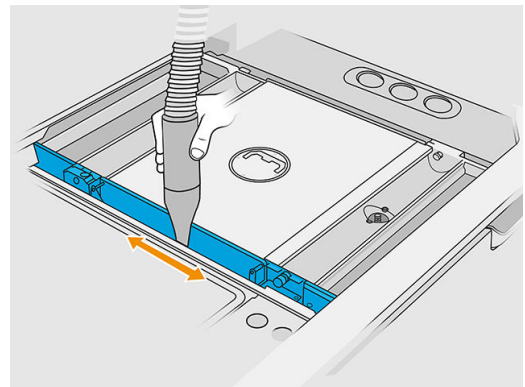
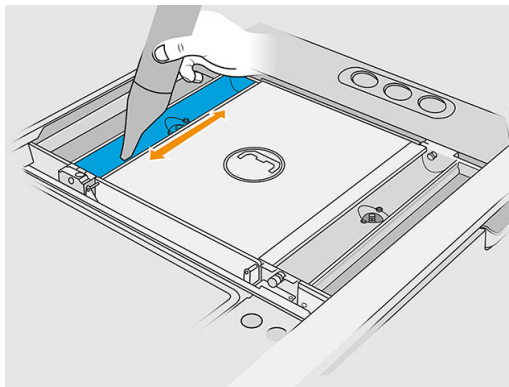

12. Attach the wide nozzle to the reusable material collector.

13. Vacuum the build unit platform.

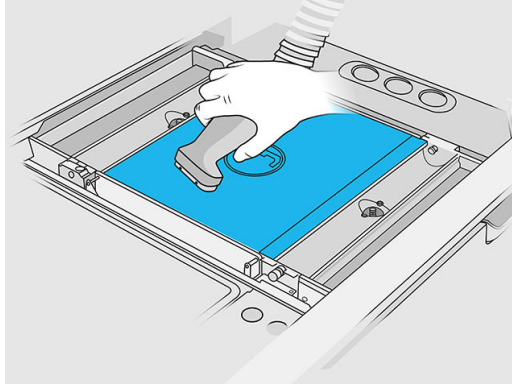

Finish cleaning

1. Put the vane feeders back into their original positions.

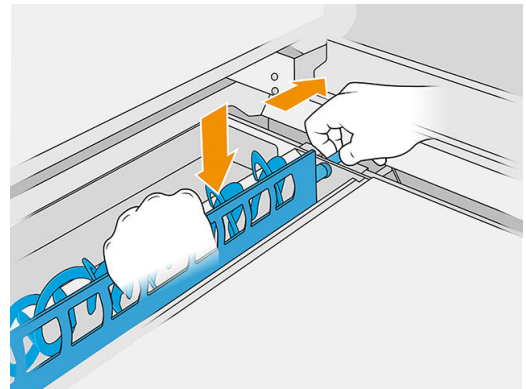
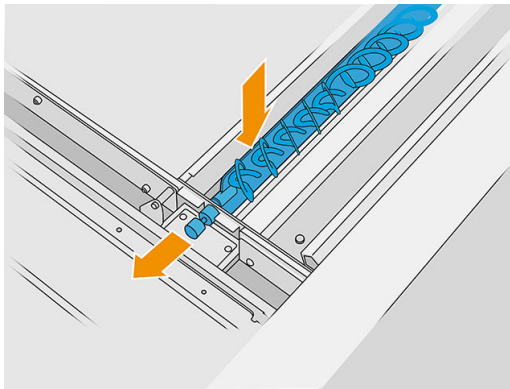

2. Attach the unpacking nozzle to the reusable material collector and leave it in the parking slot.

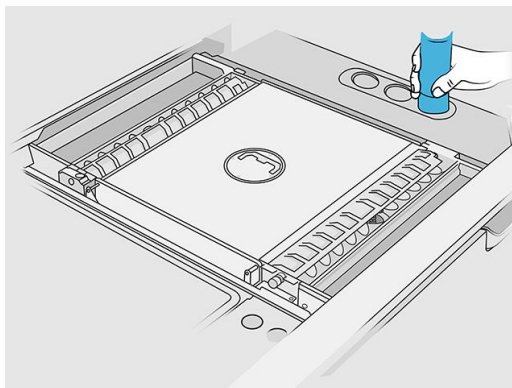

3. The processing station checks that the vane feeders are working correctly.

Clean the exterior of the build unit

Prepare for cleaning

1. Ensure that you have an explosion-protected vacuum cleaner, an absorbent all-purpose cloth, and deionized water (these things are not provided by HP).
2. You are recommended to wear gloves, mask, and goggles.
3. Remove the build unit from the processing station.

Clean the exterior of the build unit

1. Clean all top surfaces with a cloth dampened with deionized water.
2. Clean dust or material from the external surfaces and parts of the build unit: covers, handle, and structure. You can use an explosion-protected vacuum cleaner with a soft brush nozzle.
3. Alternatively, you can wipe it with a dry cloth.

Replace the build-unit material-chamber filters

Prepare for replacement

1. Replacement filters are provided with your printer in the printer yearly maintenance kit. Only one set of filters is needed for this operation.
2. Ensure that the printer is not printing.
3. If a job has just been printed, wait about 20 minutes for the printer to cool down.
4. You are recommended to wear gloves and mask.
5. Ensure that all windows, covers, and doors are closed and remain in their original positions.
6. Remove the build unit from the printer.

Replace the build-unit material-chamber filters

1. Locate the filters at the bottom left and right of the build chamber.

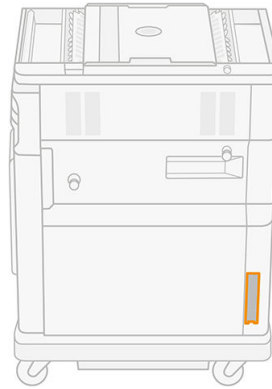
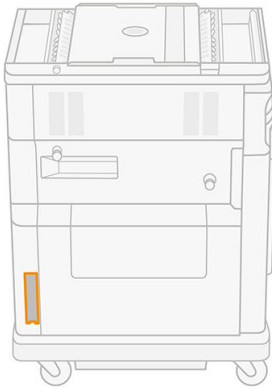

2. Pull off the filter assembly.

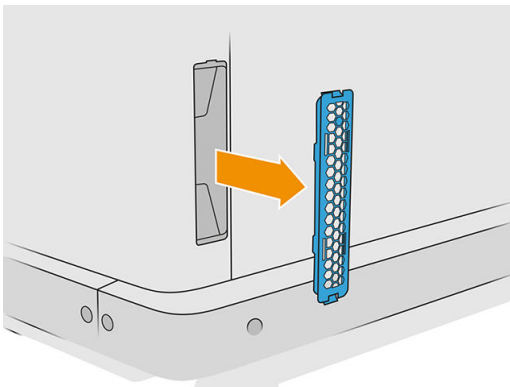

3. Separate the felt of the filter from the grid retainer and the guard.

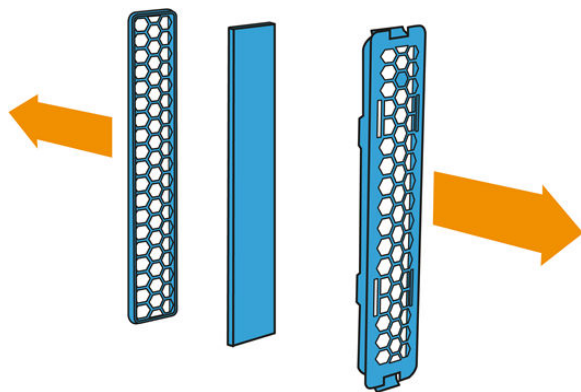

4. Dispose of the old felt according to local regulations, and carefully insert the new felt between the grid retainer and the guard.

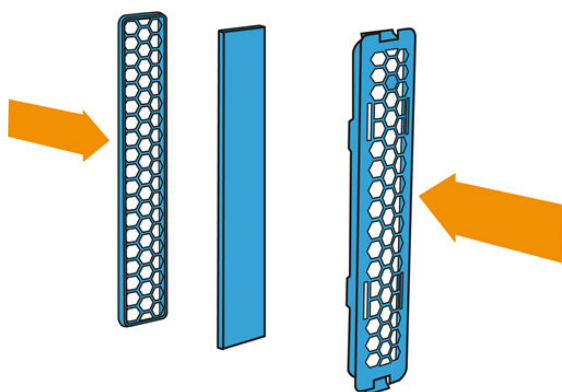

5. Put the fan filter assembly back in place.

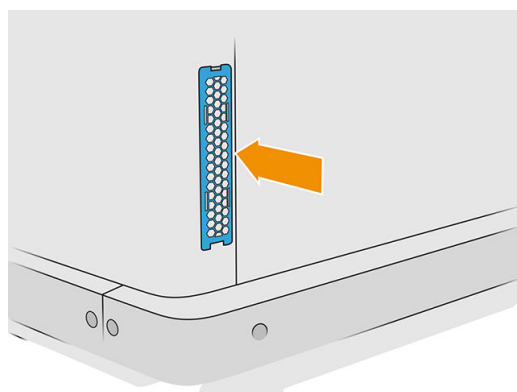

Move or store the product

IMPORTANT: If your HP Jet Fusion 3D Printing Solution needs to be moved to a different location or room, you should contact your reseller for assistance. This product has sensitive components that can be damaged during transportation: special transportation features and tools are needed.

If you need to move the processing station slightly within the same flat room, without steps or using ramps to change level, do it carefully. You may need to do this in order to perform tasks such as cleaning the working area, or small maintenance operations such as filter replacements. In this case, move it on its own wheels only over smooth, flat surfaces, within a room higher than 2.5 m (8 ft 2 in). Do not attempt to go up or down steps, and make sure there is no risk of knocking the station, which could cause serious damage. For any other movement, contact your reseller for assistance.

Do not move the printer for any purpose without service assistance. Additional packing precautions and installation calibrations are required for significant displacements of the equipment.

To store the printer, processing station, and build unit for an extended period of time (longer than a weekend), first clean each device, ensuring that there is no material left inside. See:

- [Clean the print zone, carriage, and housing structure on page 128](#)
- [Clean the working area on page 205](#)
- [Clean the processing station on page 207](#)
- [Empty the material from the build unit on page 97](#)
- [Check and clean the interior of the build unit on page 102](#)

Material extracted must be kept within the storage conditions of the material. The equipment should be stored at a temperature of -25°C to 55°C and humidity of less than 90% (without condensation). Before using it again, allow at least 4 hours for it to acclimatize to operating conditions, and check for condensation before turning it on.

For a shorter period (one weekend), if you want to keep material inside the product, the product operating conditions must be met.

13 Print-quality optimization

- [General advice](#)
- [Printhead health troubleshooting](#)
 - [Align the printheads](#)
 - [Printhead Health Gauge front-panel messages](#)
 - [Nozzle status](#)
 - [Print the printhead status plot](#)
 - [How to interpret the printhead status plot](#)
 - [What to do when the printheads show these defects](#)
- [Recover \(clean\) the printheads](#)
- [Airflow check](#)

General advice

When you have any print-quality problem:

- To achieve the best performance from your system, use only genuine manufacturer's supplies and accessories, whose reliability and performance have been thoroughly tested to give trouble-free performance and best-quality prints.
- Check that your environmental conditions (temperature, humidity) are in the recommended range.
- Check that your material cartridges and printheads have not passed their expiration dates.
- Check that you are using the most appropriate settings for your purposes.

For the latest information, see:

- <http://www.hp.com/go/jetfusion3D5200/support>
- <http://www.hp.com/go/jetfusion3D5210/support>
- <http://www.hp.com/go/jetfusion3D5210pro/support>
- <http://www.hp.com/go/jetfusion3Dprocessingstation/support>

The following procedures may help to solve some print-quality issues, see specific print-quality issues for details if the issue is detected:

- [Align the printheads on page 230](#)
- [Print the printhead status plot on page 240](#)
- [Recover \(clean\) the printheads on page 245](#)
- Tap  then **System tools** > **Calibrations** > **Fusing lamps calibration**

Printhead health troubleshooting

Align the printheads

Printhead alignment is recommended in these situations:

- After replacing or reseating a printhead
- After a printhead crash
- When there are print-quality problems that could be caused by printhead misalignment, such as:
 - Printhead-to-printhead misalignment along the X axis

If a flat plane is printed parallel to the YZ plane and there is a printhead-to-printhead misalignment, there will be a shift of the whole plane along the X axis.

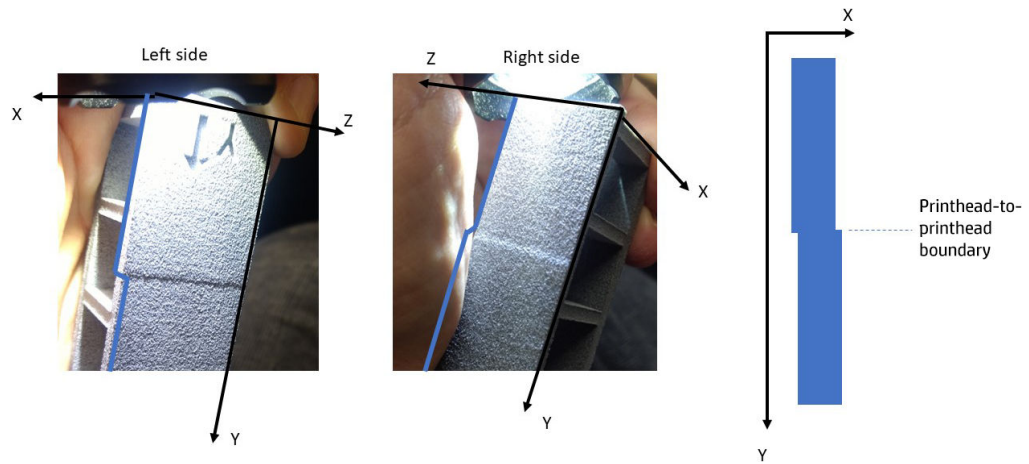

- Bi-directional alignment error

If a flat plane is printed parallel to the YZ plane and there is a bi-directional alignment error, the part may be thinner or thicker than intended.

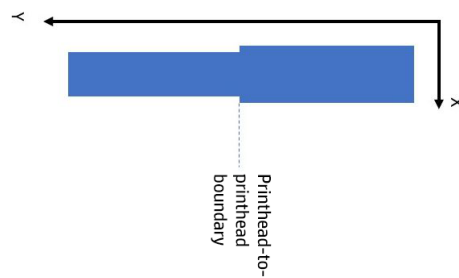

- Printhead-to-printhead misalignment along the Y axis

If there is a printhead-to-printhead misalignment along the Y axis, parts that are printed in the printhead-to-printhead boundary area may be larger or smaller than parts printed by a single printhead.

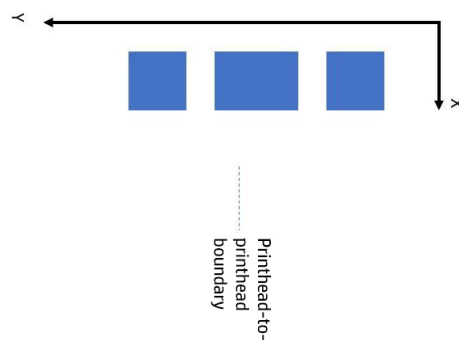

 **NOTE:** If the paper is moved out of the printer by mistake during the alignment process, restart the process.

Manual printhead alignment

1. Go to the front panel and tap , then **Printheads > Align**, then follow the instructions on the front panel.

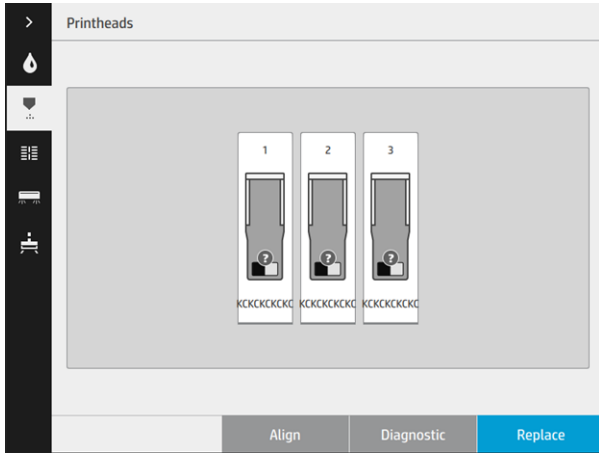

- When you've finished, the pattern is printed. Check the pattern.

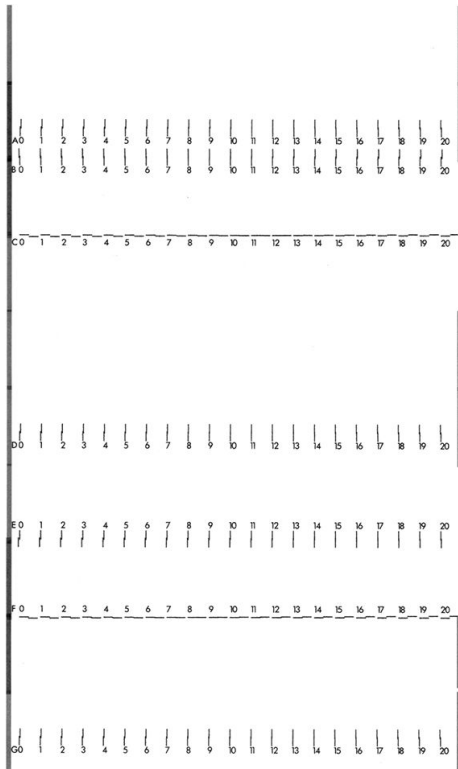

- For every letter, choose the line that is continuous (with no break in the middle), and enter at the front panel the number next to the continuous line. If you see several lines that seem continuous, choose the middle one.

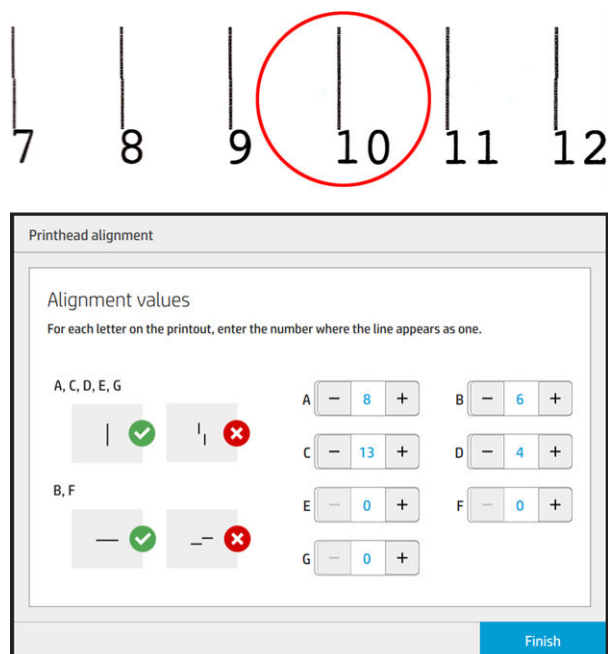

- Check that the alignment has been done correctly by tapping **Diagnostic** in the **Printhead** card. Place the tool covered by paper in position 1 again; and, after printing, check that the triangle is next to the continuous line in all cases. If it is, the alignment is correct.

If there is not a continuous line above the triangle, the pattern should be fine-tuned. To do that, look for the continuous line in the pattern and add its number to the number you used before. For example, if the continuous line is above -2 and the number you entered was 12, change it to 10 on the front panel and tap **Finish**.

If all lines seem broken in a pattern, repeat the alignment.

You are recommended to reprint the diagnostic plot until all patterns are perfectly aligned.

Semi-automatic printhead alignment

Tools required

- HP OfficeJet Pro 7740 multi-function printer
- Single sheet of Tabloid or A3 paper
- Triphase to monophas power adaptor (if needed)

 **NOTE:** HP recommends setting up the HP OfficeJet Pro 7740 multi-function printer by following the instructions on the scanner front panel after it is first turned on. This step can be skipped for the semi-automatic printhead alignment.

Print the alignment plot

- At the front panel, tap  > **Utilities** > **Part quality troubleshooting** > **Perform semi-automatic alignment** > **Print alignment plot**.
- Open the top cover.

3. Take the calibration tool from the cleaning-roll cabinet door.

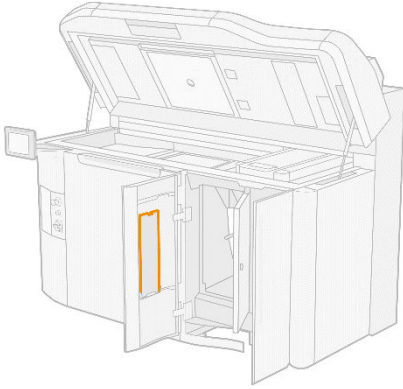

4. Take a single sheet of Tabloid or A3 paper and cut it in half lengthways.
5. Place the paper completely flat on the calibration tool, with the factory-cut edge lined up to the Tabloid/A3 alignment marks.

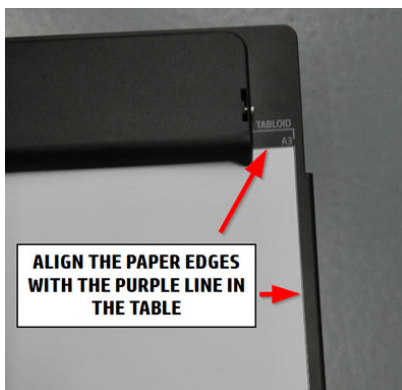

6. Install the calibration tool between the cleaning roll and the recoating unit.

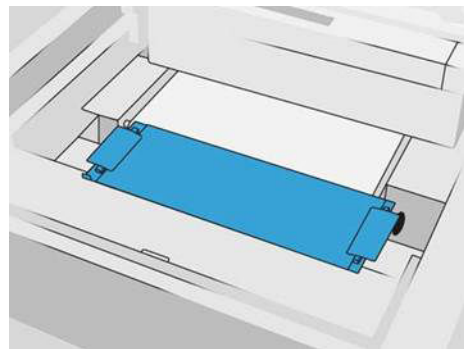
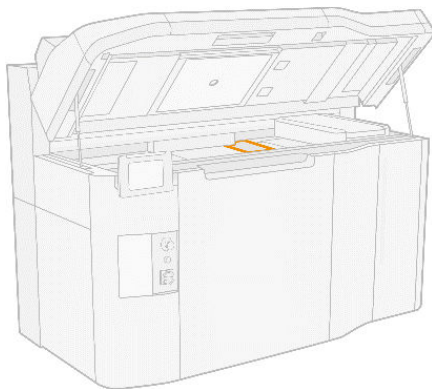

7. Tap **OK** to continue.
8. When the front panel indicates the plot is printed, open the top cover.
9. Remove the calibration tool from the printer and store it in the cleaning-roll door.
10. Keep the printed plot.
11. Close the top cover.
12. Tap any button to return to the menu and continue the process by launching the scan alignment plot (see below).

Scan the alignment plot

1. At the front panel, tap  > **Utilities** > **Part quality troubleshooting** > **Perform semi-automatic alignment** > **Scan alignment plot**.
2. Put the scanner close to the printer's front panel.
3. Plug the scanner into the power socket.
4. Plug the USB cable of the scanner into the printer's front panel.
5. Open the scanner cover.
6. Place the previously printed plot on the glass flatbed as described on the plot, positioning it at the top left corner of the scanner as shown below. The plot header should be oriented to the left.

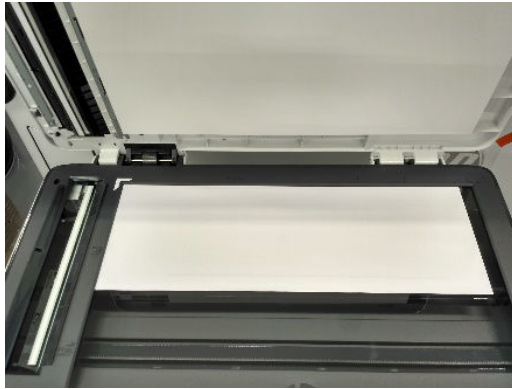

7. Close the scanner cover carefully: any air turbulence from the lid can move the plot on the scanning bed.
8. Tap **OK** on the front panel to start scanning.
9. When the scan is done, disconnect the scanner from the printer.
10. Tap any button to return to the menu.

Print the validation plot

1. At the front panel, tap  > **Utilities** > **Part quality troubleshooting** > **Perform semi-automatic alignment** > **Print validation plot**.
2. Open the top cover.
3. Take the calibration tool from the cleaning-roll cabinet door.

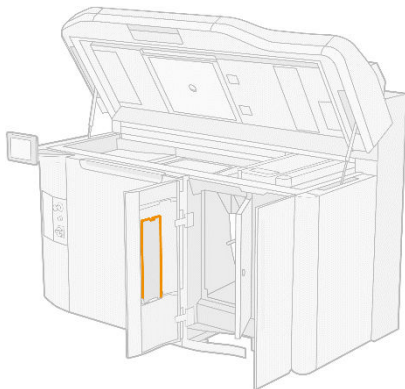

4. Take a single sheet of Tabloid or A3 paper and cut it in half lengthways.
5. Place the paper completely flat on the calibration tool, with the factory-cut edge lined up to the Tabloid/A3 alignment marks.

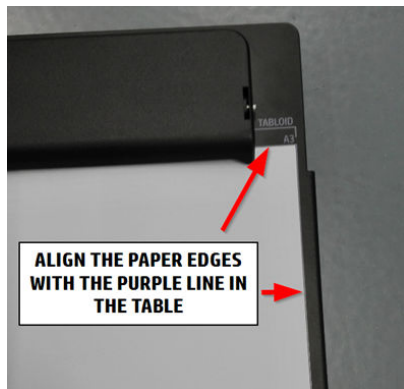

6. Install the calibration tool between the cleaning roll and the recoating unit.

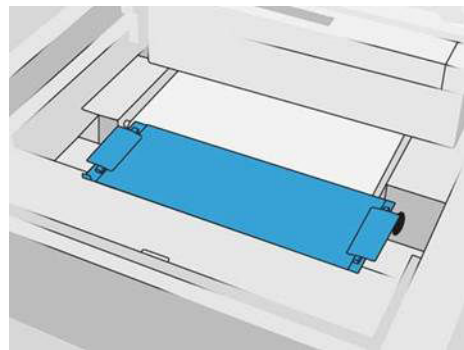
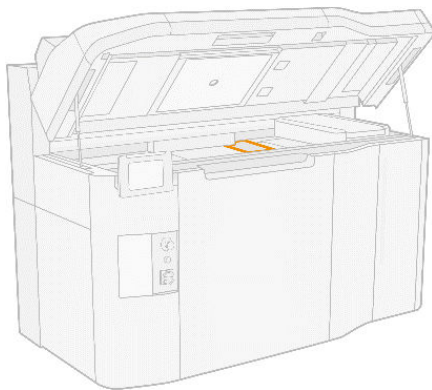

7. Tap **OK** to continue.
8. When the front panel indicates the plot is printed, open the top cover.
9. Remove the calibration tool from the printer and store it in the cleaning-roll door.
10. Keep the printed plot.
11. Close the top cover.
12. Tap any button to return to the menu and proceed to check the plot (see below).

Check the validation plot

 **IMPORTANT:** This plot is intended to provide you with visual information; the printed numbers are only for your information and will not be interpreted by the printer.

The following pattern is printed for each of the 15 dyes except the last. The pattern is designed with each line being composed of two little segments. Those segments have an induced incremental alignment error and are centered on the diamond (◆) and triangle (▲) positions.

The printhead is well aligned when all segments indicated by a diamond (◆) or a triangle (▲) are seen as a single continuous line. If the line is broken into two pieces, repeat the process of printhead alignment.

 **NOTE:** Not all the lines indicated by the diamond and triangle need to be perfectly aligned. A tolerance of ± 1 is accepted and is not a defect.

Well aligned examples

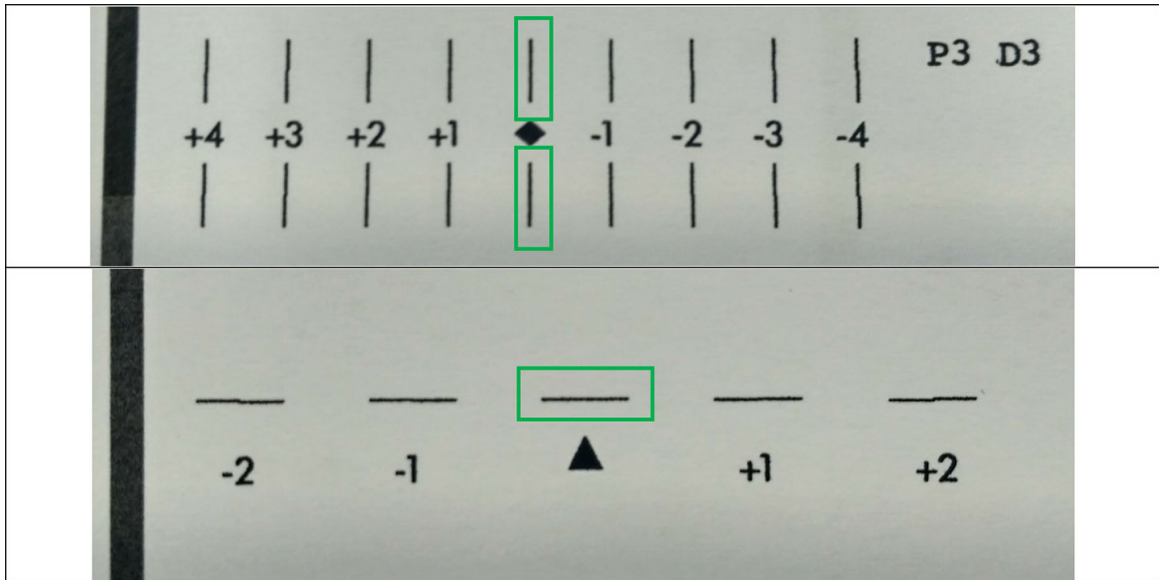

Poorly aligned examples

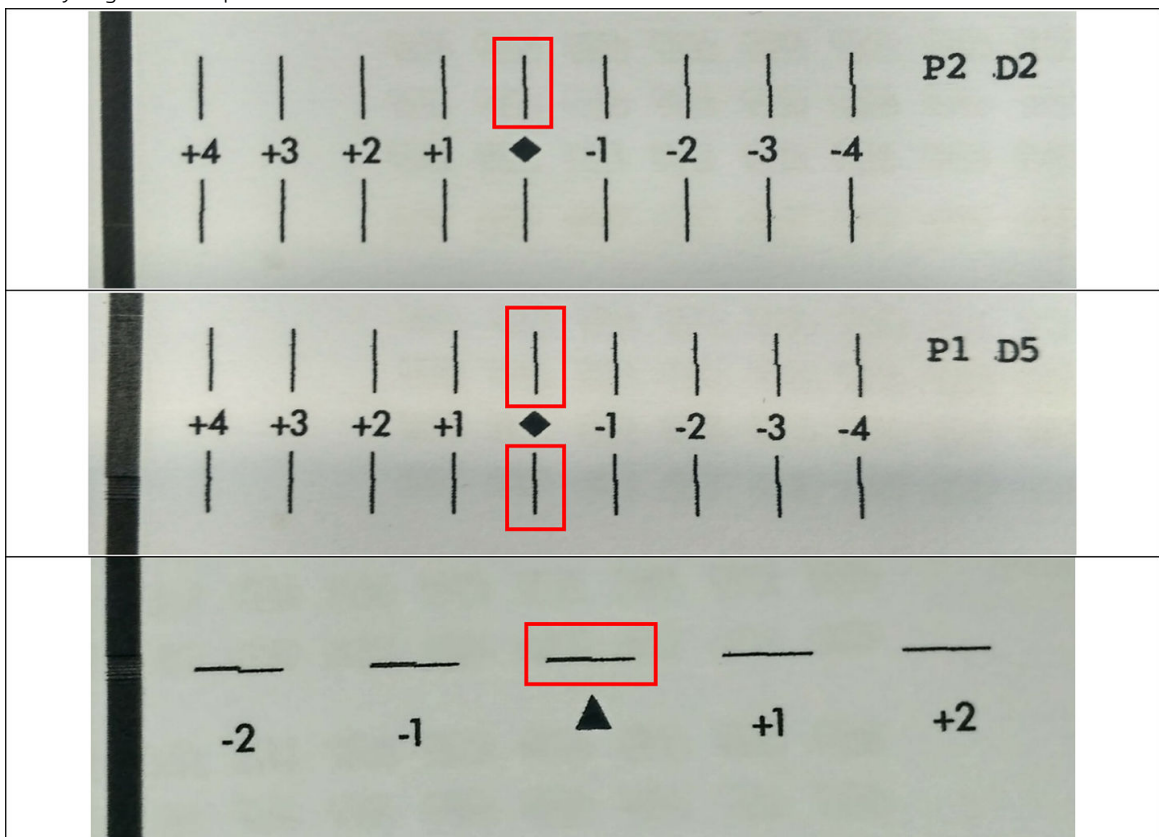

Troubleshooting

The printer may display the following message:

ERROR during the analysis of the plot, printheads are not aligned. The plot scanned will be displayed.

To respond to this message, read this section.

An example of a correctly scanned plot is shown below.

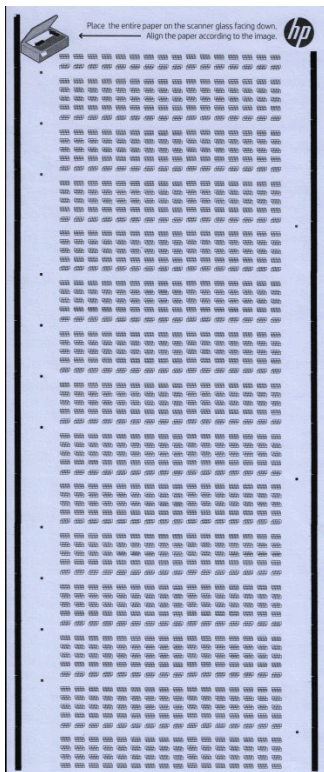

- If the image is blank, probably the printed plot is not present in the scanner, or it is facing up. Ensure that the plot is in the scanner, facing down, and aligned according to the instructions; then try again.
- If the scanned plot appears horizontally, probably the printed plot is rotated in the scanner. Ensure that the plot is aligned according to the instructions; then try again.

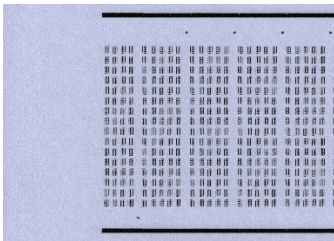

- If the scanned plot is clipped and not all of it is visible, probably the printed plot is not well aligned in the scanner. Ensure that the plot is aligned according to the instructions; then try again.
- If the scanned plot is smudged and shows ink smears, perhaps the printhead touched the paper while printing. Go back to the beginning and repeat the alignment plot, ensuring that the paper is perfectly flat on the calibration tool.
- If the scanned plot shows other quality defects, perform a printhead recovery (see [Recover \(clean\) the printheads on page 245](#)), then try again.
- If the scanned plot is tilted to one side, this could be because the printed plot is not well aligned in the scanner, or because the sheet of paper was not positioned correctly on the calibration tool when the print was made, or both. First ensure that the printed plot looks correct (not tilted); if necessary, go back to the beginning and reprint the alignment plot. Then ensure that the plot is aligned according to the instructions; then try again.

If these suggestions do not solve the problem, contact your service representative.

Printhead Health Gauge front-panel messages

Message descriptions and actions

The printhead Health Gauge is shown in several places in the front panel. For example, you can always check it on the printhead detailed information screen.

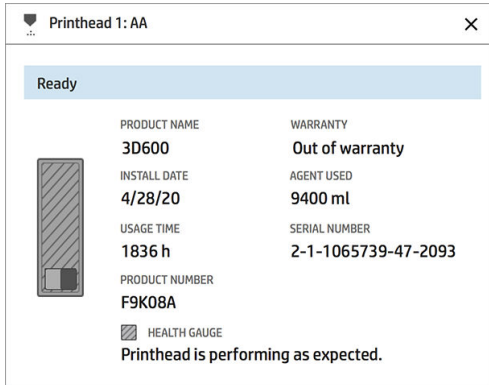

The printhead Health Gauge has three levels:

- There is no problem with the printhead nozzles.

 HEALTH GAUGE
Printhead is performing as expected.

- The printhead has relatively few clogged nozzles. This is unlikely to produce any defects in the printed parts, but it could happen.

 HEALTH GAUGE
Printhead has clogged nozzles.
Part quality may be affected. Consult user guide: [Print-quality optimization > Printhead health troubleshooting.](#)

- The printhead has more clogged nozzles, which may produce defects in the printed parts.

 HEALTH GAUGE
Printhead is underperforming.
Part quality is likely to be affected. Consult user guide: [Print-quality optimization > Printhead health troubleshooting.](#)

Troubleshooting

There are two main tools for investigating clogged nozzles:

- Check the nozzle status screen. See [Nozzle status on page 239](#).
- Print the printhead status plot (for fusing-agent nozzles only). See [Print the printhead status plot on page 240](#).

Nozzle status

To view the nozzle status, go to the front panel and tap , then **System tools > Drop-detector utilities > Show nozzle status**. The following screen appears.

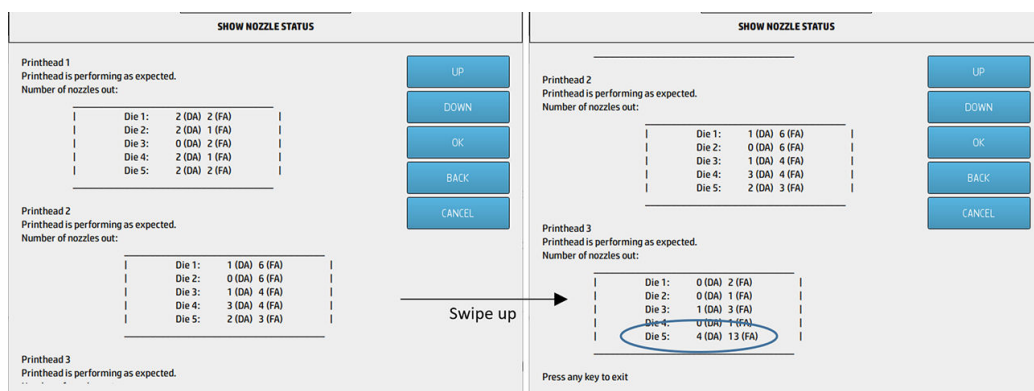

The lists show the number of clogged nozzles in each die for each agent, Detailing Agent (DA) and Fusing Agent (FA).

For example, in the above example, the die that is closest to the front of the printer, which is Printhead 3, Die 5, has 4 clogged nozzles in the Detailing Agent and 13 clogged nozzles in the Fusing Agent (blue balloon).

How the Health Gauge relates to the number of clogged nozzles

The following table summarizes the relation between clogged nozzles and the Health Gauge.

Bear in mind that the analysis in the printer is more thorough, and takes more into account than just the number of clogged nozzles.

Clogged nozzles	Health Gauge message	Action
0–99	Printhead is performing as expected	None needed
100–119	Transition to Printhead has clogged nozzles	When convenient (between jobs), see What to do when the printheads show these defects on page 244
120–149	Probably Printhead has clogged nozzles	
150–169	Transition to Printhead is underperforming	See What to do when the printheads show these defects on page 244
170+	Probably Printhead is underperforming	

Any time the number of clogged nozzles in one or more dies/agents in one printhead is more than 900 (maximum is 1056), it is very unlikely that so many nozzles became clogged suddenly. Therefore, these are the possible causes:

- They could be genuine clogged nozzles after some damaging event such as, for example, the carriage crashing into the material. In this case, follow the guidelines in [What to do when the printheads show these defects on page 244](#).
- There could be a problem with the drop-detector calibration. Tap , then **System tools > Calibrations > Drop-detector calibration**.
- There could be a connection problem in the affected printhead. Try reseating the affected printhead, see [Replace a printhead on page 44](#) (after removing the printhead, you can reinsert the same printhead).

After these actions, run a printhead recovery 1 routine to force a health status update. See [Recover \(clean\) the printheads on page 245](#).

If all else fails, replace the printhead with a new one. If that also fails, contact your service representative.

Print the printhead status plot

You can use the printhead status plot to assess printhead nozzle health.

At the front panel, tap , then **Part quality troubleshooting > Printhead status plot**, then follow the instructions on the front panel.

The printhead status plot is printed, as shown below.

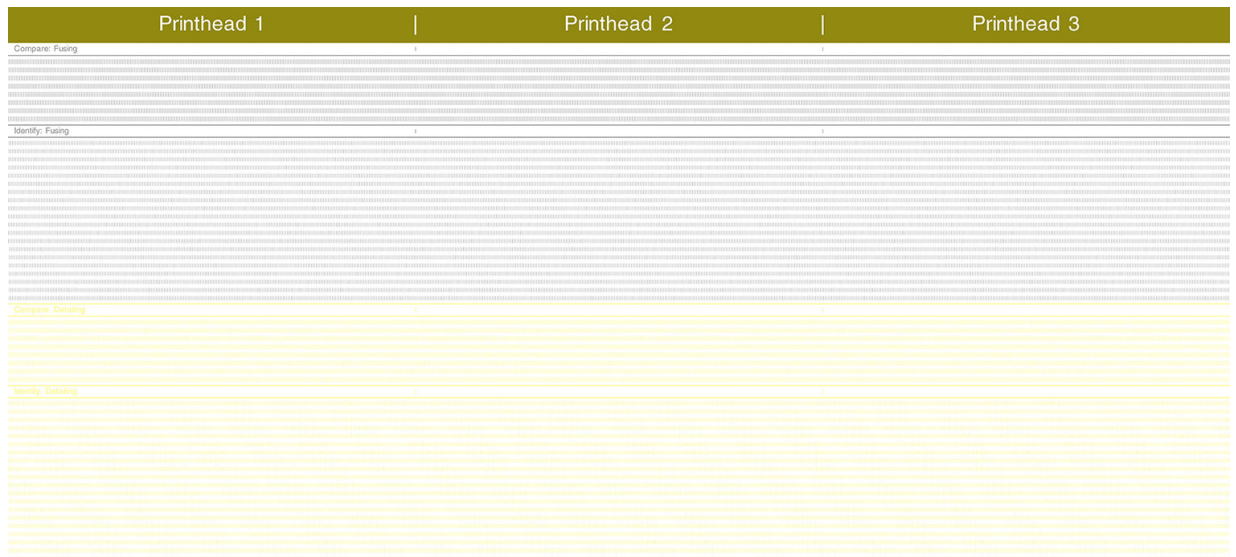

 **NOTE:** The detailing agent, shown in yellow in the above image, is not normally visible. However, it may sometimes appear partially in a very light shade of gray.

How to interpret the printhead status plot

Use a 10× magnifier to look at the plot. There are patterns corresponding to each of the printheads, Printhead 1, Printhead 2, and Printhead 3.

Each of these has two sections: Compare and Identify.

Compare: Fusing

This section shows isolated (or individual) nozzles. You can use it to assess by inspection the percentage of random nozzles out in an area of a printhead.

 0 -20%

 20 -30%

 30+%

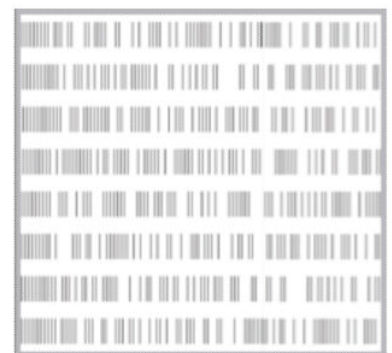
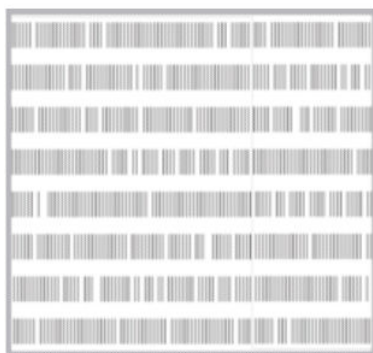

Random nozzles out have a much lower impact on mechanical properties than consecutive nozzles out.

It is not easy to estimate the percentage of nozzles out visually; therefore some aids are provided in the table below.

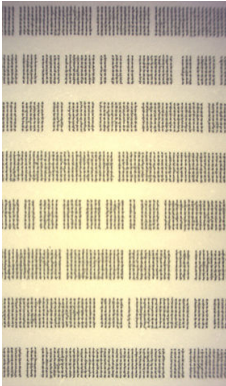
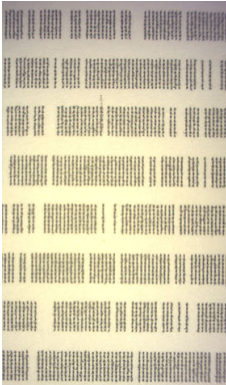
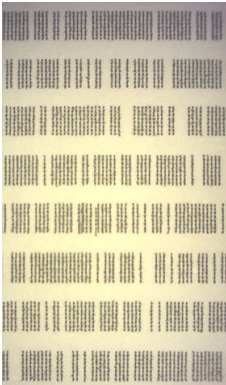
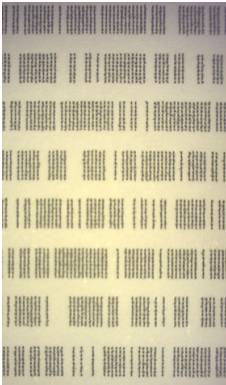
Nozzles out	Effect on mechanical properties	View
10%	No risk of defects	
15%	No risk of defects	
20%	Low risk of defects	
25%	Low risk of defects	

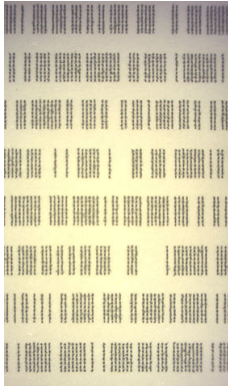
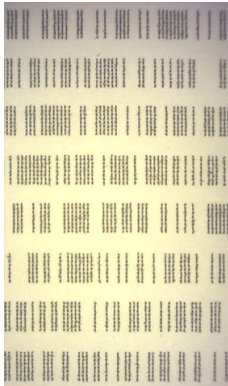
Nozzles out	Effect on mechanical properties	View
30%	High risk of defects	
40%	High risk of defects	



Identify: Fusing

This section shows small groups of consecutive nozzles. A group of more than a certain number of consecutive nozzles out can produce a flaw in the part.

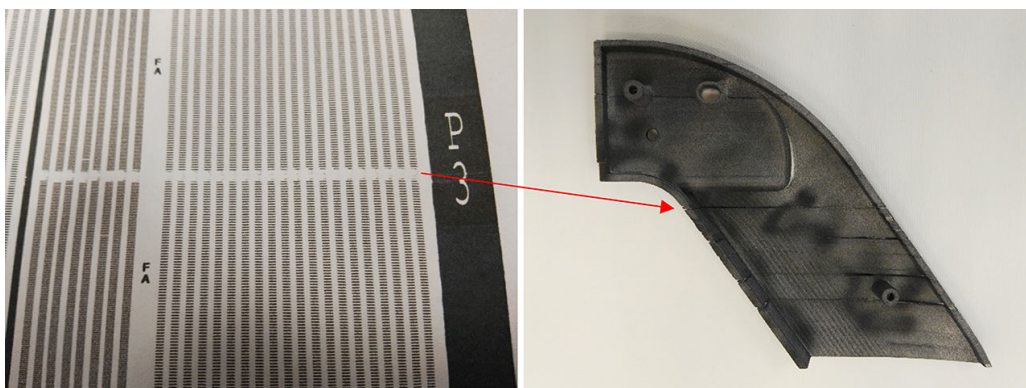
This type of flaw in a fusing agent can produce bad mechanical properties. If there are a number of consecutive fusing-agent nozzles out, covering 1 mm or more (for example), the parts printed in that area will come out of the build unit severely damaged or even split in two.

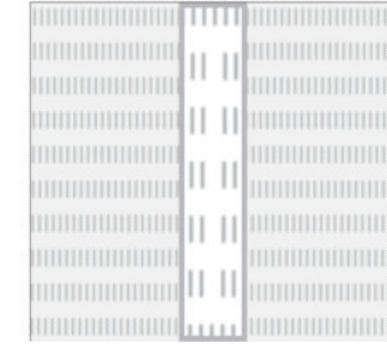
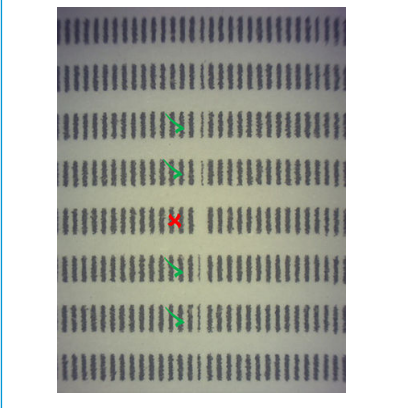
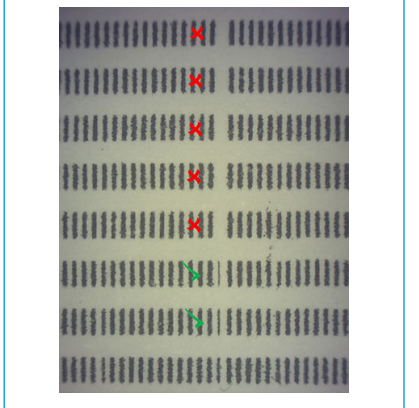

You are more likely to see a small number of consecutive nozzles out. The identify pattern allows you to check in which areas there could be a problem and decide whether the number of consecutive missing nozzles could produce defects. The table below summarizes the impact.

✓ none missing	! 1 - 4 missing	✗ 5+ missing
		
	Low risk of impact on mechanical properties: 1 to 4 sequential groups missing (1 shown)	High risk of impact on mechanical properties: 5 or more sequential groups missing (5 shown)
		

What to do when the printheads show these defects

1. Try to recover the affected printhead(s).

See [Recover \(clean\) the printheads on page 245](#). Start with the recovery 1 operation, then reprint the printhead status plot to check the effect. If you are still seeing defective nozzles, try the recovery 2 operation.

2. Rearrange the parts.

If possible, this is sometimes very straightforward. Simply move the parts of the next job to positions in the print bed that will not be affected by the defective nozzles.

An example is shown below. The yellow lines represent areas with possible defects; the red lines represent areas with probable defects; the blue ellipses enclose parts affected by the defective nozzles. On the left, a number of parts are affected by yellow and red lines; on the right, the parts have been rearranged so that only one part is affected by a yellow line.

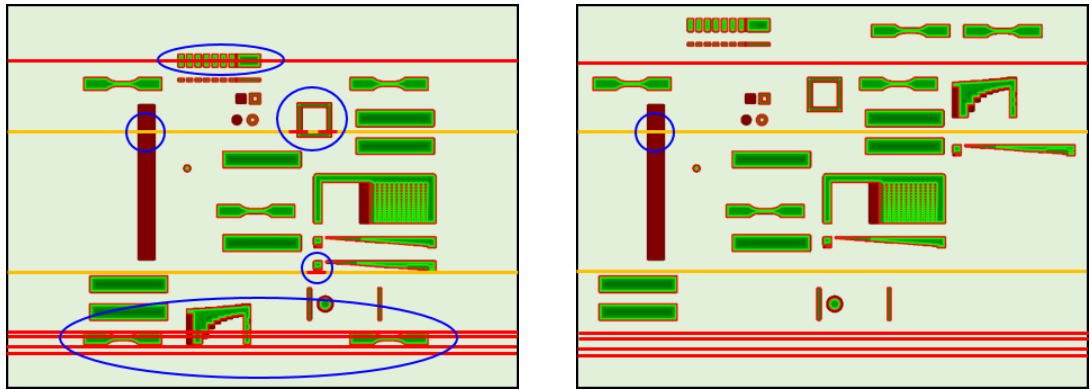

For reference, the location of each printhead and die with respect to the bed is shown below.

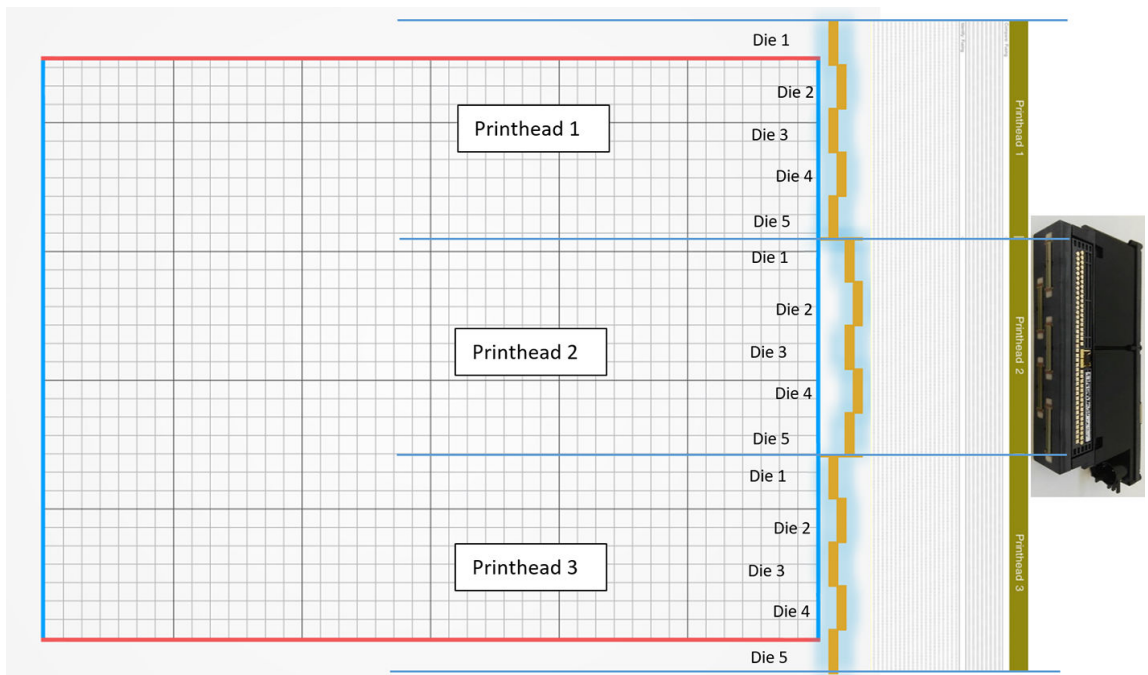

3. Replace the affected printhead(s).

If the printhead recovery is not sufficiently effective, you can choose to replace a malfunctioning printhead with a new one.

Recover (clean) the printheads

The printer can try to recover the use of a malfunctioning printhead by cleaning it. At the front panel, tap .

then **Part quality troubleshooting > Printhead recovery 1**. If the initial recovery is not completely successful, you can try **Printhead recovery 2**.

Airflow check

For optimal printer performance, the ambient temperature should be maintained within the specified range (see the site preparation guide), and the airflow into and out of the printer should be unimpeded.

- Make sure that the print-zone inlet (behind the printer) is not blocked by any obstruction.
- Make sure that the fans on top of the printer are not blocked by any obstruction.

14 Ordering information

This chapter lists the available supplies and accessories, and their part numbers, at the time of writing.

Contact your support representative and check that what you want is available in your area and for your model.

Part number	Name
3FW29A	HP Jet Fusion 5200 3D Build Unit
6ER17A (virtual)	HP Jet Fusion 5210 Pro 3D Build Unit
4QG10A	HP Jet Fusion 5200 3D Series Natural Cooling Kit
4QG11A	HP Jet Fusion 5200 3D Series Automatic External Tank Starter Kit
5ZR19A	HP Jet Fusion 5210 3D Printer Installation Kit
5ZR20A	HP Jet Fusion 5210 3D Processing Station Installation Kit
5ZR21A	HP Jet Fusion 5200 3D Semaphore
5ZR22A	HP Jet Fusion 5200 3D RFID Module
5ZR23A	HP Jet Fusion 5210 Pro 3D Printer Installation Kit
5ZR24A	HP Jet Fusion 5210 Pro 3D Processing Station Installation Kit
F9K08A	HP 3D600 Printhead
V1Q77A	HP 3D710 Printhead (only for 5210)
V1Q60A	HP 3D600 3-liter Fusing Agent
V1Q63A	HP 3D700 5L Fusing Agent
V1Q78A	HP 3D710 5L Fusing Agent (only for 5210)
V1Q61A	HP 3D600 3-liter Detailing Agent
V1Q64A	HP 3D700 5L Detailing Agent
V1Q79A	HP 3D710 5L Detailing Agent (only for 5210)
V1Q66A	HP 3D600 Cleaning Roll
V1R10A	HP 3D HR PA 12 30 L / 13 kg Material
V1R12A	HP 3D HR PA 11 30 L / 14 kg Material
V1R16A	HP 3D HR PA 12 300 L / 130 kg Material
V1R18A	HP 3D HR PA 11 300 L / 140 kg Material
V1R34A	HP 3D HR PA 12 300 L / 130 kg P Material
V1R36A	HP 3D HR PA 11 300 L / 140 kg P Material
V1R20A	HP 3D HR PA 12 1400 L / 600 kg Material

15 System errors

- [Introduction](#)
- [0051-0008-0001 Mixer loading nozzle sensor PCA malfunction](#)
- [0085-0008-0X94 Carriage – Printhead – Temperature extremely high](#)
- [0085-0008-0X86 Carriage – Printhead – Temperature too high](#)
- [0085-0008-0X95 Carriage – Printhead – Temperature extremely low](#)
- [0085-0008-0X87 Carriage – Printhead – Temperature too low](#)
- [0085-0008-0X82 Carriage – Printhead – Data not responding](#)
- [0085-0008-0X98 Carriage – Printhead – Transmit error](#)
- [0085-0008-0X96 Carriage – Printhead – Energy calibration failure](#)
- [0085-0008-0X93 Carriage – Printhead – Fails continuity](#)
- [0085-0008-0X85 Carriage – Printhead – Fails logical](#)
- [0085-0008-0X10 Carriage – Printhead – Voltage out of range](#)
- [0085-0013-0X01 Carriage – Primer – Malfunction](#)
- [0085-0013-0X33 Carriage – Primer – Current too high](#)
- [0085-0013-0X41 Carriage – Primer – Leakage](#)
- [809C-D706-0000](#)

Introduction

The system may occasionally display a system error, consisting of a numerical code of 12 digits followed by the recommended action that you should take.

In most cases you will be asked to restart the equipment. When the printer or processing station starts, it can diagnose the issue better and may be able to fix it automatically. If the problem persists after restarting, contact your support representative and be ready to give the numerical code from the error message.

Instructions for some specific messages are given below. In other cases, follow the instructions in the message.

In every error code, the printheads are numbered as shown below:

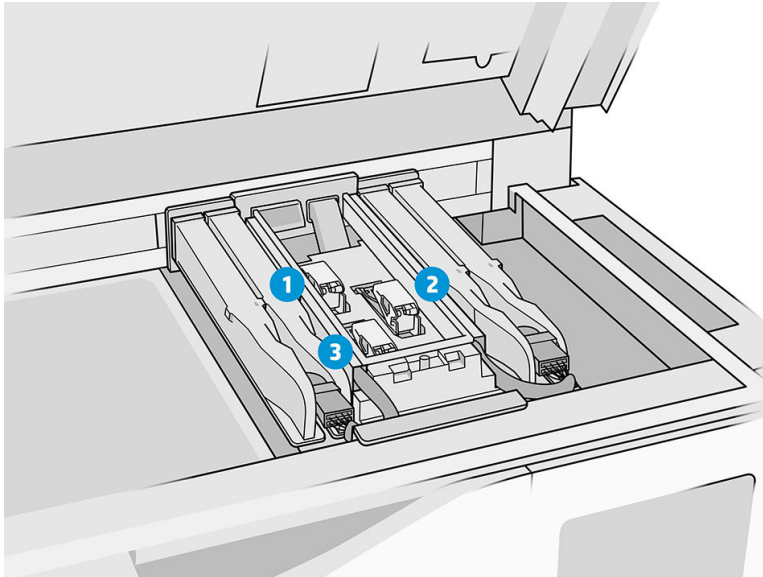

1. Rear printhead
2. Middle printhead
3. Front printhead

0051-0008-0001 Mixer loading nozzle sensor PCA malfunction

1. Check that the nozzle sensor is clean.
2. Turn the processing station off and then on again.
3. Try again to load the material into the build unit.
4. If the problem persists, contact your service representative.

0085-0008-0X94 Carriage – Printhead – Temperature extremely high

(0085-0008-0194, 0085-0008-0294, 0085-0008-0394)

Where X is the number of the printhead.

1. Remove the printhead and weigh it. If it weighs less than 255 g, replace it: see [Replace a printhead on page 44](#). If the weight is correct, continue with the following steps.
2. Clean the printhead contacts: see [Clean the printhead contacts on page 159](#).

3. If the problem persists, swap the printhead with another to check whether the problem moves to the new location of the original printhead. If this is the case, replace the printhead: see [Replace a printhead on page 44](#).
4. Look in the software for job sections that are too dense, and try to change the orientation. Start with a small area to fuse and also finish with a small area to print/fuse, if you are faced with abraded tops or sinks. This can easily be achieved by rotating the part at a certain angle: HP recommends rotating the part more than 20 degrees to minimize stair-stepping.

0085-0008-0X86 Carriage – Printhead – Temperature too high

(0085-0008-0186, 0085-0008-0286, 0085-0008-0386)

Where X is the number of the printhead.

1. Remove the printhead and weigh it. If it weighs less than 255 g, replace it: see [Replace a printhead on page 44](#). If the weight is correct, continue with the following steps.
2. Look in the software for job sections that are too dense, and try to change the orientation.

0085-0008-0X95 Carriage – Printhead – Temperature extremely low

(0085-0008-0195, 0085-0008-0295, 0085-0008-0395)

Where X is the number of the printhead.

1. Clean the printhead contacts: see [Clean the printhead contacts on page 159](#).
2. If the problem persists, swap the printhead with another to check whether the problem moves to the new location of the original printhead. If this is the case, replace the printhead: see [Replace a printhead on page 44](#).

0085-0008-0X87 Carriage – Printhead – Temperature too low

(0085-0008-0187, 0085-0008-0287, 0085-0008-0387)

Where X is the number of the printhead.

1. Clean the printhead contacts: see [Clean the printhead contacts on page 159](#).
2. If the problem persists, swap the printhead with another to check whether the problem moves to the new location of the original printhead. If this is the case, replace the printhead: see [Replace a printhead on page 44](#).

0085-0008-0X82 Carriage – Printhead – Data not responding

(0085-0008-0182, 0085-0008-0282, 0085-0008-0382)

Where X is the number of the printhead.

1. Clean the printhead contacts: see [Clean the printhead contacts on page 159](#).
2. If the problem persists, swap the printhead with another to check whether the problem moves to the new location of the original printhead. If this is the case, replace the printhead: see [Replace a printhead on page 44](#).

0085-0008-0X98 Carriage – Printhead – Transmit error

(0085-0008-0198, 0085-0008-0298, 0085-0008-0398)

Where X is the number of the printhead.

1. Clean the printhead contacts: see [Clean the printhead contacts on page 159](#).
2. If the problem persists, swap the printhead with another to check whether the problem moves to the new location of the original printhead. If this is the case, replace the printhead: see [Replace a printhead on page 44](#).

0085-0008-0X96 Carriage – Printhead – Energy calibration failure

(0085-0008-0196, 0085-0008-0296, 0085-0008-0396)

Where X is the number of the printhead.

1. Clean the printhead contacts: see [Clean the printhead contacts on page 159](#).
2. If the problem persists, swap the printhead with another to check whether the problem moves to the new location of the original printhead. If this is the case, replace the printhead: see [Replace a printhead on page 44](#).

0085-0008-0X93 Carriage – Printhead – Fails continuity

(0085-0008-0193, 0085-0008-0293, 0085-0008-0393)

Where X is the number of the printhead.

1. Clean the printhead contacts: see [Clean the printhead contacts on page 159](#).
2. If the problem persists, swap the printhead with another to check whether the problem moves to the new location of the original printhead. If this is the case, replace the printhead: see [Replace a printhead on page 44](#).

0085-0008-0X85 Carriage – Printhead – Fails logical

(0085-0008-0185, 0085-0008-0285, 0085-0008-0385)

Where X is the number of the printhead.

1. Clean the printhead contacts: see [Clean the printhead contacts on page 159](#).
2. If the problem persists, swap the printhead with another to check whether the problem moves to the new location of the original printhead. If this is the case, replace the printhead: see [Replace a printhead on page 44](#).

0085-0008-0X10 Carriage – Printhead – Voltage out of range

(0085-0008-0110, 0085-0008-0210, 0085-0008-0310)

Where X is the number of the printhead.

1. Clean the printhead contacts: see [Clean the printhead contacts on page 159](#).
2. If the problem persists, swap the printhead with another to check whether the problem moves to the new location of the original printhead. If this is the case, replace the printhead: see [Replace a printhead on page 44](#).

0085-0013-0X01 Carriage – Primer – Malfunction

Where X is:

1. Primer on Printhead 1
2. Primer on Printhead 2
3. Primer on Printhead 3

The primer is wrongly connected or its cable is broken. Just disconnect the primer cable and reconnect it. See [Replace a primer on page 172](#), step 1 to disconnect the primer cable and step 4 to reconnect it.

If the problem persists after fixing the connection, it is also possible that the primer itself is broken. In this case, replace the corresponding primer. See [Replace a primer on page 172](#).

0085-0013-0X33 Carriage – Primer – Current too high

Where X is:

1. Primer on Printhead 1
2. Primer on Printhead 2
3. Primer on Printhead 3

The primer is broken. Replace the corresponding primer. See [Replace a primer on page 172](#).

0085-0013-0X41 Carriage – Primer – Leakage

Where X is:

1. Primer on Printhead 1
2. Primer on Printhead 2
3. Primer on Printhead 3

There is a leak in the primer air circuit. The most probable cause is that the primer ports were wrongly inserted when latching the printhead. Re-latch the corresponding printhead.

The primer ports are two small air ports below the latch that must fit into the two top printhead holes.

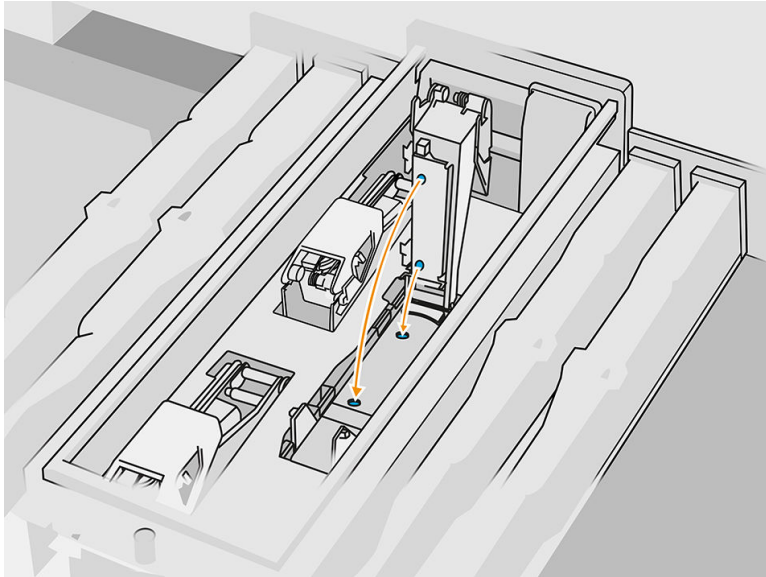

See [Replace a printhead on page 44](#), steps 5 and 6 to release and lift the latch, step 12 and 13 to ensure primer ports are well inserted, and step 14 to close it.

 **IMPORTANT:** Just lift the latch and close it; do not extract the printhead.

If the problem persists after re-latching the printhead, it is also possible that the primer ports are broken or the primer circuit itself leaks. In this case, replace the corresponding primer. See [Replace a primer on page 172](#).

809C-D706-0000

1. Ensure that the external tank connector is correctly connected and that the sieve, mixer, and internal tank lids are properly closed.
2. Turn the processing station off and then on again.

16 When you need help

Request support

Support is provided by your support representative: usually from the company from which you bought the printer. If this is not the case, contact HP Support on the Web:

- <http://www.hp.com/go/jetfusion3D5200/support>, or
- <http://www.hp.com/go/jetfusion3D5210/support>, or
- <http://www.hp.com/go/jetfusion3D5210pro/support>, or
- <http://www.hp.com/go/jetfusion3Dprocessingstation/support>

Before calling your support representative, prepare for the call as follows:

- Review the troubleshooting suggestions in this guide.
- Review your software documentation, if relevant.
- Check that you have the following information ready:
 - The product and serial numbers of the printer you are using.
 - If there is an error code on the front panel, make a note of it. See [System errors on page 256](#).
 - The name and version number of your software.
 - If you have a print-quality problem, the name and product number of the paper, and the name and origin of the paper preset that you used to print on it.

Customer Self-Repair

HP's Customer Self-Repair program offers our customers the fastest service under either warranty or contract. It enables HP to ship replacement parts directly to you (the end user) so that you can replace them. Using this program, you can replace parts at your own convenience.

Convenient and easy to use

- Your support representative will diagnose and assess whether a replacement part is required to address a defective hardware component.

For more information about Customer Self Repair, see <http://www.hp.com/go/selfrepair/>.

Service information

The Command Center can produce on request a list of many aspects of the printer's current status, some of which may be useful to a service engineer trying to fix a problem.

17 Accessibility

Front panel

If required, the front-panel display brightness and the loudspeaker volume can be changed (see [Change system options on page 24](#)).

Index

A

- administrator password 25
- agents 40
 - replace 41
 - troubleshoot 43
- air conditioning 10
- air extraction 11
- airflow check 246
- alerts 23

B

- balanced print profile 246
- beacon 24
- Build Manager 31
- build-unit components 21
- build-unit maintenance 221

C

- cartridges 56
 - maintain 66
 - replace 57
 - store 66
 - troubleshoot 66
- cautions 12
- circuit-breaker labels 35
- cleaning 118
- Command Center 26
- cosmetic print profile 253
- CSR 262
- customer self-repair 262

D

- documentation 2

E

- emergency stop buttons 16
- errors, system 256
- external tank 67
- extraction system 11

F

- fast cooling
 - considerations 82

- fast print profile 252
- file preparation 70
- front panel 22
- front panel option
 - display brightness 24
 - speaker volume 24
 - unit selection 25
- front-panel options
 - date and time options 24
 - restore factory settings 25

H

- help 262
- hostname 37

J

- job
 - add while printing 105
 - cancel 106
 - check status 107
 - create 70
 - errors 107
 - file preparation 70
 - select 105
 - send 105
 - status 105

L

- labels
 - circuit breakers 35
 - warning 13

M

- maintenance 119
 - build unit 221
 - kits 120
 - printer 126
 - processing station 203
 - tools 123
- manuals 2
- material 56
 - load into build unit 89
- mechanical print profile 253

- MJF technology 2
- Multi Jet Fusion 2

N

- network troubleshooting 38
- networking 36

O

- options, system 24
- order supplies 255

P

- part
 - accuracy 79
 - clean 118
 - contraction 78
 - curved surfaces 80
 - engraving 80
 - final production 81
 - gap 81
 - mechanical properties 80
 - orientation 79
 - orientation flowcharts 81
 - positioning 80
 - postprocess 118
 - protection 82
 - repeatability 81
 - sharp surfaces 80
 - specifications 74
 - stepping 79
 - troubleshoot 230
 - warping 80
- part numbers 255
- password
 - administrator 25
- postprocessing 118
- print modes 108
- print profile
 - balanced 246
 - characteristics 253
 - cosmetic 253
 - fast 252
 - mechanical 253

- printer components 18
- printer maintenance 126
- printer on/off 33
- printhead cleaning roll 48
 - replace 48
- printheads 43
 - align 230
 - clean 245
 - Health Gauge messages 239
 - recover 245
 - replace 44
 - status plot 240
- printing 104
- printing process outline 4
- processing station on/off 34
- processing-station components 20
- processing-station maintenance 203

R

- recycle supplies 68
- Rhinoceros settings 71

S

- safety labels 13
- safety precautions 5
- service information 262
- sinter box 82
- SmartStream 3D
 - Build Manager 31
 - Command Center 26
- software 26
- Solid Designer settings 70
- SolidWorks settings 71
- status center 23
- STL file repairs 72
- STL problems 71
- storage tank 67
- support 262
- system options 24

T

- tank 67
- tesselation 70
- tools 12

U

- unpacking 109

V

- ventilation 10

W

- warning labels 13
- warnings 12