

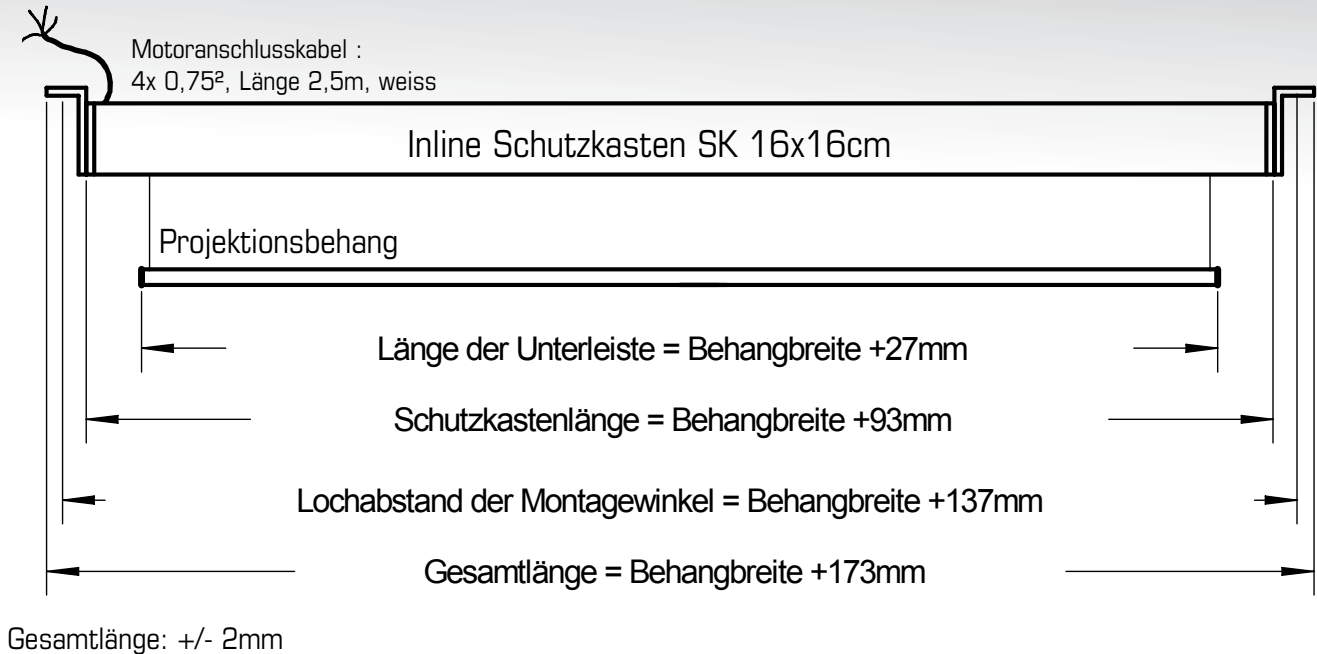

INLINE 160 MW MONTAGEWINKEL



Abmessungen der Projektionswand



Querschnitt Inline-Schutzkasten

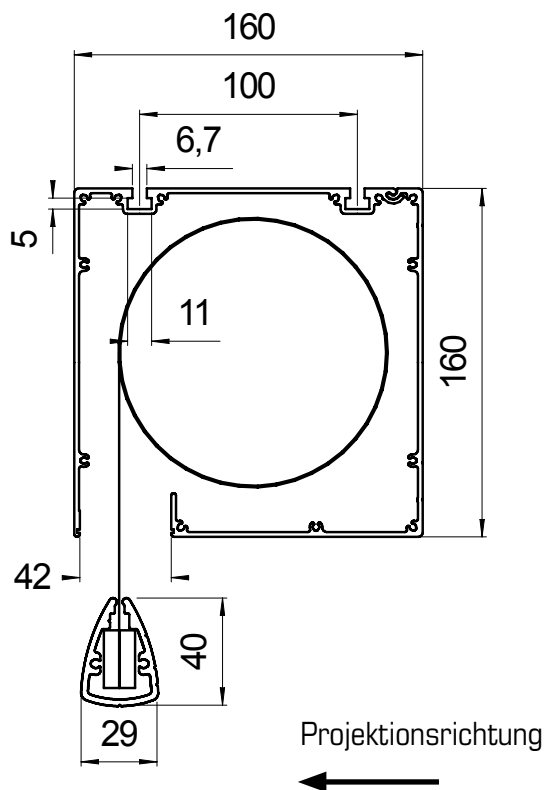

Universal - Montagewinkel

für Wand und Deckenmontage

