

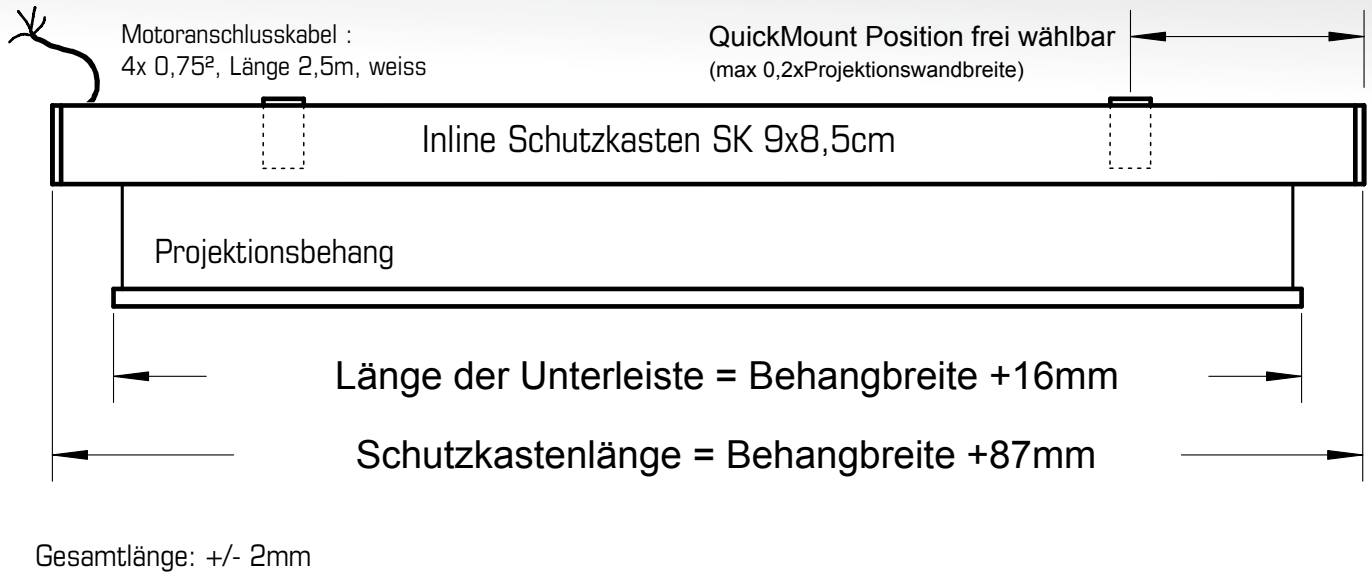

INLINE 90 QM QuickMount



Abmessungen der Projektionswand



Querschnitt Inline-QuickMount

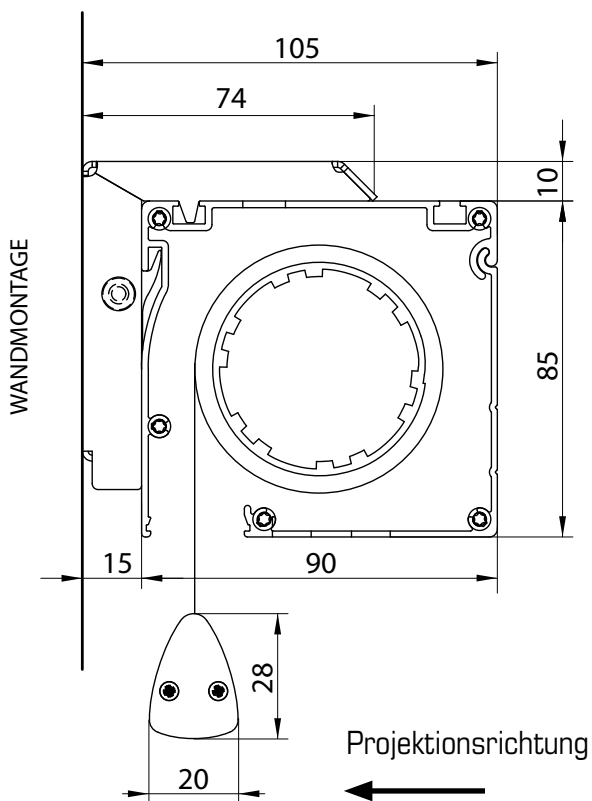

QuickMount Montagewinkel

für Wand und Deckenmontage

