

MXV Dual Monitor Arm with C-Clamp (under mount)

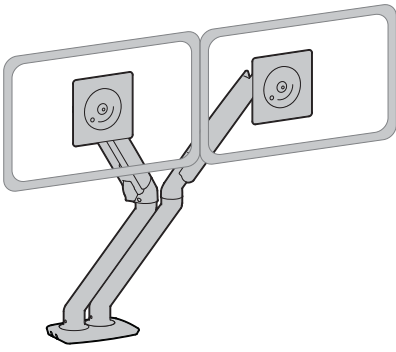

Monitor Interface Bracket

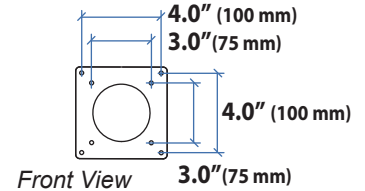

Dimensions

Arm in full up position: **20.2"** (514 mm)
 Arm at max extension: **23.3"** (590 mm)
 Arm in full down position: **20.7"** (526 mm)
 Arm in full up position: **8.2"** (211 mm)
 Arm at max extension: **11.3"** (287 mm)
 Arm in full down position: **8.7"** (223 mm)

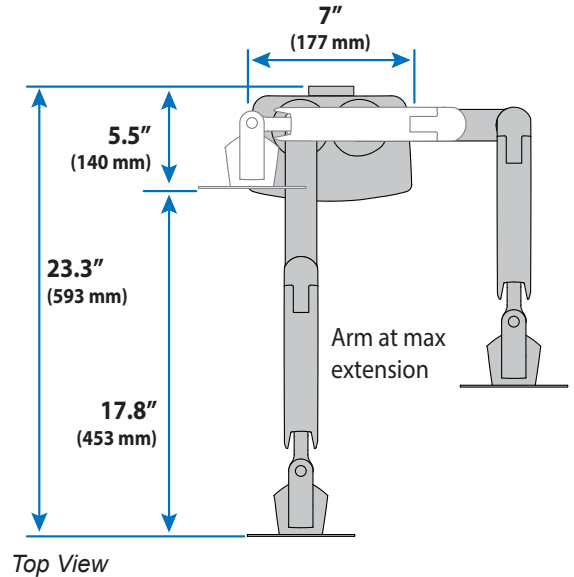
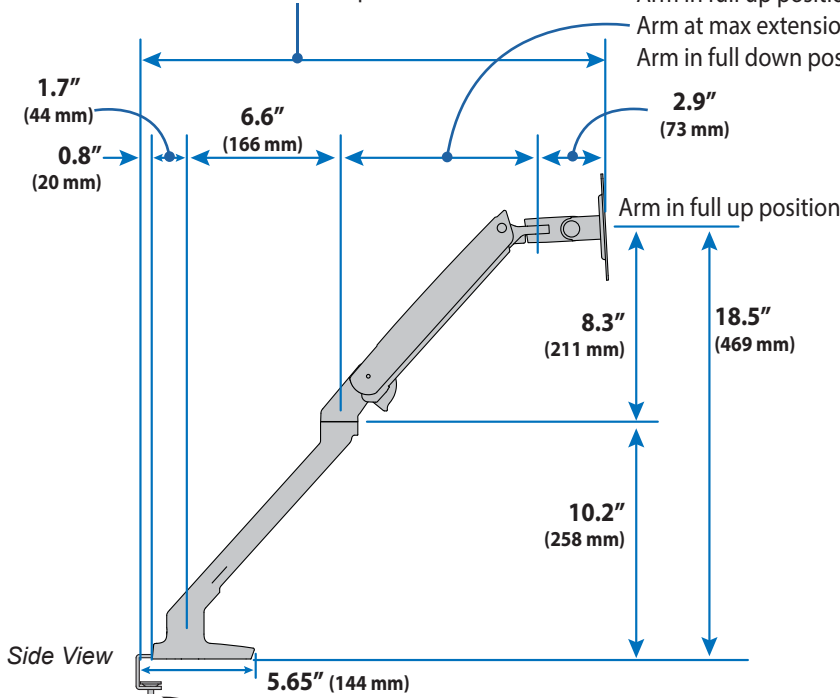

Desk Thickness

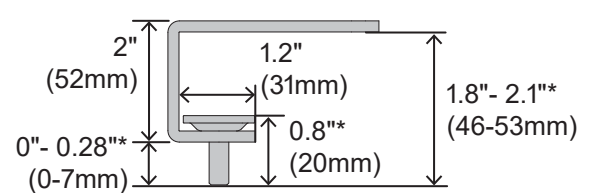
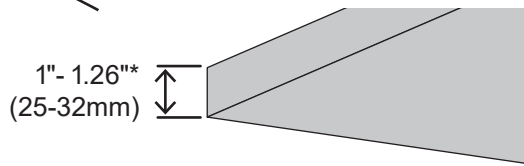

*Optional longer screws can be added for thinner desks:

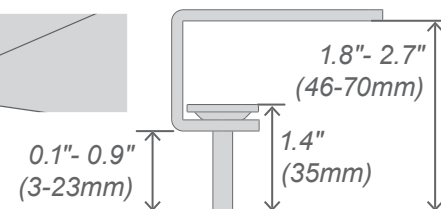

© 2017 Ergotron, Inc. rev. 01/072019 DIM-MXVdual-Cclamp Content is subject to change without notification

Americas Sales and Corporate Headquarters

St. Paul, MN USA
(800) 888-8458
+1-651-681-7600
www.ergotron.com
sales@ergotron.com

EMEA Sales

Amersfoort, The Netherlands
+31 33 45 45 600
www.ergotron.com
info.eu@ergotron.com

APAC Sales

Tokyo, Japan
www.ergotron.com
japansupport@ergotron.com

Worldwide OEM Sales

www.ergotron.com
info.oem@ergotron.com



MXV Dual Monitor Arm

with C-Clamp (under mount)

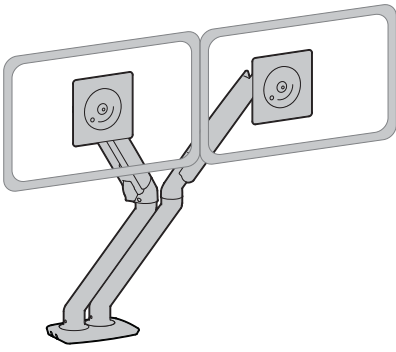

Dimensions

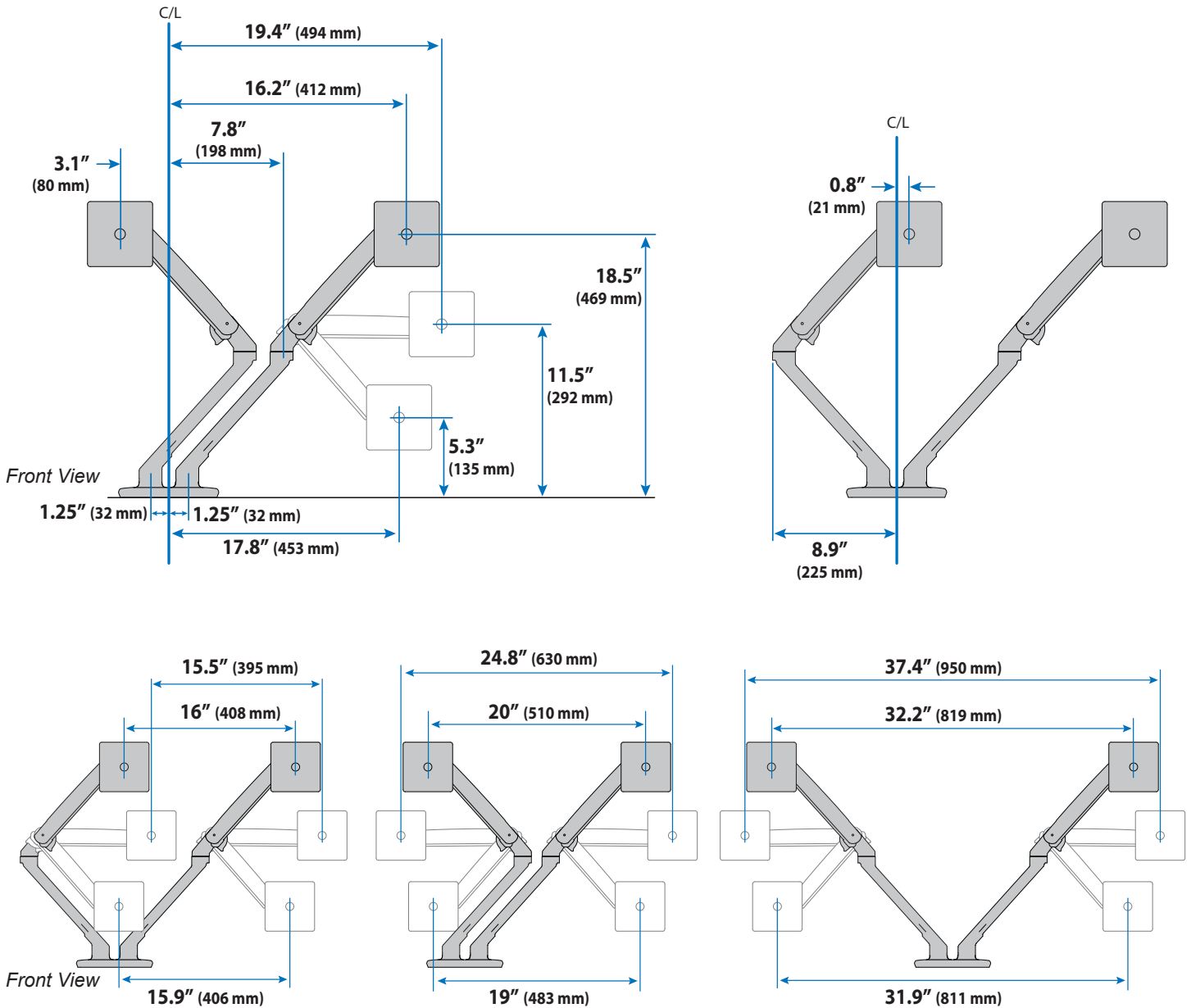

© 2017 Ergotron, Inc. rev. 01/072019 DIM-MXVdual-Cclamp **Content is subject to change without notification**

Americas Sales and Corporate Headquarters

St. Paul, MN USA
 (800) 888-8458
 +1-651-681-7600
 www.ergotron.com
 sales@ergotron.com

EMEA Sales

Amersfoort, The Netherlands
 +31 33 45 45 600
 www.ergotron.com
 info.eu@ergotron.com

APAC Sales

Tokyo, Japan
 www.ergotron.com
 japansupport@ergotron.com

Worldwide OEM Sales

www.ergotron.com
 info.oem@ergotron.com



MXV Dual Monitor Arm

with C-Clamp (under mount)

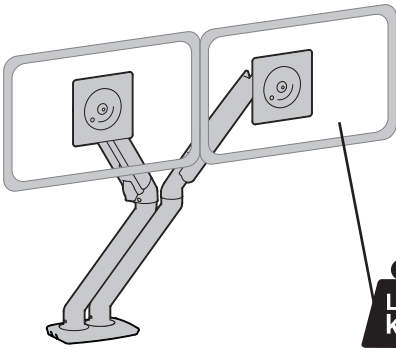

Weight Capacity per Monitor:
7 lbs (3.2 kg) - 20 lbs. (9.1 kg)

Monitor depth greater than 2.5" (64 mm) may diminish capacity.
Call Ergotron for more information.

Range of Motion

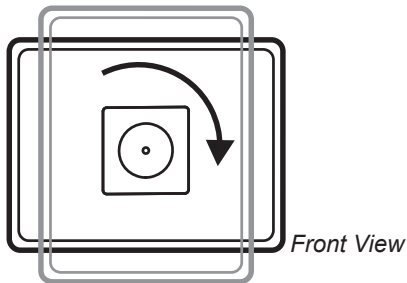
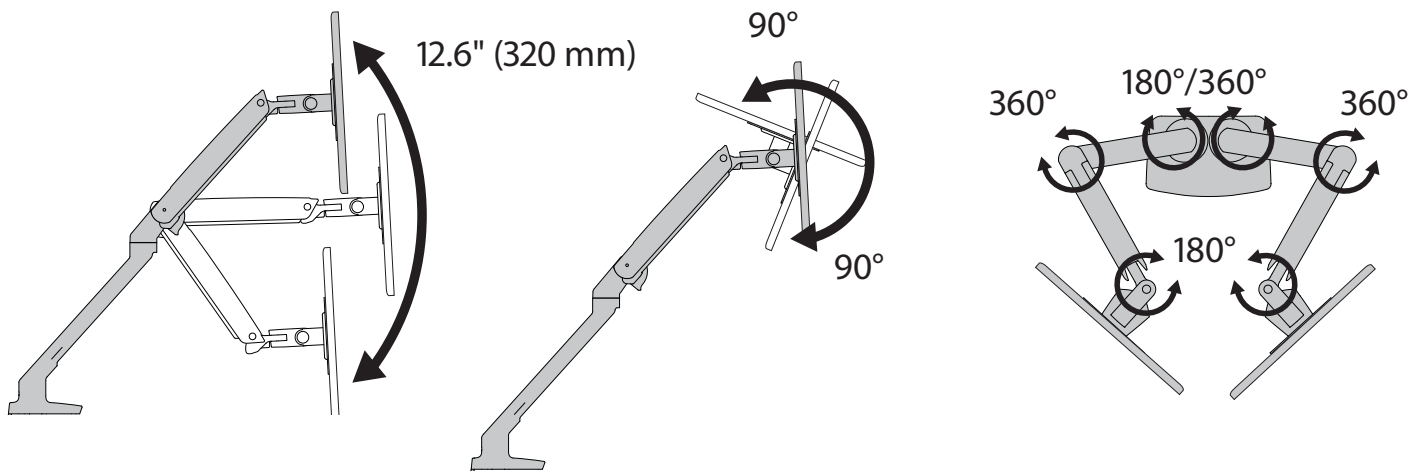

Portrait/Landscape Rotation.

© 2017 Ergotron, Inc. rev. 01/072019 DIM-MXVdual-Cclamp **Content is subject to change without notification**

Americas Sales and Corporate Headquarters

St. Paul, MN USA
(800) 888-8458
+1-651-681-7600
www.ergotron.com
sales@ergotron.com

EMEA Sales

Amersfoort, The Netherlands
+31 33 45 45 600
www.ergotron.com
info.eu@ergotron.com

APAC Sales

Tokyo, Japan
www.ergotron.com
japansupport@ergotron.com

Worldwide OEM Sales

www.ergotron.com
info.oem@ergotron.com

